

Performance of Detectors for Combined STBC-SM Systems

Xuan Nam TRAN¹, Huan Cong HO², Tadashi FUJINO² and Yoshio KARASAWA³

¹ Department of Radio-Electronics, Le Qui Don Technical University
100 Hoang Quoc Viet, Cau Giay, Vietnam, E-mail: namtx@lqdtu.edu.vn

² Department of Information and Communication Engineering

³ Advanced Wireless Communications Center

The University of Electro-Communications, Chofugaoka 1-5-1, Chofu-shi, Tokyo 182-8585

1. Introduction

Recently, there have been several proposals to combine space-time block coding (STBC) and spatial multiplexing (SM) to obtain both spatial diversity gain and spatial multiplexing gain simultaneously in a MIMO system [1], [2]. While merit of the combination is straightforwardly realized, the challenge lies in the detection method to cancel interference at the receiver. In [2] Zhao and Dubey proposed a group detection scheme, in which group detection is carried out to separate transmitted block codes, followed by the Alamouti's algorithm to decode the transmitted symbols encoded within each group. The scheme can be implemented with low complexity and relatively good bit error rate (BER) performance. However, it suffers a low limit $N \leq M$, where N and M are the number of transmit (Tx) and receive (Rx) antennas, respectively. This means that the maximum achievable multiplexing gain is limited to $M/2$. Another problem is that when zero-forcing (ZF) method is used to separate transmitted groups, matrix inversion of the channel matrix is not easily generalized for a system with large antennas.

In the recent research, we have proposed a minimum mean square error (MMSE) detection scheme for multiuser STBC systems [3], [4]. Different from the group detection scheme, our scheme uses a simple processing scheme which allows combination of interference cancellation (IC) and space-time decoding in a symbol detection manner. As a multiuser STBC system and the combined STBC-SM system are equivalent, we can apply our symbol detection scheme for multiuser STBC systems to the case of the combined STBC-SM system. We first extend the MMSE symbol detector in [3], [4] to the case of ZF and combined QR decomposition and successive interference cancellation (QR-SIC). Then we perform detailed computational complexity analysis for both the group and symbol detection schemes using ZF, MMSE and QR-SIC method. We show that our scheme allows to extend the limit on the number of Tx antennas from $N \leq M$ to $N \leq 2M$, and thus double the multiplexing gain. It is shown that all ZF, MMSE, and QR-SIC symbol detectors outperform their corresponding group detectors in terms of BER performance. In terms of complexity, while the ZF and QR-SIC symbol detectors require about 2 and 1.5 times larger complexity than their corresponding group detectors, the MMSE symbol detector allows to save up more than six times compared with the MMSE group detector.

2. Group Detection for Combined STBC-SM Systems

Consider a combined STBC-SM system as illustrated in Fig.1(a). Assume that N and M antennas are used in the transmitter and receiver, respectively. Note that since the Alamouti's STBC [5] is used N is an even number while the limitation on M will be discussed later. The channel between each pair of Tx and Rx antennas is assumed to be independent and identically distributed (i.i.d.) quasi-static. At the transmitter, a sequence of transmit symbols $\{s_k\}$, $k = 1, 2, \dots, N$, is first divided into $G = N/2$ groups. The transmit vector to be sent over 2 transmit antennas of the g th group is given by $\mathbf{s}_g = [s_{2g-1}, s_{2g}]^T$. The energy of Tx symbols is normalized such that $E_s = \text{tr}\{E\{\|s_g\|^2\}\} = 1$, where $E\{\cdot\}$ and $\text{tr}\{\cdot\}$ denote the ensemble average operation and trace of a matrix, respectively. Each pair of two consecutive symbols s_{2g-1} and s_{2g} is encoded using the Alamouti's encoding scheme [5]. Denote the complex gain of the channel from the first and second transmit antenna of the g th group to the m th receive antennas as $h_{m,2g-1}$ and $h_{m,2g}$, respectively. Under quasi-static fading assumption the $M \times 2$ MIMO channel from the g th

group of transmit antennas to the receive antennas can be expressed as $\mathbf{H}_g = [\mathbf{h}_{2g-1}, \mathbf{h}_{2g}]$ where $\mathbf{H}_g = [\mathbf{h}_{2g-1}, \mathbf{h}_{2g}]$, $\mathbf{h}_{2g-1} = [h_{1,2g-1}, h_{2,2g-1}, \dots, h_{M,2g-1}]^T$, and the superscript $(\cdot)^T$ denotes the vector/matrix transpose operation. The total channel matrix between the transmitter and receiver is defined as $\mathbf{H} = [\mathbf{H}_1, \mathbf{H}_2, \dots, \mathbf{H}_G]$. Arranging the transmit block code matrix \mathbf{S}_g as $\mathbf{S} = [\mathbf{S}_1^T, \mathbf{S}_2^T, \dots, \mathbf{S}_G^T]^T$, the receive matrix at two consecutive symbol time slots is given by $\mathbf{Y} = \sum_{g=1}^G \mathbf{H}_g \mathbf{S}_g + \mathbf{Z} = \mathbf{H}\mathbf{S} + \mathbf{Z}$, where $\mathbf{Z} \in \mathbb{C}^{M \times 2}$ is the noise matrix containing i.i.d. complex Gaussian noise samples with power spectral density N_0 .

2.1 ZF Group Detection

The ZF group detector detects a desired block code by trying to remove interference from other block codes completely. Specifically, it uses a linear combining weight matrix \mathbf{W} to make the channel matrix block diagonal as [2] $\mathbf{W}\mathbf{H} = \text{diag}\{\hat{\mathbf{H}}_1, \hat{\mathbf{H}}_2, \dots, \hat{\mathbf{H}}_G\}$, where $\hat{\mathbf{H}}_g \in \mathbb{C}^{2 \times 2}$ represents the virtual channel matrix of the corresponding block code. These virtual matrices are not unique and depends on the original channel matrix. For a 4×4 channel matrix expressed as

$$\mathbf{H} = \begin{bmatrix} \mathbf{H}_{11} & \mathbf{H}_{12} \\ \mathbf{H}_{21} & \mathbf{H}_{22} \end{bmatrix} \quad (1)$$

with $\mathbf{H}_{ij} \in \mathbb{C}^{2 \times 2}$, the received matrix \mathbf{Y} is decoupled into 2 separate groups as [2]: $\tilde{\mathbf{Y}}_{2g-1} = (\mathbf{H}_{12}^{-1}\mathbf{H}_{12} - \mathbf{H}_{22}^{-1}\mathbf{H}_{21})\mathbf{S}_{2g-1} + \tilde{\mathbf{Z}}_{2g-1}$, and $\tilde{\mathbf{Y}}_{2g} = (\mathbf{H}_{11}^{-1}\mathbf{H}_{12} - \mathbf{H}_{21}^{-1}\mathbf{H}_{22})\mathbf{S}_{2g} + \tilde{\mathbf{Z}}_{2g}$, where $\mathbf{Z}_{2g-1} \in \mathbb{C}^{2 \times 2}$ and $\mathbf{Z}_{2g} \in \mathbb{C}^{2 \times 2}$ are the resulted noise matrices.

2.2 MMSE Group Detection

Using the MMSE method the linear combining weight matrix \mathbf{W}_g used to detect the g th block code is given by the solution of the following cost function [2]

$$\mathbf{W}_g = \arg \min_{\mathbf{W}_g} \mathbb{E} \left\{ \|\mathbf{H}_g \mathbf{S}_g - \mathbf{W}_g \mathbf{Y}\|^2 \right\} = \mathbf{H}_g \mathbf{H}_g^H (\mathbf{H}\mathbf{H}^H + N_0 \mathbf{I}_M)^{-1} \quad (2)$$

where \mathbf{I}_M is an $M \times M$ identity matrix. The output corresponding to the g th group is given by [2] $\tilde{\mathbf{Y}}_g = \mathbf{W}_g \mathbf{Y} = \mathbf{H}_g \mathbf{S}_g + \tilde{\mathbf{Z}}_g$, which contains only the desired block and resulted noise.

2.3 QR-SIC Group Detection

The QR-SIC group detector decomposes the channel matrix \mathbf{H} into a unitary matrix \mathbf{Q} and an upper diagonal matrix \mathbf{R} , i.e., $\mathbf{H} = \mathbf{Q}\mathbf{R}$. Then by multiplying both sides of the system equation with \mathbf{Q} , the output corresponding to the g th group is given by $\tilde{\mathbf{Y}}_g = \mathbf{R}_{g,g} \mathbf{S}_g + \sum_{i=g+1}^G \mathbf{R}_{g,i} \mathbf{S}_i + \tilde{\mathbf{Z}}_g$, where $\mathbf{R}_{i,g} \in \mathbb{C}^{2 \times 2}$ is a sub-matrix containing elements from rows $2i - 1$ to $2i$ and from columns $2g - 1$ to $2g$ of the upper triangular matrix \mathbf{R} . The detection is performed from the G th to the first group.

Note that except the MMSE detector, both the ZF and QR-SIC group detector requires $M \geq N$. This constrain is necessary to obtain \mathbf{W} of the ZF detector and the QR decomposition of the QR-SIC detector. As a result, the multiplexing gain, is limited to $G = M/2$.

3. Symbol Detection for Combined STBC-SM Systems

The block diagram of the symbol detection scheme for combined STBC-SM systems is shown in Fig.1(b). The idea is to combine and process the receive signal in two consecutive time slots at the same time. The received vector to the space-time decoder (STD) and interference canceller (IC) is given by $\mathbf{y} = [\mathbf{y}_1^T, \mathbf{y}_2^H]^T$, where $\mathbf{y}_1 = [y_{1,1}, y_{2,1}, \dots, y_{M,1}]^T$ and $\mathbf{y}_2^* = [y_{1,2}^*, y_{2,2}^*, \dots, y_{M,2}^*]^T$ represents the receive signals at the m th receive antenna at the first and second time slots, respectively. In a similar manner we can define the noise vector as $\mathbf{z} = [\mathbf{z}_1^T, \mathbf{z}_2^H]^T$ with $\mathbf{z}_1 = [z_{1,1}, z_{2,1}, \dots, z_{M,1}]^T$ and $\mathbf{z}_2^* = [z_{1,2}^*, z_{2,2}^*, \dots, z_{M,2}^*]^T$.

Due to this processing the transmit block code reduces $\mathbf{s}_g = [s_{2g-1}, s_{2g}]^T$, and the channel matrix \mathbf{H}_g becomes

$$\mathbf{H}_g = \begin{bmatrix} \mathbf{h}_{2g-1} & \mathbf{h}_{2g} \\ \mathbf{h}_{2g}^* & -\mathbf{h}_{2g-1}^* \end{bmatrix}. \quad (3)$$

Building the total transmit signal vector and channel matrix for all $K = M$ group as $\mathbf{s} = [s_1^T, s_2^T, \dots, s_G^T]^T$, $\mathbf{H} = [\mathbf{H}_1, \mathbf{H}_2, \dots, \mathbf{H}_G]$ the signal vector model used for symbol detection is expressed as $\mathbf{y} = \mathbf{H}\mathbf{s} + \mathbf{z}$. Since the number of rows of \mathbf{H} is doubled it is possible to extend the limit on the number of transmit antennas to $N \leq 2M$. Furthermore, the increase in the size of the receive signal \mathbf{y} requires larger number of combining weights and thus better diversity gain is expected to obtain by the symbol detection scheme.

3.1 ZF Symbol Detection

Note that since the size of the channel matrix \mathbf{H} is $2M \times 2K$, the linear combining weight matrix \mathbf{W} of the ZF detector is $\mathbf{W} = \mathbf{H}^\dagger$, where † denotes the pseudo-inverse operation. The constrain on N such that ZF solution exists is thus $2G \leq 2M$ or $N \leq 2M$. The estimate of the transmitted vector \mathbf{s} is given by $\bar{\mathbf{s}} = \mathbf{Q}\{\mathbf{W}\mathbf{y}\} = \mathbf{Q}\{\mathbf{H}^\dagger\mathbf{y}\}$, where $\mathbf{Q}\{\cdot\}$ denotes the quantization function.

3.2 MMSE Symbol Detection

The solution of the linear combining matrix \mathbf{W} for the MMSE symbol detector given by

$$\mathbf{W} = \arg \min_{\mathbf{W}} \mathbb{E} \{ \|\mathbf{s} - \mathbf{W}\mathbf{y}\|^2 \} = E_s \mathbf{H}^H (E_s \mathbf{H}^H \mathbf{H} + N_0 \mathbf{I}_{2M})^{-1}. \quad (4)$$

The estimates of \mathbf{s} is then given by $\bar{\mathbf{s}} = \mathbf{Q}\{\mathbf{W}\mathbf{y}\}$.

3.3 QR-SIC Symbol Detection

Similar to the QR-SIC group detector in Sect. 2.3, the QR-SIC symbol detector relies on QR decomposition of the channel matrix $\mathbf{H} = \mathbf{Q}\mathbf{R}$ to obtain the upper triangular matrix \mathbf{R} . Then by multiplying \mathbf{Q}^T with both sides of the system equation we can obtain the estimates \hat{s}_k as $\hat{s}_k = r_{k,k} + \sum_{i=k+1}^K r_{k,i} s_i + \tilde{z}_k$, where $r_{k,i}$ is the k th row and i th element of \mathbf{R} and \tilde{z}_k is the resulted noise components due to QR decomposition. The QR-SIC detector then performs symbol detection from symbol s_K to s_1 in a SIC manner. It is also noted that the constrain on the number of transmitter antennas N is $2M \geq 2G$ or $N \leq 2M$, which allows to double the multiplexing gain over the QR-SIC group detector.

4. BER Performance and Complexity Comparison

BER Comparison: In order to obtain BER performance, simulation was performed for a 4×4 STBC-SM systems using QPSK modulation. Figure 2 compares BER performance of different detectors. It can be seen from the figure that all the ZF, MMSE, and QR-SIC symbol detectors have better BER performance compared to their corresponding group detectors. This fact implies that our proposed symbol scheme outperforms the previously proposed group detection scheme of Zhao and Dubey. It is also seen that the MMSE and QR-SIC detector have almost the same BER performance while the ZF detector suffers BER degradation due to the noise amplification problem.

Complexity Comparison: The complexity unit used in our analysis is the flop count. For simplicity, we set $N = M$. Furthermore, since the solution of the ZF group detector cannot be directly generalized for an arbitrary M , we limit our analysis for the ZF group detector to the case of a 4×4 MIMO system. In our analysis we take into account only the main sources of complexity such as computation of weight matrix, linear combining, QR decomposition and iterative detection, and the Alamouti's space-time decoding. Other minor complexity such as due to comparison, S/P conversion or complex conjugation is ignored for simplicity. Computed complexity for all the considered detectors is compared in Table 1. It can be seen that both ZF and QR-SIC symbol detector require less complexity than their corresponding group detectors. Particularly, the ZF and QR-SIC symbol detector require about 2 and 1.5 times larger complexity than their counterparts, respectively. This is clear since ZF and QR-SIC symbol detector process the receive signal using larger dimension matrices. The MMSE symbol detector, however, requires much less complexity than the MMSE group detector. As realized in the table, the MMSE symbol detector requires only about one sixth complexity of the MMSE group detector. The reason is that the covariance matrix used for computing the weight matrix \mathbf{W} of the MMSE group detector is not the same for all groups, in order to detect G groups the MMSE group detector needs to compute it for

Table 1: Complexity comparison of two detection schemes, $M = N$

	ZF	MMSE	QR-SIC
Group Detection [flops] (4×4 MIMO)	$\frac{32}{3}M^3 + 100M^2 + 4M$ (2, 298.7)	$64M^4 + \frac{856}{3}M^3 + 4M$ (34, 661)	$64M^3 + 124M^2$ (6, 080)
Symbol Detection [flops] (4×4 MIMO)	$\frac{832}{3}M^3 + 64M^2$ (5, 461.3)	$\frac{832}{3}M^3 + 64M^2 + 4M$ (5, 477.3)	$128M^3 + 112M^2$ (9, 984)

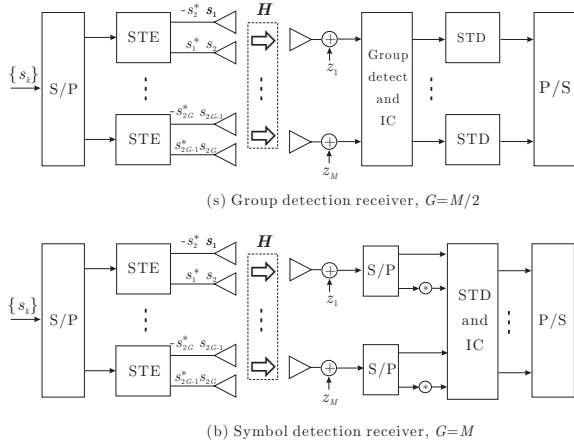

Figure 1: Configurations of detection methods for a combined STBC-SM system.

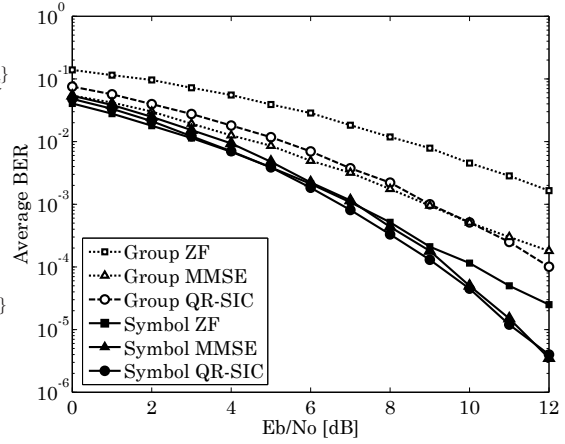

Figure 2: BER performance in a 4×4 MIMO STBC-SM system.

G times. The covariance matrix used in the MMSE symbol detector, however, is the same for all groups and thus requires its computation once only. Since most complexity of the MMSE detector belongs to that used for computing the inverse of the covariance matrix, it is clear that the MMSE group detector requires larger complexity than the MMSE symbol detector. The complexity difference between the two detectors is expected to be much larger in a STBS-SM system with large number of groups G .

From the BER and complexity comparison results we can see that the MMSE symbol detector provides the best trade-off between the BER performance and computation complexity. It is thus recommended to be used for signal detection in combined STBC-SM systems.

5. Conclusions

In this paper we have proposed symbol detection scheme for combined STBC-SM systems. We have shown that the symbol detection scheme allows to double the maximum multiplexing gain of STBC-SM systems. The proposed ZF, MMSE, and QR-SIC symbol detectors have also been shown to have better BER performance than their corresponding group detectors. Finally, we have shown that among detectors, the MMSE symbol detector is most suitable for signal detection in STBC-SM systems due to its good trade-off between BER performance and associated complexity.

References

- [1] L. Zheng and D. Tse, "Diversity and multiplexing: a fundamental tradeoff in multiple antenna channels," *IEEE Trans. on Info. Theory*, vol. 49, no. 5, pp. 1073–1096, May 2003.
- [2] L. Zhao and V. K. Dubey, "Detection schemes for space-time block code and spatial multiplexing combined system," *IEEE Comm. Letters*, vol. 9, no. 1, pp. 49–51, 2005.
- [3] X. N. Tran, T. Taniguchi, and Y. Karasawa, "Adaptive beamforming for multiuser space-time block coded systems," in *ISSSTA'04*, Sydney, Australia, September 2004, pp. 745–749.
- [4] X. N. Tran, T. Fujino, and Y. Karasawa, "An MMSE detector for multiuser space-time block coded OFDM," *IEICE Trans. on Commun.*, no. 1, pp. 141–149, 2005.
- [5] S. M. Alamouti, "A simple transmit diversity technique for wireless communications," *IEEE J. Sel. Areas in Commun.*, vol. 16, no. 8, pp. 1451–1458, 1998.