

Dual Band Ultra Low Profile Inverted L Antenna

Mituo Taguchi¹, Seiichi Sato²

^{1,2} Graduate School of Engineering, Nagasaki University

1-14 Bunkyo-machi, Nagasaki, 852-8521 Japan

¹ mtaguchi@nagasaki-u.ac.jp

² bb52111218@cc.nagasaki-u.ac.jp

1. Introduction

In recent years, due to the development of wireless communication technology, low profile, multiband or wideband antennas are desired. An “ultra low profile dipole (ULPD) antenna”, which is a horizontal dipole very closely located to a infinite conducting plane was proposed [1 - 2]. A half-wave dipole is excited at the offset points from its center. Therefore the reasonable impedance can be obtained even with a conducting plane in proximity to the dipole. The maximum gain of 8.4 dBi is obtained. The authors applied the unbalanced feed to the ultra low profile inverted L antenna on the rectangular conducting plane [3]. When the size of conducting plane is 0.245λ (λ : wavelength) by 0.49λ and the antenna height is $\lambda/30$, and the length of horizontal element is around a quarter wavelength, the input impedance of this antenna is matched to 50 ohms and its directivity becomes more than 4 dBi.

In this paper, a dual band, unbalanced fed inverted L antenna on a rectangular conducting plane is proposed and analyzed numerically. The parasitic elements are located near an unbalanced fed inverted L antenna. The design frequencies are 1.4 GHz and 2.2 GHz bands. In the numerical analysis, the electromagnetic simulator WIPL-D based on the method of moment is used [4].

2. Antenna Structure

Figure 1 shows the structure of the proposed antenna 1. The unbalanced fed inverted L antenna is mounted on the rectangular conducting plane. The antenna is composed of a semi rigid coaxial cable. The inner conductor of the coaxial cable is extended from the end of outer conductor, that is, this antenna is excited at the end of outer conductor. The distance between the vertical element of antenna and the conducting plane is $h_1 = 15$ mm. This is around $\lambda/10$ at 2 GHz. Two rectangular conducting plates are located in the same plane as the horizontal element of antenna. The distance between the parasitic plates and the conducting plane is $h_2 = 15$ mm. The other parameters of the antenna are as follows; $p_x = p_{xp} + p_{xm} = 17$ mm + 17 mm = 34 mm, $p_y = p_{yp} + p_{ym} = 65$ mm + 25 mm = 90 mm, $L_0 = 9$ mm, $L_1 = 30$ mm, $dx = 2$ mm, $p_{wx} = 5$ mm, and $p_{wy} = 80$ mm.

Figure 2 shows the structure of the proposed antenna 2. The parasitic wire is added above the antenna 1. The distance between the wire and the conducting plane is $h_3 = h_1 + 5$ mm = 20 mm. The parameters of this antenna are as follows; $p_x = p_{xp} + p_{xm} = 17$ mm + 17 mm = 34 mm, $p_y = p_{yp} + p_{ym} = 65$ mm + 25 mm = 90 mm, $h_1 = h_2 = 15$ mm, $L_0 = 7$ mm, $L_1 = 30$ mm, $dx = 2$ mm, $p_{wx} = 5$ mm, $p_{wy} = 80$ mm, and $wL = 65$ mm.

3. Results and Discussion

Figure 3 show the calculated input impedance characteristics of the proposed antenna 1. The return loss bandwidth less than -10 dB is 38 MHz at lower frequency band and 86 MHz at higher frequency band. Figure 4 show the calculated directive gain of the antenna 1 in the z direction. The maximum directive gain is 5.86 dBi at 1.46 GHz. The directive gain becomes lower at higher frequency. In order to increase the gain at higher frequency, the antenna 2 is designed. Figure 5 show the calculated input impedance characteristics of the proposed antenna 2. The return loss bandwidth less than -10 dB is 46 MHz at lower frequency band and 169 MHz at higher

frequency band. By adding the parasitic wire to the antenna 1, the return loss bandwidth at higher frequency band is extended. Figure 6 shows the calculated directive gain of the antenna 2 in the z direction. Figure 7 show the calculated electric field radiation patterns of the proposed antenna 2 at the frequency of 1.44 GHz and 2.18 GHz. The maximum directive gain becomes 6.19 dBi at 1.47 GHz and 6.38 dBi at 2.15 GHz.

4. Conclusion

The dual band, unbalanced fed inverted L antenna on a rectangular conducting plane has been proposed. Two rectangular plates and a wire are located near the inverted L antenna. The size of the antenna is 34 mm by 90 mm by 20mm. The return loss bandwidth less than -10 dB is 46 MHz at low frequency band and 169 MHz at high frequency band. The directive gain in the z direction is 6.19 dBi at 1.47 GHz and 6.38 dBi at 2.15 GHz. The measurement of the proposed antenna will be the next subject. For the application of the base station antenna of the mobile phone, the return loss bandwidth will have to be extended at the lower frequency. This will be also the next subject.

References

- [1] A. Thunvichit, T. Takano and Y. Kamata, "Ultra Low Profile Dipole Antenna with a Simplified Feeding Structure and a Parasitic Element", Trans. of IEICE, vol.89-B, no.2, pp. 576-580, 2006.
- [2] A. Thumvicit, T. Takano, Y. Kamata, "Characteristics verification of a half-wave dipole very close to a conducting plane with excellent impedance matching", IEEE Trans. on Antennas and Propagat., vol.55, no.1, pp.53-58, 2007.
- [3] T. Yamashita, M. Taguchi, "Ultra Low Profile Inverted L Antenna on a Finite Conducting Plane", Proc. of ISAP 2009, pp.361-364, 2009.
- [4] "WIPL-D Pro v7.0 3D Electromagnetic Solver Professional Edition User's Manual", WIPL-D, 2009.

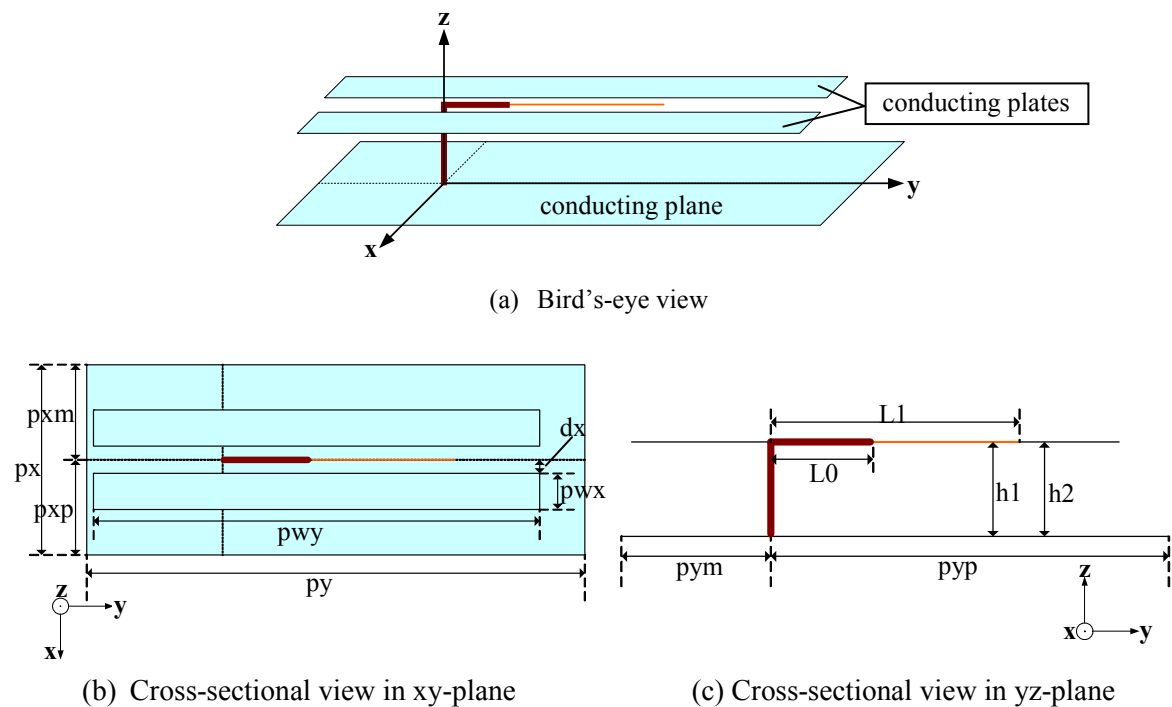
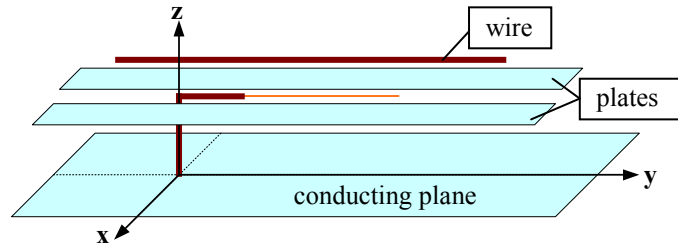

Figure 1: Proposed antenna 1.

$$px = p_{xp} + p_{xm} = 17\text{mm} + 17\text{mm} = 34\text{mm}, \quad py = p_{yp} + p_{ym} = 65\text{mm} + 25\text{mm} = 90\text{mm},$$

$$h1 = 15\text{mm}, \quad L0 = 9\text{mm}, \quad L1 = 30\text{mm}, \quad h2 = h1 = 15\text{mm}, \quad dx = 2\text{mm}, \quad p_{wx} = 5\text{mm}, \quad p_{wy} = 80\text{mm}.$$



(a) Bird's-eye view

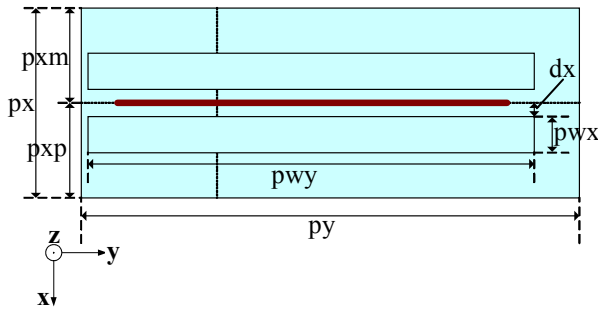

(b) Cross-sectional view in xy-plane

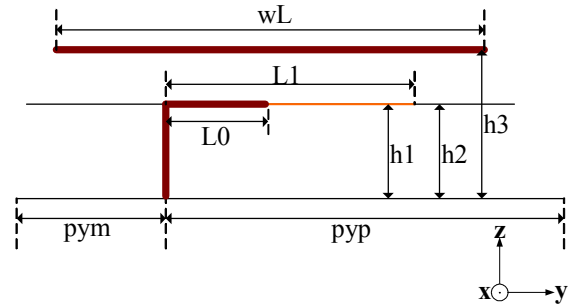

(c) Cross-sectional view in yz-plane

Figure 2: Proposed antenna 2.

$p_x = p_{xp} + p_{xm} = 17\text{mm} + 17\text{mm} = 34\text{mm}$, $p_y = p_{yp} + p_{ym} = 65\text{mm} + 25\text{mm} = 90\text{mm}$,
 $h_1 = 15\text{mm}$, $L_0 = 7\text{mm}$, $L_1 = 30\text{mm}$, $h_2 = h_1 = 15\text{mm}$, $dx = 2\text{mm}$, $p_{wx} = 5\text{mm}$, $p_{wy} = 80\text{mm}$,
 $h_3 = h_1 + 5\text{mm} = 20\text{mm}$, $wL = 65\text{mm}$

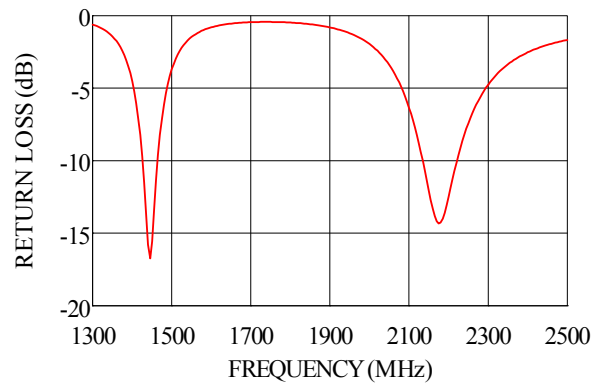
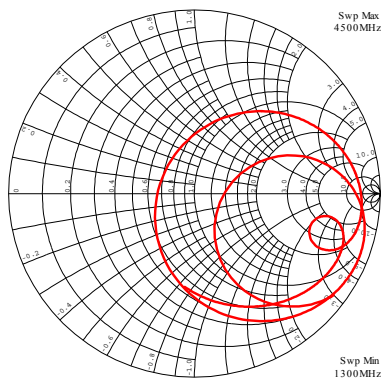

Figure 3: Calculated input impedance and return loss characteristics of proposed antenna 1.

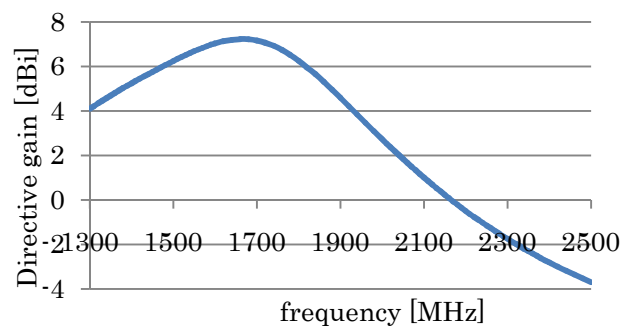

Figure 4: Calculated directive gain of the proposed antenna 1 in the z direction.

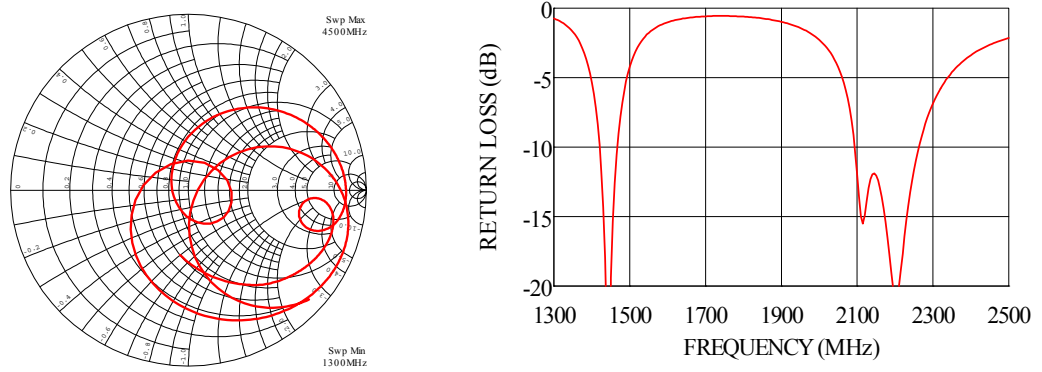

Figure 5: Calculated input impedance and return loss characteristics of proposed antenna 2.

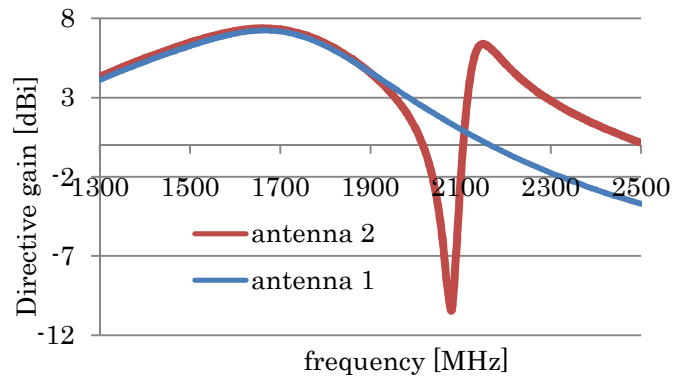
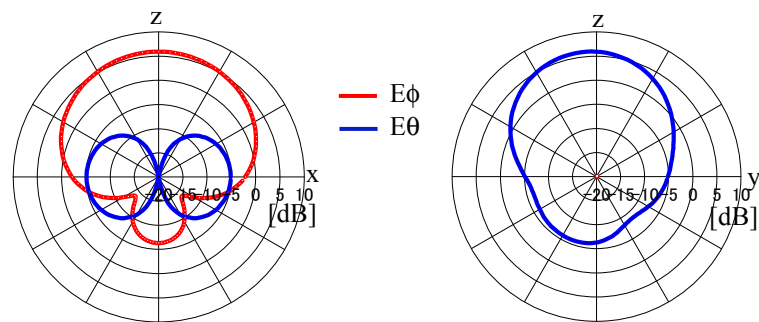

Figure 6: Directive gain of the antenna 1 and the antenna 2 in the z direction.



(a)xz-plane

(b)yz-plane

(i) 1.47 GHz

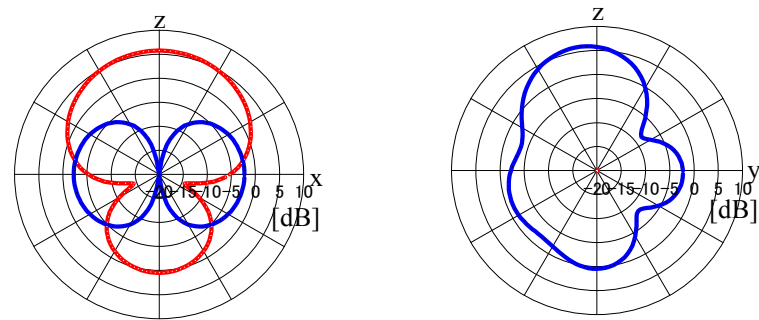

(a)xz-plane

(b)yz-plane

(ii) 2.15 GHz

Figure 7: Calculated electric field radiation patterns of the proposed antenna 2.