

# A Complexity-Reduced Active MS Antenna Selection Algorithm for Uplink Multi-user MIMO/SDM Systems

Manabu Mikami<sup>1,2</sup>, Teruya Fujii<sup>1,2</sup>

<sup>1</sup>Laboratory, Softbank Telecom Corp. / <sup>2</sup>Wireless System Research Center, Softbank Mobile Corp.  
2-38, Aomi, Koutou-ku, Tokyo, 135-8070 Japan, E-mail: manabu.mikami@tm.softbank.co.jp

## 1. Introduction

Multi-user MIMO (Multiple Input Multiple Output) systems, in which multiple Mobile Stations (MSs) equipped with single or multiple antennas communicate with a Base Station (BS) equipped with multiple antennas at the same frequency and the same timing, are attracting attention because of their potential for improving the system capacity in wireless communications [1],[2]. In order to improve the capacity of the uplink of wireless access systems, uplink multi-user MIMO systems have been proposed [2]. In uplink multi-user MIMO systems, some MSs that have better channel condition are selected and permitted to simultaneously communicate with the BS. In such systems, even if all MSs have only one transmit antenna, a MIMO channel can be realized virtually. In general, the signal transmission quality of Space Division Multiplexing based MIMO (MIMO/SDM) systems [3],[4] is degraded by co-channel interference when fewer receive antennas are used than transmit antennas. Accordingly, selecting the most suitable set of active MS antennas in order to reduce the co-channel interference is an effective technique in multi-user MIMO systems based on Space Division Multiplexing (multi-user MIMO/SDM systems) [5]. For example, the ‘‘Full search Selection Algorithm’’ (‘‘FSA’’) has been studied as an optimal active MS antenna selection algorithm [5]. Unfortunately, ‘‘FSA’’ suffers from extreme computational complexity against the number of MSs. Therefore, ‘‘Gram-Schmidt orthogonalization based Selection Algorithm’’ (‘‘GSSA’’) was proposed as a suboptimal selection technique [6]. ‘‘GSSA’’ offers a significant reduction in computational complexity with less degradation in system capacity than ‘‘FSA’’ and it is a promising approach of active MS antenna selection for multi-user MIMO/SDM systems. However, the traditional study of ‘‘GSSA’’ have investigated its system capacity (Shannon capacity) only under ideal channel conditions such as independent and identically distributed (i.i.d.) channels.

This paper evaluates the transmission performance (system capacity and Bit Error Rate) of ‘‘GSSA’’ for uplink multi-user MIMO/SDM systems under realistic propagation conditions such as spatially correlated BS antennas; the results clarify the effectiveness of ‘‘GSSA’’.

## 2. System Model

As shown in Fig. 1, we consider the uplink of a single-cell multi-user MIMO system where multiple Mobile Stations (MSs) are simultaneously communicating with a Base Station (BS) at the same frequency. The number of the BS antennas is  $N_r$ , and the number of MSs is  $N_u$ . In this paper, we make use of the standard assumption that the BS can perfectly obtain the uplink CSI matrix of each MS, we also assume that each MS is equipped with  $N_t$  antennas, with equal the transmit powers among all active MS antennas (transmit antennas) for simplicity. The BS selects some active MS antennas from among the  $N_u \cdot N_t$  ( $= N_u N_t$ ) antennas of all MSs. Note that active MS antennas selected by the BS and the BS antennas correspond to transmit antennas and receive antennas, respectively. Here we assume  $N_r \leq N_u N_t$ . Each  $N_r \times 1$  dimensional channel response vector from an MS antenna to the BS antennas is given by  $\mathbf{a}_i$  ( $i = 1, 2, \dots, N_u N_t$ ). Let  $M$  be the total number of active MS antennas. In this paper,  $M$  is set to  $N_r$  ( $= \min(N_r, N_u N_t)$ ) as an example. The received signal vector at BS antennas,  $\mathbf{x}(t)$ , is given by

$$\mathbf{x}(t) = \mathbf{H}\mathbf{s}(t) + \mathbf{n}(t) \quad (1)$$

$$\mathbf{H} = [\mathbf{h}_1 \quad \mathbf{h}_2 \quad \dots \quad \mathbf{h}_M] \quad (2)$$

where  $\mathbf{s}(t)$  denotes an  $M \times 1$  dimensional transmit signal vector,  $\mathbf{n}(t)$  denotes an  $N_r \times 1$  dimensional noise vector, the CSI matrix  $\mathbf{H}$  denotes an  $N_r \times M$  dimensional matrix, and  $\mathbf{h}_m$  ( $\mathbf{h}_m \in \{\mathbf{a}_1, \mathbf{a}_2, \dots, \mathbf{a}_{N_u N_t}\}$ ,  $m = 1, 2, \dots, M$ ) is the channel response vector of the MS antennas selected as active MS antenna set by the BS. Note that the active MS antenna selection information associated with the control signal is broadcast to MSs over the downlink. Each MS that has an active MS antenna, transmits data signal from the selected active MS antenna. The BS demultiplexes and detects the transmitted signals.

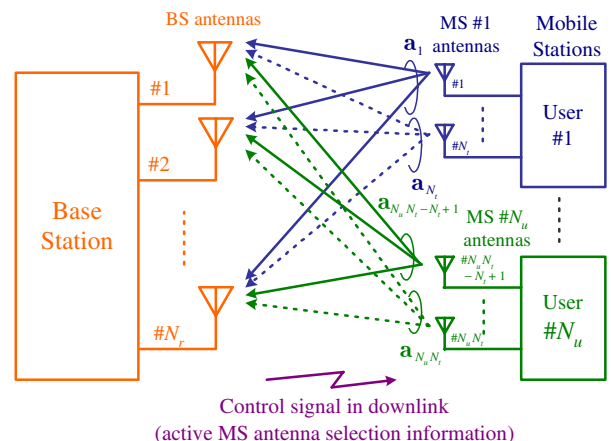

Fig. 1: System model.

### 3. Active MS Antenna Selection Algorithms

#### 3.1 Full search based Selection Algorithm (“FSA”)

The optimal active MS antenna set is defined as the combination of MS antennas that yields the largest system capacity from among all possible MS antenna set candidates. Let  $N_{all}$  be the number of all possible MS antenna candidates to select  $M$  antennas from  $N_u N_t$  antennas, the candidate index of the optimal active MS antenna set,  $k_{opt}$ , can be expressed as follows.

$$k_{opt} = \arg \max_k C_k \quad (k = 1, 2, \dots, N_{all}), \quad (3)$$

$$C_k = \log_2 \left\{ \det \left( \mathbf{I} + \frac{P_s}{P_n} \mathbf{H}_k^H \mathbf{H}_k \right) \right\} = \arg \max_k \left\{ \log_2 \prod_{m=1}^M \left( 1 + \frac{P_s}{P_n} \lambda_m^{[k]} \right) \right\}, \quad (4)$$

$$\mathbf{H}_k = [\mathbf{h}_1^{[k]} \quad \mathbf{h}_2^{[k]} \quad \dots \quad \mathbf{h}_M^{[k]}], \quad (5)$$

where  $C_k$  denotes the system capacity in the uplink of a multi-user MIMO/SDM systems for the  $k$ -th possible MS antenna set [5].  $\mathbf{I}$ ,  $\det(\cdot)$ , and  $(\cdot)^H$  denote an identity matrix, the determinant of the matrix and the complex conjugate transpose, respectively.  $P_s$  and  $P_n$  denote the transmit power of each transmit antenna and the thermal noise power of each receive antenna, respectively.  $\mathbf{H}_k$  is an  $N_r \times M$  dimensional matrix whose columns  $\mathbf{h}_m^{[k]}$  are comprised of the channel response vectors of each MS antenna for the  $k$ -th possible MS antenna set, and  $\lambda_m^{[k]}$  denotes the  $m$ -th eigenvalue of  $\mathbf{H}_k^H \mathbf{H}_k$ . When the optimal active MS antenna set is selected, the CSI matrix  $\mathbf{H}$  is given by  $\mathbf{H} = \mathbf{H}_{k_{opt}}$ .

The optimal active MS antenna set,  $k_{opt}$ , can be found by exhaustive search. Accordingly, the BS has to calculate the system capacities for all possible MS antenna set candidates in order to identify the optimal active MS antenna set [5]. In this paper, this optimal active MS antenna set selection algorithm based on exhaustive search is called the “Full search based Selection Algorithm” (Hereafter, “FSA”). “FSA” guarantees to find the true optimal active MS antenna set. However, the number of all possible MS antenna set candidates,  $N_{all}$  in eq.(3), is given by

$$N_{all} = \binom{N_u N_t}{M} = \frac{(N_u N_t)!}{M! (N_u N_t - M)!} = \frac{1}{M!} \prod_{m=0}^{M-1} (N_u N_t - m) \approx \frac{1}{M!} O((N_u N_t)^M) \quad (N_u \rightarrow \infty). \quad (6)$$

The above equation means that the computational complexity of “FSA” explodes with the number of MSs. For example, when  $N_r$ ,  $N_t$ , and  $M$  are all 4,  $N_{all}$  is 35,960 in the case of  $N_u = 8$ , and 635,376 in the case of  $N_u = 16$ . Therefore, though “FSA” is an optimal active MS antenna selection algorithm, it is impractical to implement when the number of MSs is large.

#### 3.2 Gram-Schmidt orthogonalization based Selection Algorithm (“GSSA”)

Due to the excessive complexity of “FSA”, a suboptimal active MS antenna selection algorithm was proposed [6]. Here, we describe the basic principle of the suboptimal algorithm.

Applying QR decomposition to  $\mathbf{H}_k$ ,  $\mathbf{H}_k$  is represented as  $\mathbf{H}_k = \mathbf{Q}_k \mathbf{R}_k$  [7], where  $\mathbf{Q}_k$  is an  $N_r \times M$  dimensional matrix satisfying  $\mathbf{Q}_k^H \mathbf{Q}_k = \mathbf{I}$ , and  $\mathbf{R}_k$  is an  $M \times M$  dimensional upper triangular matrix with  $r_{m,m}^{[k]}$ ,  $m \geq n$  denoting its non-zero elements and its diagonal elements  $r_{m,m}^{[k]}$  as real numbers. Assuming  $N_r \geq M$ , we can obtain the following equation.

$$\det(\mathbf{H}_k^H \mathbf{H}_k) = \det(\mathbf{R}_k^H \mathbf{Q}_k^H \mathbf{Q}_k \mathbf{R}_k) = \det(\mathbf{R}_k^H \mathbf{R}_k) = \left| \prod_{m=1}^M r_{m,m}^{[k]} \right|^2 = \left( \prod_{m=1}^M |r_{m,m}^{[k]}| \right)^2 \quad (7)$$

where  $|\cdot|$  denotes the absolute value, and the triangular matrix. Assuming  $P_s \lambda_m^{[k]} / P_n \gg 1$  in eq.(4) and applying eq.(7) to eq.(4),  $k_{opt}$  is approximated by

$$k_{opt} \cong \arg \max_k \left\{ \log_2 \prod_{m=1}^M \left( \frac{P_s}{P_n} \lambda_m^{[k]} \right) \right\} = \arg \max_k \left( \prod_{m=1}^M \lambda_m^{[k]} \right) = \arg \max_k \left\{ \det(\mathbf{H}_k^H \mathbf{H}_k) \right\} = \arg \max_k \left( \prod_{m=1}^M |r_{m,m}^{[k]}| \right)^2 \quad (8)$$

Equation (8) means that the highest system capacity can be obtained if the transmit antennas are selected so as to enlarge each diagonal element of  $\mathbf{R}_k$ ,  $|r_{m,m}^{[k]}|$ . It is known that one of suboptimal active MS antenna selection algorithms can be realized based on this principle [6]. In order to find the MS antennas with larger  $|r_{m,m}^{[k]}|$  in eq.(8) with less complexity, the suboptimal algorithm applies Gram-Schmidt orthogonalization [7]. This algorithm is comprised of as many steps as the total number of active MS antennas,  $M$ , calculates each  $|r_{m,m}^{[k]}|$  using Gram-Schmidt orthogonalization, and successively selects each MS antenna with the highest orthogonal component from the channel response vectors of the antennas selected in the previous steps so as to enlarge each  $|r_{m,m}^{[k]}|$ . In this paper, this algorithm is called “Gram-Schmidt orthogonalization based Selection Algorithm” (“GSSA”). We describe “GSSA” in detail as follows.

In the first step, it selects the MS antenna with the largest norms of channel response vectors,  $\|\mathbf{a}_i\|$  ( $i = 1, 2, \dots, N_u N_t$ ), for the first active MS antenna. The index of the first active MS antenna,  $i_1$ , satisfies the following equation.

$$i_1 = \arg \max_i (\|\mathbf{a}_i\|) \quad (9)$$

In the  $m$ -th step, ‘‘GSSA’’ calculates the orthogonal components of the channel response vectors against that of the  $m - 1$  active MS antennas selected in the previous  $m - 1$  steps with the use of Gram-Schmidt orthogonalization, and selects the  $m$ -th active MS antenna with the largest amplitude of the orthogonal component. The index of the  $m$ -th active MS antenna,  $i_m$ , satisfies the following equation.

$$i_m = \arg \max_{i \notin \{i_1, \dots, i_{m-1}\}} (\|r_{m,m}^{(i)}\|) \quad (10)$$

Here, each  $r_{m,m}^{(i)}$  ( $i \notin \{i_1, i_2, \dots, i_{m-1}\}$ ) can be obtained by the following Gram-Schmidt orthogonalization.

$$r_{m,m}^{(i)} = \|\mathbf{v}_m^{(i)}\|, \quad \mathbf{v}_m^{(i)} = \mathbf{a}_i - \sum_{j=1}^{m-1} r_{j,m}^{(i)} \mathbf{q}_j, \quad r_{j,m}^{(i)} = \mathbf{q}_j^H \mathbf{a}_i, \quad \mathbf{q}_j = \mathbf{q}_j^{(i_j)}, \quad \mathbf{q}_j^{(i)} = \frac{1}{r_{j,j}^{(i)}} \mathbf{v}_j^{(i)}, \quad (j = 1, \dots, m) \quad (11)$$

The channel response vector of the antenna selected in the  $m$ -th step,  $\mathbf{a}_{i_m}$ , is set to  $\mathbf{h}_m$  as  $\mathbf{h}_m = \mathbf{a}_{i_m}$ . Meanwhile, the number of the examinations needed to solve  $i_m$  and  $\mathbf{h}_m$  in the  $m$ -th step,  $N_{GSSA}^{(m)}$ , is  $N_u N_t - (m - 1)$ .

The process is repeated up to the  $M$ -th step. Finally,  $M$  MS-antennas are selected as the active MS antennas, and the CSI matrix in eq.(2),  $\mathbf{H}$ , is generated. In ‘‘GSSA’’, the number of candidates examined to select the active MS antenna set,  $N_{GSSA}$ , is roughly given by

$$N_{GSSA} = \sum_{m=1}^M N_{GSSA}^{(m)} = \sum_{m=1}^M \{N_u N_t - (m - 1)\} = M N_u N_t - \frac{1}{2} M (M - 1). \quad (12)$$

Compared to eq. (6) and (12), it is found that ‘‘GSSA’’ has drastically lower computational complexity than ‘‘FSA’’ when the number of MSs,  $N_u$ , is large. Since ‘‘GSSA’’ is a suboptimal algorithm and cannot guarantee to find the true optimal active MS antenna set, it is important to evaluate its transmission performance.

## 4. Simulation Conditions

We evaluate the performance of a multi-user MIMO/SDM system employing ‘‘GSSA’’ by computer simulation. The simulation conditions are as follows.

Table 1 shows the simulation parameters. Each MS has 4 antennas ( $N_t = 4$ ), and BS has 4 antennas ( $N_r = 4$ ). The number of MSs is  $N_u$ . For simplicity, BS limited the total number of streams,  $M = \min(N_r, N_u N_t) = 4$ , and selected  $M$  transmit antennas from all MSs. We assumed that all user channels were mutually independent quasi-static Rayleigh flat fading channels. In this paper, the spatial correlation between BS antennas is given by the arrival angle distribution of signals. Here, the arrival angle of signals from each MS is assumed to follow a Laplace distribution with parameters of the direction of the MS,  $\theta$ , and the variance  $\sigma_r^2$ . Each MS with an active MS antenna transmitted 16QAM modulated data from the active transmit antennas. We assumed that the transmit signal power per stream, the average received SNR (Signal-to-Noise-power-Ratio) were the same for all streams in order to simplify the performance evaluation. We also assumed that the transmit timing of each active MS was perfectly controlled and that the MIMO receivers could perfectly estimate the CSI matrix. The BS used by the MMSE-based QRM-MLD algorithm [8],[9] to detect the signals transmitted from the selected active MS antennas. The MMSE-based QRM-MLD algorithm, which uses QR decomposition of the MIMO channel matrix combined with M-algorithm, can achieve almost the same performance as the original Maximum Likelihood Detection (MLD) algorithm [3]. In each decoding step of the MMSE based QRM-MLD, the number of surviving symbol replica candidates,  $S_n$ , ( $n = 1, 2, \dots, M - 1$ ), was set to 8 ( $S_1 = S_2 = \dots = S_{M-1} = 8$ ).

## 5. Performance Evaluation

Fig.2 and Fig.3 show the cumulative probability of the system capacity and the BER characteristics, respectively. In these figures, the solid lines show the with ‘‘GSSA’’ condition and the dashed lines show the with ‘‘FSA’’ condition; as the parameter is the angular spread at the BS antennas,  $\sigma_r$ .

In Fig.2 the average received SNR is set to 20 [dB]. From Fig.2, the penalty at the cumulative probability of  $10^{-2}$  for both  $\sigma_r = 5$  [deg.] and  $\sigma_r = 10$  [deg.] is only about 0.1, 0.2, 0.2 [bits/s/Hz] for  $N_u$  of 2, 4, and 8, respectively.

Table 1: Simulation conditions

Number of antennas	MS : $N_t = 4$ [antennas/user], BS : $N_r = 4$ [antennas]
Number of users (MSs)	$N_u = 2 \sim 8$
Total number of streams	$M = \min(N_r, N_u N_t) = 4$ (fixed)
Modulation	16QAM
Antenna element arrangement	Uniform circular array
Antenna element separation	MS : $\lambda/2$ , BS: $5\lambda$
Fading model	Quasi-static flat Rayleigh fading (uncorrelated fading among each user)
Angle of MS $\theta$	Uniformed distribution: $0^\circ \sim 360^\circ$
Angle distribution of multi-paths	MS: Uniformed distribution BS: Laplace distribution ( $\theta$ , $\sigma_r^2$ )
Average received SNR	Equal level among each stream
Synchronization among users	Perfect synchronization
Channel estimation	Ideal
MIMO signal detection algorithm	MMSE based QRM-MLD (Number of surviving symbol replica candidates in each decoding step, $S_n = 8$ )

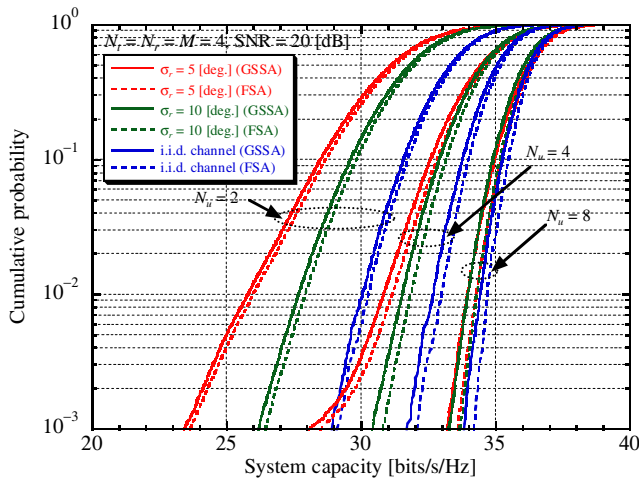

Fig.2: Cumulative probability of system capacity.

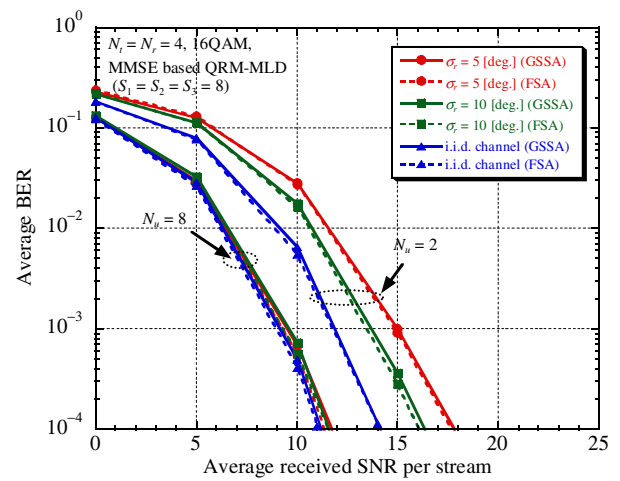

Fig.3: BER characteristics

From these results, it is found that the system capacity penalty of “GSSA” from “FSA” is very small and that it is almost independent of the spatial correlation between BS antennas.

In Fig.3, we evaluate the required average received SNR that yields the average BER of  $10^{-3}$ . From Fig. 3, we find that the BER characteristic degradation of “GSSA” from “FSA” is very small. Compared to “FSA”, “GSSA” degrades the required average SNR for  $\sigma_r = 5$  [deg.] by only about 0.1 dB and 0.2 dB for  $N_u$  of 2 and 8, respectively and while the degradation for  $\sigma_r = 10$  [deg.] is only 0.2 dB and 0.2 dB for  $N_u$  of 2 and 8, respectively. These results show that “GSSA” can achieve almost the same BER characteristics as “FSA” and that the BER characteristic degradation of “GSSA” hardly depends on the spatial correlation between the BS antennas.

## 6. Conclusions

This paper evaluated the transmission performance of uplink multi-user MIMO/SDM systems under spatial correlated channels and the use of “Gram-Schmidt orthogonalization based Selection Algorithm (GSSA)”. Simulation results show that the transmission performance of “GSSA” is almost independent of the spatial correlation between BS antennas and that its performance degradation from the optimal MS antenna selection algorithm is very small. These results clarify that “GSSA” is an efficient suboptimal active MS antenna selection for uplink multi-user MIMO/SDM systems.

## Acknowledgments

A portion of this work was sponsored by the Strategic Information and Communications R&D Promotion Program (SCOPE) of the Ministry of Internal Affairs and Communications of Japan.

## References

- [1] N. Geng, and I. Viering, and M. Kiessling, “Multi-user MIMO-OFDM cell throughput under real-world propagation conditions,” Proc. IEEE VTC2002-Fall, vol.2, pp.873–883, Vancouver, Canada, Sept. 2002.
- [2] Y. Takatori, R. Kudo, A. Ohta, K. Ishihara, K. Nishimori, and T. Kubota, “Robust beamforming method for frequency offsets in uplink multiuser OFDM-MIMO,” Proc. ISAP2006, Orchard Hotel, Singapore, Nov. 2006.
- [3] A. V. Zelst, R. V. Nee, and G. A. Awater, “Space division multiplexing (SDM) for OFDM systems,” Proc. IEEE VTC2000-Spring, vol.2, pp.1070–1074, Tokyo, Japan, May 2000.
- [4] R. W. Heath, Jr., S. Sandhu, and A. Paulraj, “Antenna selection for spatial multiplexing systems with linear receivers,” IEEE Commun. Lett. vol.5, no.4, pp.2276–2280, Apr. 2001.
- [5] J. Ohkawara, T. Nishimura, T. Ohgane, and Y. Ogawa, “A study on transmit-antenna selection for multi-user MIMO uplink,” IEICE Technical Report, RCS2005-135, Jan. 2006.
- [6] T. Yoo and A. Goldsmith, “On the optimality of multiantenna broadcast scheduling using zero-forcing beamforming,” IEEE J. Select. Areas Commun., vol.24, no.3, pp.528–541, March 2006.
- [7] G. Strang, *Linear algebra and its applications*, 3rd Ed., Academic Press, New York, 1988.
- [8] M. Mikami and T. Fujii, “A study on MMSE extended QRM-MLD algorithm for single-user/multi-user MIMO transmission systems,” IEICE Technical Report, RCS2005-190, March 2006.
- [9] S. Sun, D. Yongmei, L. Zhongding, K. Higuchi, and H. Kawai, “Pseudo-inverse MMSE based QRD-M algorithm for MIMO-OFDM,” Proc. IEEE VTC2006-Spring, vol.3, pp.1545–1549, Melbourne, Australia, May 2006.