

Systems Requirements for NASA Deep Space Network Microwave Antenna Holography

D. J. Rochblatt

Jet Propulsion Laboratory, California Institute of Technology
Pasadena, California 91109

I. Introduction

This report considers instrumentation systems for NASA Deep Space Network (DSN) microwave antenna holography. Functional requirements, performance, and future technological growth potential are considered, leading to a complete DSN capability for operational "health check," evaluation, diagnostics, performance optimization, and a flexible R&D tool for further development of the large antennas.

A microwave antenna holography implementation for the DSN must satisfy at least three primary requirements. First, it must satisfy DSN operational needs for a quick "health check" of the antenna mechanical and microwave subsystems to yield an unambiguous go/no-go operational status result. The holography measurement must be conducted within the DSN frequency bands using the operational microwave front-end equipment. To derive the required data, holographic maps of low resolution and medium accuracy are sufficient. The measurement time needed for these maps is about 30 minutes, and the measurements will be carried out by antenna operators.

Second, the system must satisfy DSN initiation and maintenance needs for data used for reflector panel setting adjustments. To derive the required data, holographic maps of high resolution and high precision are needed. 12 hours/6 hours for the 70m/34m antennas, respectively, are needed to complete the data acquisition measurements for these maps. The holography system chosen should promise future reduction in measurement time as stronger signal sources become available. This panel setting mode is not expected to be used frequently. Therefore, a special test equipment mode of operation by a station analyst could be used. The data processing and detailed diagnostics of the data need not be the station personnel's responsibility and might be done by design and implementation personnel at the Jet Propulsion Laboratory.

Third, a DSN microwave holography system must provide future technological growth potential in terms of measurement precision, data acquisition speed, and providing capabilities for understanding the performance limitations of large microwave reflector antennas for deep space communications. The measurement system selected must support the DSN's need to acquire every 0.1-dB gain improvement available from its major antennas. Microwave holography can provide a major tool in future studies of

understanding thermal, wind, reflector panel manufacturing and setting precision, beam pointing, focus, gain and phase stabilities, mechanical hysteresis, weather, paint, aging, and other factors.

Additionally, the operational measurement system must be compatible with the antenna operational configurations. Both conventional and beamwaveguide 32-GHz capable antennas must be supported. The use of non-DSN frequencies, feeds, or amplifiers/receivers should be minimized or eliminated if possible. Commercial equipment capable of manufacturer support for a 10-year period must be carefully selected.

II. Requirements Summary

The parameters critical for the quality of the images derived from holographic measurements are signal-to-noise ratio (SNR), instrumentation dynamic range, and overall measurement system accuracy. A detailed mathematical derivation of the related equations can be found in Refs. 1, 2, and 3. Figure 1 is a conceptual block diagram of a holographic measurement system. Figure 2 is a computer simulation of effects of front end and receiver noise on holographic data processing. The test antenna beam peak SNR is 73 dB and the reference antenna SNR is 40 dB. The resulting image profile error has a standard deviation (1σ) of 0.07 mm.

The "health check" mode of operation requires a lateral resolution of typically $D/20$, which can be achieved with a data array size of 25×25 . The standard deviation of the image error profile need be no better than $\lambda/100$, and optimum subreflector settings need be no better than $\lambda/10$ at 8 GHz. When the antenna scan rate traverses a sidelobe per second and allows sample smearing of 5 to 10 percent, an integration time of 0.1 sec is indicated. A measurement time under the above conditions will take 30 min. To achieve image quality with standard deviation of 0.5 mm on the 70m or 34m antennas with lateral resolutions of $D/20$, an approximate beam peak SNR of 45 dB (0.1-sec integration period) is required at X-band (8.4 GHz), or 42 dB at Ku-band (11.45 GHz). To achieve the same specifications with phase retrieval holography, an approximate beam peak SNR of 60 dB is required at S-band (2.2 GHz).

In the panel setting mode, the large number of individual panels on the 70m and 34m antennas (arranged in 17 and 9 circumferential rings, respectively) with a panel area of 2 meter² dictates the need for high lateral resolution to about 0.35m. Array data sizes of 197×197 and 127×127 for the 70m and 34m antennas, respectively, are necessary. For a maximum of 0.1-dB degradation in antenna efficiency due to random surface imperfections, the rms surface error must be no greater than 0.012λ . This translates to an rms surface of 0.43 mm at X-band (8.4 GHz) and 0.11 mm at Ka-band (32 GHz). To achieve surface error maps with one standard deviation of 0.1 mm at resolution cell size of 0.35m for the 70m antenna, a beam peak SNR of 73 dB is

required at Ku-band (11.45 GHz) and 75 dB at X-band (8.4 GHz). With 25 data points on the average on each panel, this provides screw adjustment accuracy of 0.02 mm. Theoretically, one calculates that 87 dB SNR would be required at S-band (2.2 GHz). However, diffraction effects at this frequency contaminate the holographic images, making that data unsuitable for precise panel setting. To achieve the same accuracy on the 34m antenna, a beam peak SNR of 66 dB is required at Ku-band and 69 dB at X-band (Ref. 3). The accuracy of the subreflector position correction will typically be 0.5 mm.

The accuracy across holographic maps varies with the aperture amplitude taper illumination. Results are better at the center of the dish and gradually become worse toward the edge of the dish. For a uniformly illuminated dish, accuracy stays relatively constant through most of the dish and becomes quickly worse just at the edge where the illumination falls off rapidly.

Antenna scan rates, signal SNR, signal source orbit stability, integration time, and sample smearing constraints lead to 12 hours (presently nighttime) measurement time for the 70m antenna and 6 hours for the 34m antenna to obtain the high-resolution high-precision maps. A decrease in measurement time is desirable and can only be achieved with a receiver system compatible with the signal source. Such a system will provide higher SNR at shorter integration time periods as stronger signal sources become available. The narrow-bandwidth system matched to satellite CW signals can provide this future capability. This will allow low-resolution (25 x 25) image data acquisition in approximately 15 minutes. Meaningful wind and thermal information, for example, would become available for the first time with such fast imaging capture. Additional system requirements include antenna pointing precision of ± 0.002 deg and angle encoders sampling intervals of 10 msec.

References

1. Scott, P. F. and Ryle, M., "A Rapid Method for Measuring the Figure of a Radio Telescope Reflector," *Mon. Not. Roy. Astr. Soc.*, 178, pp. 539-545, 1977.
2. D'Addario, L. R., "Holographic Antenna Measurements," Memo No. 202 NRAO, Charlottesville, Virginia, pp. 1-20, November 1982.
3. Rochblatt, D. J. and Seidel, B. L., "DSN Microwave Antenna Holography," *JPL TDA Progress Report 42-76*, pp. 27-42, 1983.

Acknowledgment

The research described in this paper was carried out at the Jet Propulsion Laboratory, California Institute of Technology, under a contract with the National Aeronautics and Space Administration.

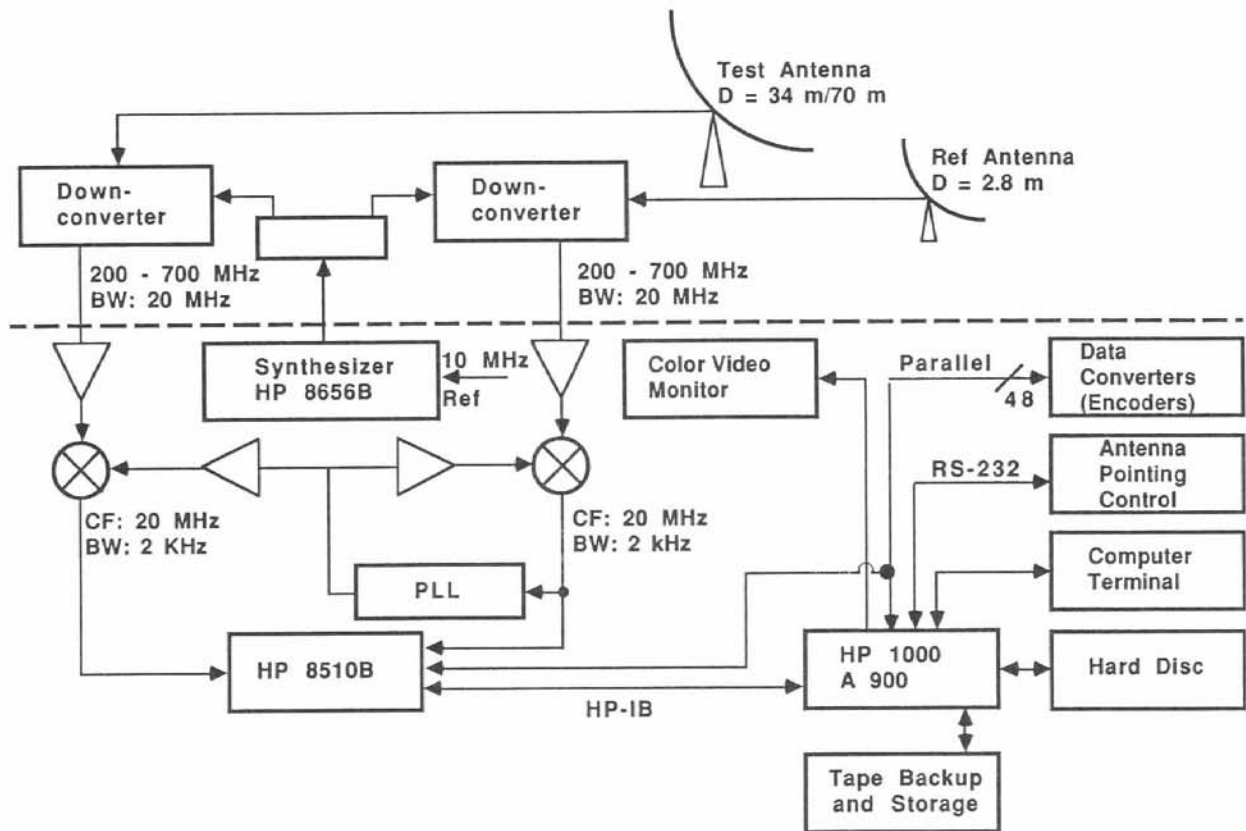

Figure 1. Block diagram of a holographic measurement system.

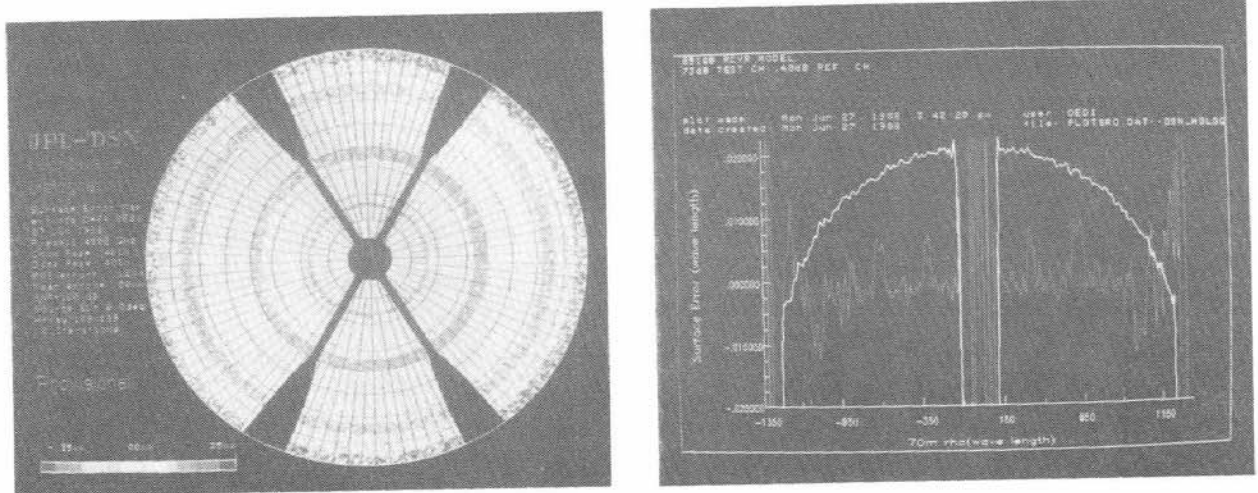

Figure 2. Computer simulation of effect of front end and receiver noise on holographic data processing. Test antenna beam peak SNR is 73 dB and reference antenna SNR is 40 dB. The resulting image profile error has a standard deviation (1σ) of 0.07 mm.