

Radiation Characteristics of Rotationally Symmetric Current Planar Antenna with Unbalanced Feed

Hiromichi SUZUKI[†], Satoshi MIZOGUCHI[†], Takashi AMANO[†], and Tasuku MOROOKA^{††}

[†]Core Technology Center, Toshiba Corp.
2-9, Suehiro-Cho, Ome, Tokyo 198-8710, Japan

^{††}Toshiba Research Consulting Corporation
1, Komukai, Toshiba-cho, Saiwai-ku, Kawasaki, 212-8582, Japan
E-mail:hiromichi4.suzuki@toshiba.co.jp

I. INTRODUCTION

It is common to mount a monopole type retractable antenna for mobile handsets. However, built-in type low profile antennas are preferable because of design flexibility [1][2][3]. Moreover, a monopole type antenna has omni directional radiation pattern that decreases radiation efficiency considerably in talk position. To improve antenna performance in talk position, we proposed a new planar antenna which has rotationally symmetric current to suppress radiation toward an operator side [4][5][6]. The antenna reduces current on the PCB-GND by using balanced feed like a dipole has. Therefore the antenna has less change of impedance in opening-and-closing state of flip of a mobile handset. Comparing with free space condition, a mobile handset with the built-in type antenna with hand also gives smaller change of impedance than a monopole antenna does. Looking from an operator side, rotational symmetry of current distribution makes a null toward an operator side and results in higher radiation efficiency in talk position. However, adding a chip balun to the antenna increases both insertion loss and total antenna cost. This paper proposes a method to improve the antenna performance when the chip balun is eliminated and the antenna is forced to operate under unbalanced feeding condition.

II. DESIGN CONCEPT

Figure 1 shows the configuration of H-shaped dipole with unbalanced feed. H-shaped dipole is an example of planer structure antennas with rotationally symmetric current flow. To make unbalanced feed of H-shaped dipole, balanced feeding lines connected to a chip balun are cut. After removing a chip balun, one line is shorted to the PCB-GND and another line is connected to a feeding line of an unbalanced amplifier. Simulation analysis is done by MoM with plate segmentation. The test frequency is 2GHz. Figure 2 shows radiation patterns on xy-plane and their current distribution. Figure 2 (a) and (b) are only different in feeding structure. In Figure 2-(b), the radiation pattern is unsymmetrical because each of vertical conductors has different current strength. To get equal current strength in each conductor, vertical element length L_{dp} and loop length L_{lp} shown in Figure 3 are varied and investigated.

III. RESULTS OF CALCULATION AND MEASUREMENT

Figure 4 shows radiation patterns on horizontal plane at resonant frequency. In the case of

$L_{lp}=0.69\lambda$ in Figure 4-(1), the radiation pattern is changed to lose suppression toward an operator side. But in the case of $L_{lp}=1.01\lambda$ in Figure 4-(2), the radiation pattern gets better than Figure 4-(1). When L_{lp} reaches 2.19λ , the most preferable pattern is obtained under unbalanced feed. Radiation characteristics are measured using the PCB-GND with the antenna shown in Figure.1. The radiation patterns are simulated and shown in Figure 5, where the measured patterns are also shown. Both simulation and measured radiation patterns have similar characteristics. To confirm above results, measurements that change loop length L_{lp} as a parameter are done below and shown in Figure 6. Differences of radiation intensity are shown. Figure 6-(a) shows difference of E_{θ} strength in right and left direction by changing loop length L_{lp} . Figure 6-(b) shows difference of E_{θ} strength and E_{ϕ} strength toward operator direction. When L_{lp} exceeds 1.0λ , symmetry of radiation pattern improves because differences in right and left direction reduce to 2dB or less. The improvement of radiation symmetry presumably depends on resonance of the loop structure. The loop length L_{lp} in H-shaped dipole is close to 1.0λ . Additionally, the ratio between co- and cross- polarization exceeds 17 dB or more and large suppression toward an operator side is promised. Both simulated and measured results are agreed well.

IV. CONCLUSIONS

In this paper a method to improve radiation patterns is proposed. It is founded that using a H-shaped dipole with unbalanced feed, radiation symmetry and radiation suppression toward an operator side can be improved by changing the loop length. And above characteristics are confirmed by both simulation and measurements. By this proposed method, a chip balun is able to be removed.

REFERENCES

- [1] T. Taga and K. Tsunekawa, "Performance Analysis of a Built-in Planar Inverted F Antenna for 800 MHz Band Portable Radio Units", IEEE J.Sel.Areas Commun., SAC-5-5, 921, 1987.
- [2] T. Amano, N. Chiba and Iwasaki, "A Quarter-Wavelength Shorted Microstrip Antenna with a Slot for Dual-Frequency Operation" IEICE trans. Electron., vol.E82-C, no.7, pp.1211-1216, July 1999.
- [3]Y. Kim, H. Morishita, Y. Koyanagi and K. Fujimoto, "A folded loop antenna system for handsets design developed and based on the advanced design concept", IEICE Trans. Common., vol.E84-B, no.9, pp.2468-2475, Sept. 2001.
- [4]S. Mizoguchi, T. Amano, K. Kawabata, T. Morooka, "Radiation Characteristics of rotationally symmetric current planar antenna", Proc. 2003 IEICE general conf., IEICE Japan, B-1-203, March 2003.(in Japanese)
- [5]S. Mizoguchi, T. Amano, H. Suzuki, T. Morooka, "Broadband Characteristics of rotationally symmetric current planar antenna" ,Proc. 2003 IEICE society conf., IEICE Japan, B-1-204, September 2003. (in Japanese)
- [6]S. Mizoguchi, T. Amano, H. Suzuki, T. Morooka, "A Novel Rotationally Symmetric Current Planar Antenna" , APMC'03, WA4-2, November 2003.

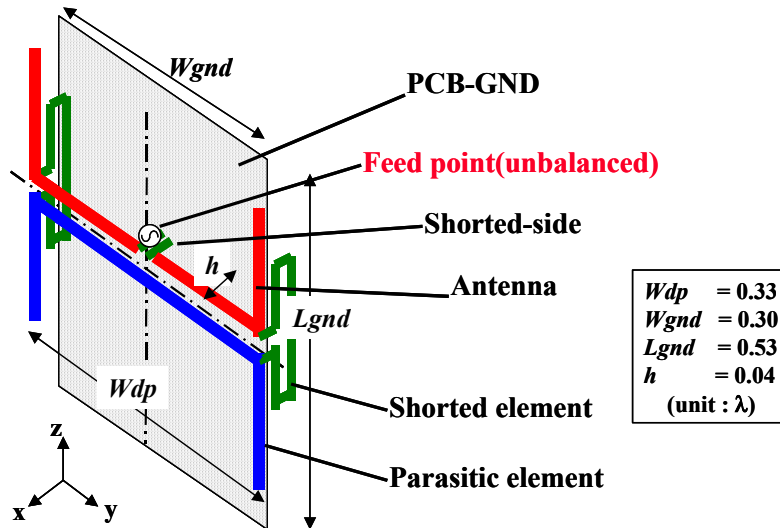

Fig.1 H-shaped dipole antenna (unbalanced)

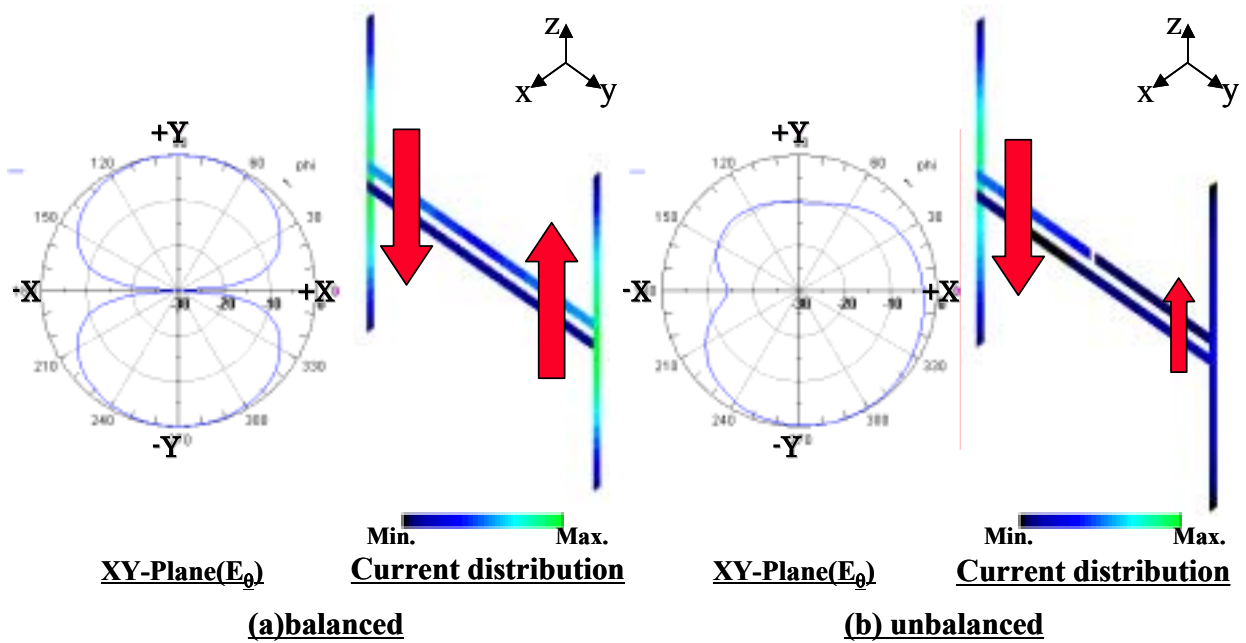

Fig.2 radiation pattern on XY-plane and current distributions ((a) balanced, (b) unbalanced)

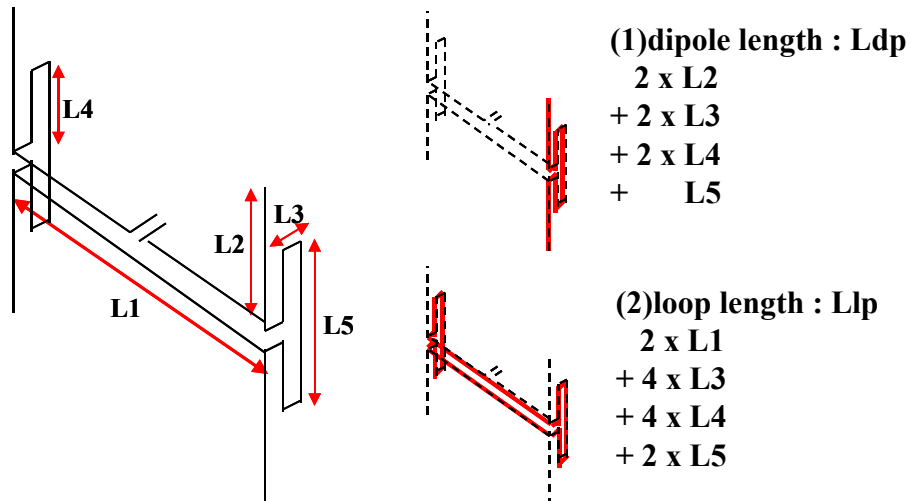

Fig.3 Configuration

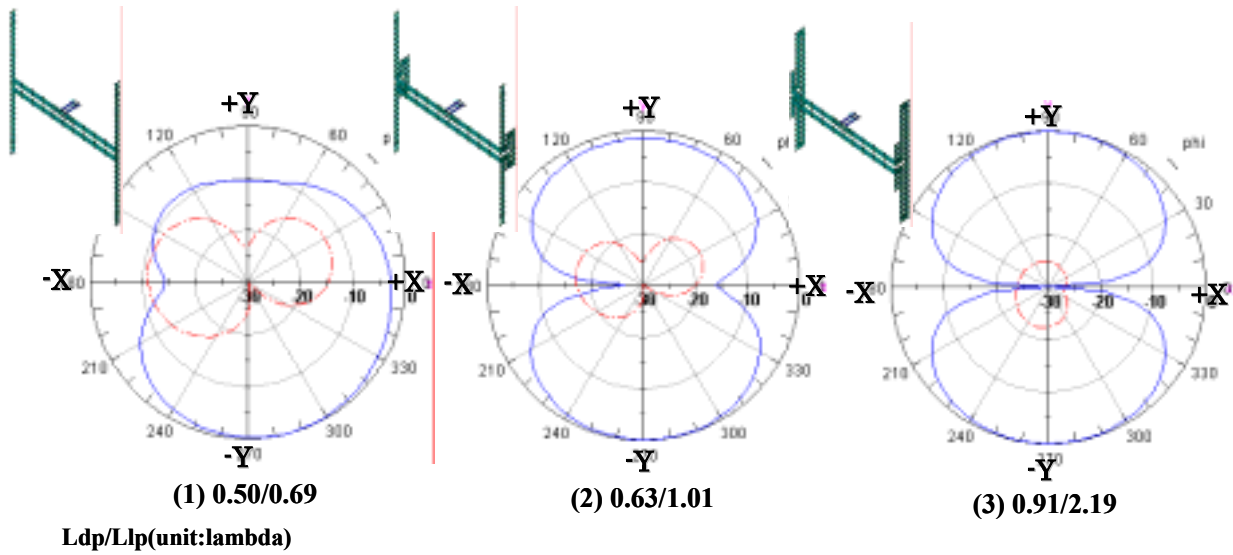

Fig.4 each length and radiation pattern

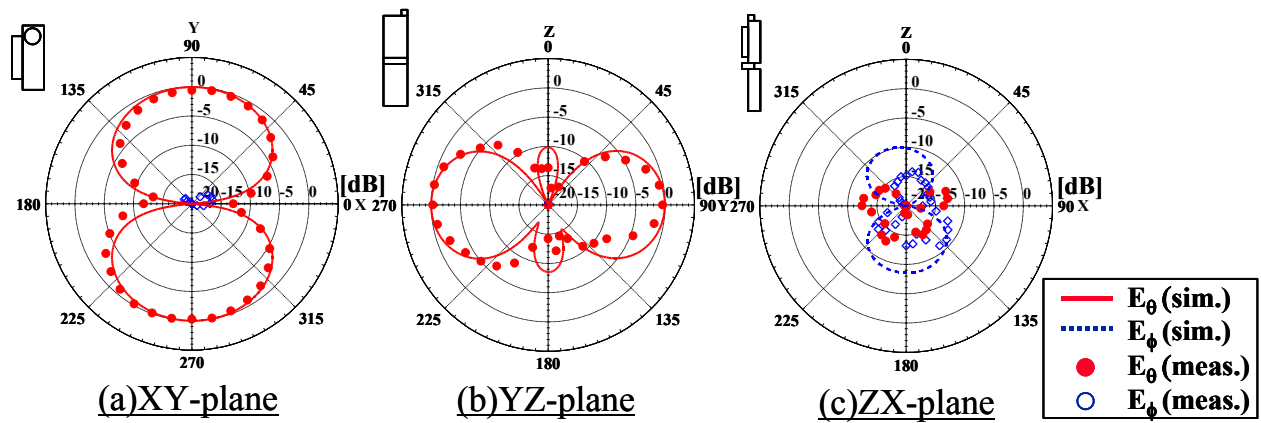

Fig.5 radiation patterns of simulation and measurement

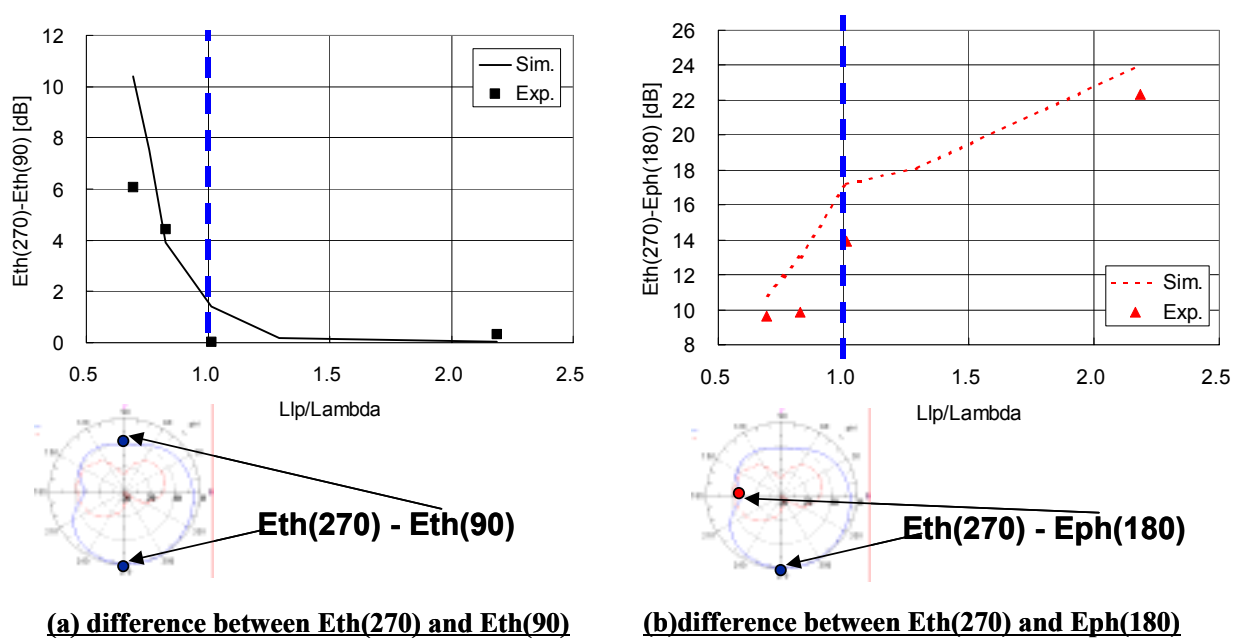

Fig.6 differences of radiation intensity