

# A Compact Dual-Band Circularly Polarized Spiral Antenna

Mayumi Matsunaga

Dept. of Electrical and Electronic Engineering, Ehime University, 3 Bunkyo-cho, Matsuyama, Ehime 790-8577 Japan

**Abstract** - A novel dual-band circularly polarized (CP) antenna is presented. The antenna is constituted by spiral elements and a dipole feeder. The spiral elements bent like a cross shape radiate circularly polarization in wide directions. By feeding the spiral elements through a dipole feeder, the presented antenna achieves radiating CP waves at two bands. The configuration and simulated characteristics of the antenna is presented. Simulation results show that the antenna radiates good CP waves at 1.93 GHz and 2.8 GHz. The 3 dB axial ratio (AR) bandwidths are 6 MHz and 70 MHz, respectively. The 3 dB AR beam-width is 80°.

**Index Terms** — Circularly polarized antennas, compact, low-profile, wideband, omnidirectional, planar.

## 1. Introduction

Omnidirectional circularly polarized (CP) antennas are very useful equipment for satellite communications, indoor wireless communications and so on. In particular, for studies using satellite beacon signals such as the ionosphere observation, omnidirectional CP antennas are an essential element because the angles of azimuth, elevation, and polarization of Beacon signals are uncertain. Moreover, a multi-band one port CP antenna is necessary for receiving many beacon bands as keeping the same phase center at every band for observation of the ionosphere.

The Lindenblad antenna is well known as an omnidirectional CP antenna for receiving satellite signals [1]. The Lindenblad antenna is configured by four sequential folded dipoles; therefore it can radiate omnidirectional CP waves. However, the size and configuration of the Lindenblad antenna is too big to constitute as base stations or install in satellites. For the ionosphere observation, the compact wide beam CP antenna which can receive many beacon bands is necessary.

The author has invented a compact and planar CP antenna—CSA—which radiates omnidirectional CP waves with one port feed [2]. The CSA is a planar spiral antenna which is constituted by spiral elements bent like a cross shape. The cross shape spiral elements can be thought equivalent to two folded dipoles orthogonally connecting in series. This configuration is the same as that of the Lindenblad antenna. For this reason, CSA radiates CP waves in wide directions. In addition, by using a dipole element as a feeder, CSA can be fed through a coaxial cable directly [3].

In this paper, the fact that a dipole fed CSA can radiate good CP waves at two bands is presented. The presented

antenna is a new arrangement of CSA and achieves the Lindenblad antenna in a planar structure.

## 2. The Structure of the Antenna

Fig. 1 shows the antenna structure presented in this paper. Detailed measurements of the structure, when the dielectric substrate whose  $\epsilon_r$  is 3.9,  $\tan\delta$  is 0.008, and thickness is 1.6 mm is used, are shown in Table 1. The cross-shaped spiral elements (CSE) are fed through a dipole feeder put in the center of the CSE. This means that the CSE is a parasitic element and the dipole feeder has a feed port. Two gaps with the measurement “g” are made into the element in order to constitute the antenna like two folded dipoles orthogonally connecting in parallel.

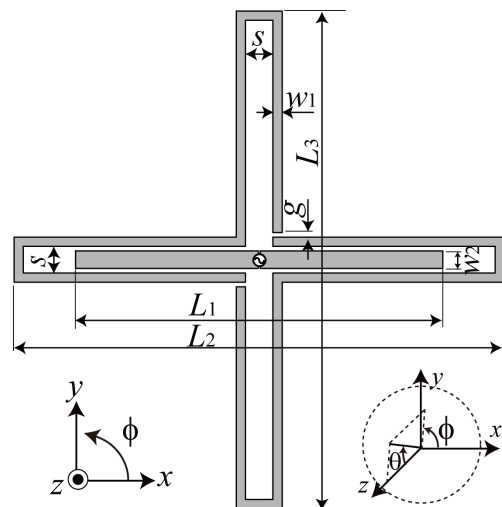

Fig. 1. Top view of the proposed antenna.

TABLE I  
Dimensions of the Prototype Antenna

$L_1$	$L_2$	$L_3$	$s$	$w_1$	$w_2$	$g$
40	53.4	54.2	3	1	2	0.5

## 3. The Characteristics of the Antenna

Fig. 2 shows  $S_{11}$  characteristics of the antenna, whose measurements are set as shown in Table 1.  $S_{11}$  of the presented antenna is lower than  $-10$  dB within 40 MHz, 20 MHz and 10 MHz around 1.3GHz, 1.93 GHz and 2.2 GHz respectively.  $S_{11}$  are about  $-8$  dB around 2.8 GHz.

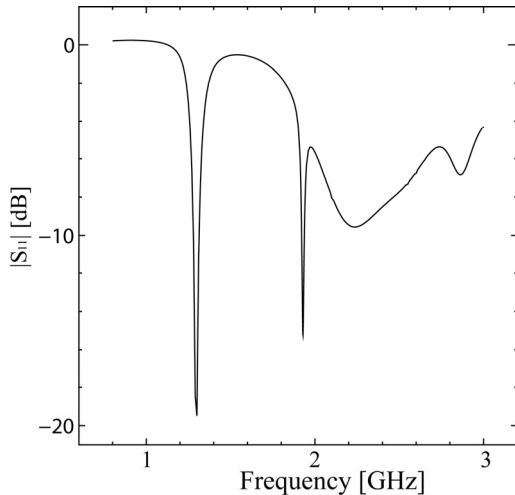

Fig. 2.  $S_{11}$  characteristic of the presented antenna.

CP waves are radiated at 1.93 GHz and 2.8 GHz, and linear polarized (LP) waves are radiated at 1.3 GHz and 2.2 GHz. Therefore, the presented antenna is quadruple-band multi-polarization antenna that can radiate not only CP waves at dual bands but also LP waves at dual bands.

Fig. 3 shows radiation patterns of CP waves at 1.93 GHz at the elevation plane in the  $\phi = 0^\circ$  cut. Fig. 4 shows radiation patterns of CP waves at 2.8 GHz at the elevation plane in the  $\phi = 0^\circ$  cut. Note that the angle  $\theta$  and the angle  $\phi$  are defined based on the basic spherical coordinate system shown in Fig. 1.

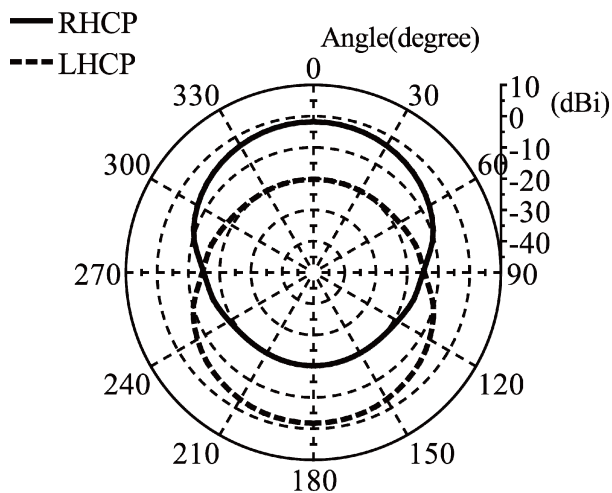

Fig. 3. Radiation patterns of CP waves at 1.93 GHz at the elevation plane in the  $\phi = 0^\circ$  cut.

At the 1.93 GHz, the maximum gain is -1.7 dBi and the 3dB AR beam-width is about  $80^\circ$ . At the 2.8 GHz, the maximum gain is 2.8 dBi and the 3dB AR beam-width is about  $80^\circ$ .

Fig. 5 shows the frequency characteristics of axial ratio and gain. The 3dB AR bandwidths are 6MHz around 1.93 GHz and 70 MHz around 2.8 GHz.

$S_{11}$  characteristics should be improved in the future works.

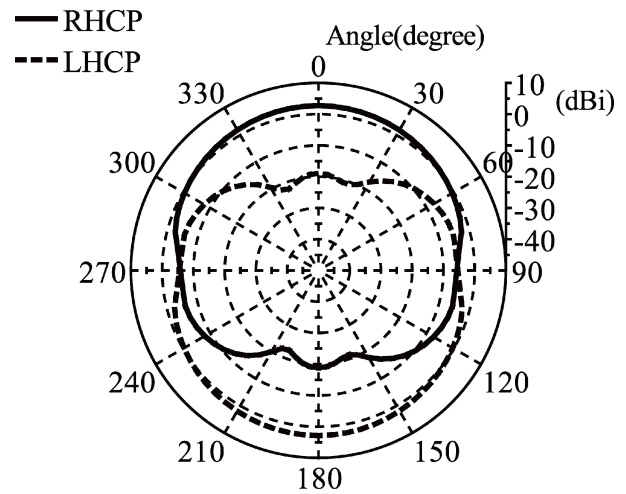

Fig. 4. Radiation patterns of CP waves at 2.8GHz at the elevation plane in the  $\phi = 0^\circ$  cut.

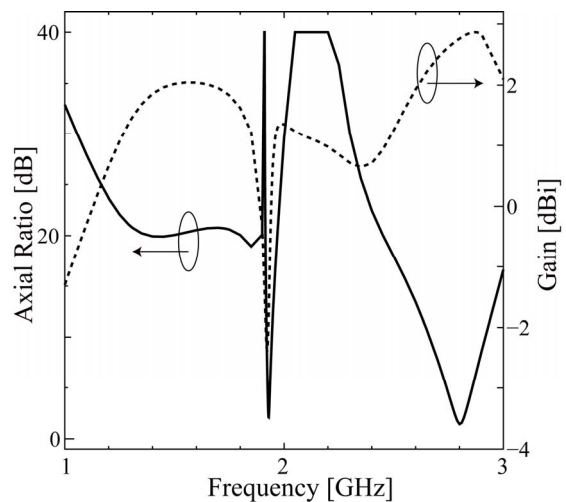

Fig. 5. Frequency characteristics of AR and gain.

### Acknowledgment

This work was supported by JSPS KAKENHI Grant Numbers 26420359 and 15H02135. The author would like to thank the Research Institute for Sustainable Humanosphere of Kyoto University.

### References

- [1] H. Sodja, "The Lindenblad: The ultimate satellite omni antenna," Sep. 7, 1995 [Online]. Available: <http://www.amsat.org/amsat/articles/w6shp/lindy.html>
- [2] M. Matsunaga, "A Linearly and Circularly Polarized Double-Band Cross Spiral Antenna," *IEICE Trans. Commun.* vol. E99-B, no. 2, pp. 430-438, Feb., 2016.
- [3] M. Matsunaga, "A Dipole-Fed Multi-Band Spiral Antenna," *Proc. Antennas Propag. Society International Symposium (APSURSI)*, pp.940-941, July 2013.