

An Efficient Design Method of a Folded Inverted-L Antenna Including a Matching Circuit

Takashi Yamagajo, Yohei Koga and Manabu Kai
 Network Systems Laboratory, Fujitsu Laboratories Limited, 1-1,
 Kamikodanaka 4-chome, Nakahara-ku, Kawasaki, Japan

Abstract - An efficient design method of a folded inverted-L antenna including a matching circuit is studied. The low profile antenna element is placed at the corner of the finite ground plane. The antenna is not electrically small because the ground plane contributes to the far field radiation and its size is comparable to the wavelength of the operating frequency. The antenna is matched to 50Ω with the aid of the matching circuit. Optimal antenna length and matching circuit type to design the antenna which shows broadest bandwidth are investigated. The results indicate that the studied antenna can be designed using one dimensional optimization method.

Index Terms — inverted-L antenna, matching circuit, antenna Q, IoT.

1. Introduction

Recently, IoT (Internet of Things) has gained considerable attention to extract new value by analyzing various data in the real world [1]. In the IoT applications, wireless devices are equipped in a wide variety of instruments such as electrical appliances and smart meters [2]. The antenna of the wireless device should be designed depending on the instruments and the application, since optimal antenna structure varies depending on its operating frequency, size and nearby environment. Establishment of the efficient antenna design methodology will be welcomed for the wide and fast spread of the IoT. We have been studied the antenna design method for the IoT instruments [3]. As a part of this research, efficient design approach for the low profile antenna including the matching circuit is proposed.

The antenna element studied in this paper is placed at the corner of the system ground plane of the IoT instrument. The ground plane has dimensions comparable to the wavelength of the operating frequency and contributes to the far field radiation [4]. So, the antenna is not electrically small. For the fixed antenna element area, optimal element length and matching circuit type to achieve broadest bandwidth are investigated. Furthermore, effectiveness of the quality factor Q as the measure of the bandwidth is examined. Based on the results of the study, efficient way of designing the antenna is discussed.

2. Antenna Structure and Matching Circuit

Investigated antenna structure is shown in Fig.1. The antenna element is placed at the corner of the fixed ground plane. The size of the ground plane is $\lambda \times \lambda$, where λ is the wavelength of the operating frequency. The antenna is a folded inverted-L antenna (ILA). The width of the antenna

element is $\lambda / 200$. The area of the antenna element is restricted by $H \times W$. In case that total element length L becomes longer than $H + W$, the antenna element is folded in a spiral manner. For simplicity, the ground plane and the antenna element is modeled as a perfect electrical conductor.

Two lumped elements are used to match the input impedance 50Ω . Depending on the antenna input impedance Z_a , there are eight types of matching circuit as shown in Fig.2. The values of the lumped elements can be calculated analytically by using Z_a .

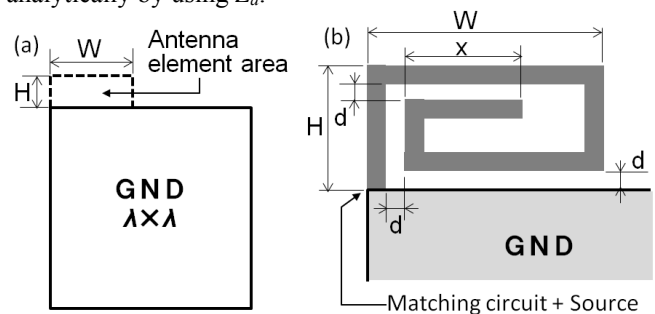

Fig. 1. Investigated antenna, (a) overall view, (b) antenna element. The “d” in the figure is $\lambda / 200$. The total element length L is $3H + 2W + x - 4d$.

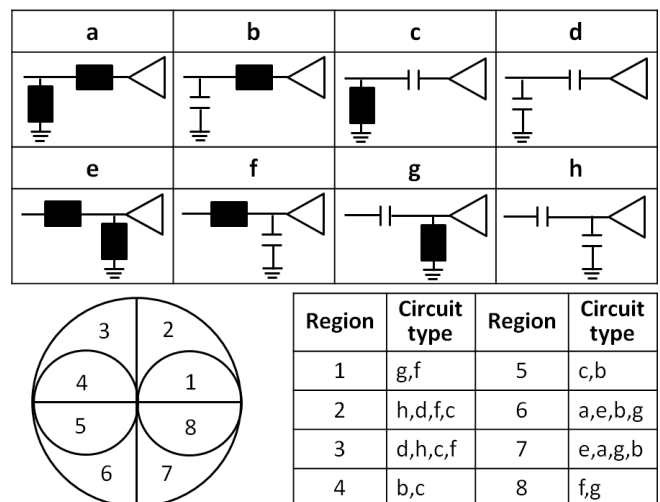

Fig. 2. Matching circuit types, impedance regions in the smith chart and corresponding matching circuit type(s).

3. Simulation Results and Discussion

By changing L, antenna input impedance is simulated by the commercial electromagnetic simulator CST MW-

STUDIO [5]. For each L, optimal matching circuit with which broadest bandwidth is achieved, is selected among the eight types of the circuit shown in Fig.2.

The matched VSWR bandwidth FBW_v of the antenna is plotted against L in Fig. 3(a). FBW_v is defined as the difference between the two frequencies at which the VSWR equals a given threshold s [6]. In this study, s is 2.0. The height H of the element is $\lambda / 50$ and no restriction for the width W. Broadest bandwidth is achieved at $L \approx 0.2 \lambda$. Input impedance of this antenna is $18.2 - j34.3 \Omega$. So, broadest bandwidth is achieved with the non-resonant antenna. Two types of Q , Q_V and Q_z , are evaluated for the antenna shown in Fig 3(a). Q_V and Q_z are calculated from FBW_v and Z_{am} respectively. Z_{am} is the input impedance of the antenna with the matching circuit. They are expressed as follows.

$$Q_V(\omega_0) = \frac{s-1}{\sqrt{s} \text{FBW}_v \omega_0}, \quad Q_z(\omega_0) = \frac{\omega_0 |Z_{am}(\omega_0)|}{2R_0}$$

$R_0 (= 50 \Omega)$ is the reference impedance and ω_0 is the operating angular frequency. Q_V and Q_z are plotted in Fig. 3(b) and it shows that Q_V and Q_z coincides as written in Ref. [7]. Q_V simulation usually requires longer computational time than Q_z for frequency domain simulators. So, Q_z should be used as a measure to optimize the antenna element length.

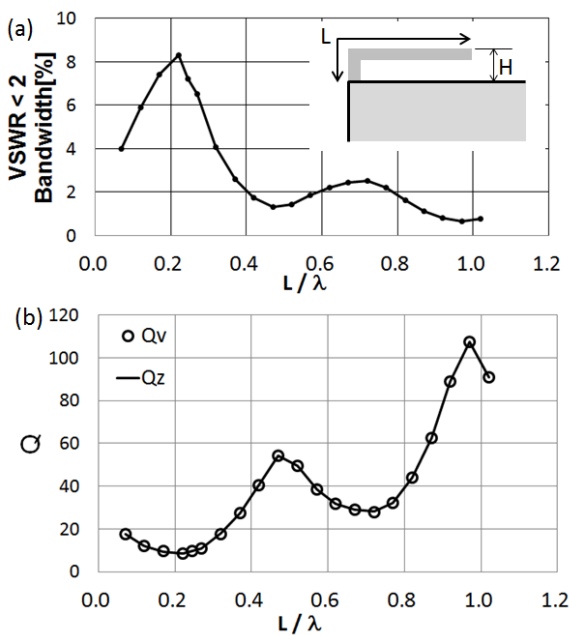

Fig. 3. (a) VSWR < 2 bandwidth of the input impedance of the antenna including matching circuit, (b) L dependence of Q . $H = \lambda / 50$.

Next, antenna element area dependence of the bandwidth is investigated. The height H of the antenna element is $\lambda / 30$. In Fig.4, Q_z for various W is plotted. Fig.4 shows that the antenna length for minimum Q_z becomes short as the antenna area becomes small. This result indicates that the reactive stored energy around the antenna elements increases as the antenna element area decreases. For further study, near field distribution of the antenna should be investigated [8].

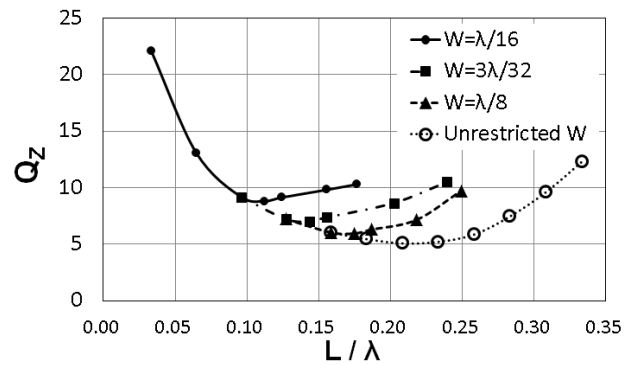

Fig. 4. L dependence of Q_z for various W. $H = \lambda / 30$.

In all cases mentioned above, optimal matching circuit type is “type a” shown in Fig.2. Element values of the circuit can be calculated analytically from Z_a . Therefore, optimization of the antenna with matching circuit reduces to simple one dimensional minimization problem. The parameter optimized is element length L and the evaluation function is Q_z . L is optimized to minimize Q_z in the range of $L < \lambda / 4$. The antenna with minimized Q_z shows the broadest bandwidth.

4. Conclusion

Properties of the low profile folded ILA with the matching circuit placed at the corner of the fixed ground plane are investigated. Non resonant antenna with its element length shorter than $\lambda / 4$ shows the broadest bandwidth. Optimal antenna element length becomes shorter as the antenna area becomes smaller. For the optimal antenna element length, matching circuit type is uniquely determined. It is examined that the quality factor calculated from the input impedance of the antenna with the matching circuit is a good measure for the bandwidth. These results indicate that the studied antenna can be designed using one dimensional optimization method.

References

- [1] K.Yoshihara and M.Hattori, “Device mManagement for M2M and IoT applications”, Journal of IEICE, vol.99, no.1, pp.42-46, 2016 (in Japanese).
- [2] A. Loutridis, M.John, M.J. Ammann, “Folded Meandered Monopole for Emerging Smart Metering and M2M Applications in the Lower UHF Band Wireless Corner”, IEEE Antennas and Propagation Magazine, vol.58, no.2, pp.60-65, 2016.
- [3] T.Yamagajo, Y. Koga and M. Kai, “A Study on the Design Method of the Low Profile Antenna with Matching Circuit”, Proceeding of the IEICE general conference, B-1-155, 2016 (in Japanese).
- [4] P. Vainikainen, J. Ollikainen, O. Kivekäs, and I. Kelder, “Resonator-based analysis of the combination of mobile handset antenna and chassis”, IEEE Trans. Antennas Propag., vol. 50, no. 10, pp.1433–1444, 2002.
- [5] <https://www.cst.com/Products/CSTMWS>
- [6] A.D.Yaghjian and S.R.Best, “Impedance, Bandwidth, and Q of Antennas”, IEEE Trans. Antennas Propag., vol.53, no.4, pp.1298-1324, 2005.
- [7] M. Capek, L. Jelinek and P.Hazdra, “On the Functional Relation Between Quality Factor and Fractional Bandwidth”, IEEE Trans. Antennas Propag., vol.63, no.6, pp.2787-2790, 2015.
- [8] H.Arai, “Antenna Clearance, an Index Factor for Electrical Size of Small Antennas”, pp.91-94, International Workshop on Antenna Technology (iWAT), 2008.