

Design of a WLAN Monopole Antenna with Dual-Band Plus Extended Bandwidth

Chi-Fang Huang* and Shu-Yi Lin
 Graduate Institute of Communication Engineering
 Tatung University
 40, Chungshan N. Rd., 3rd Sec., Taipei 104, TAIWAN
 Tel: +886-937-008-883; Fax: +886-2-2599-1037
 email: ras@ttu.edu.tw

1. Introduction

Monopole antenna [1] is the most popular type of antennas used in varied applications including military, industrial and civil wireless communications. This project intends to design a monopole antenna used for a Wireless LAN [2] application, in which, the antenna is working with a USB-based transceiver, see Figure 1. What shown in the Figure 1 is applied in a Microsoft XBOX 360 game station [3]. In theory, the length of a monopole is designed to be a quarter-wavelength ($\lambda_0/4$) in free space of the frequency of system. Consequently, the multiple- $\lambda_0/4$ behaviour may happen in frequency response, see Figure 2. This response of return loss of a monopole antenna looks like a one of multi-band, if the propriety of the associated radiation patterns is not concerned. Also, since the monopole antenna is a $\lambda_0/4$ -based design, its individual band is narrow in characteristics. Other than its natural multi-band, if an assigned dual-band is necessary and one of this dual-band is needed to be ultra wide, such a design will be difficult. The present work is to aim at such a goal. This specification in terms of band is wanted in some countries, for example, Japan or Korea, where the WLAN adopting IEEE 802.11j uses the spectra that are not exactly the same as that used in northern America or Europe; yet overlapping on each other is possible.

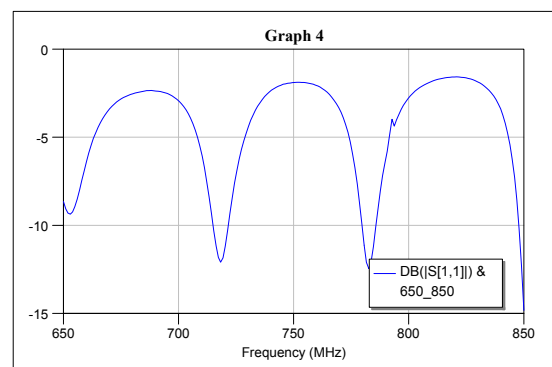

Figure 1: A monopole antenna used in WLAN Figure2: Multi-band nature of a monopole antenna

Wireless LANs have quickly become a significant role in the LAN market, mainly because of its mobility for users. The physical layer standards IEEE 802.11a/b/g bands are the most popular ones currently in WLAN. IEEE 802.11a operates in the 5 GHz band (5.1~5.8GHz or so) at data rates up to 54Mbps, IEEE 802.11b operates in the 2.45 GHz band (2.412~2.484GHz) at 5.5 and 11 Mbps. However, different portions of the 5GHz band are approved in different countries. For example, the U.S. and Canada currently allow Wi-Fi to operate in both of the 5.15 ~ 5.35 GHz band

and the 5.725 ~ 5.825 GHz band. Europe allows it to operate in these bands and also in the 5.47 ~ 5.725 GHz band.

In addition to covering the 2.45GHz band and the whole 5GHz band (from 5.15GHz to 5.825GHz), the monopole antenna designed here is to extend the spectrum down to 4.9GHz for the wireless applications in some countries, for example, Japan, where the standard IEEE 802.11j is adopted. Consequently, for the purpose of covering all these standards, a dual- and wideband monopole antenna is designed.

2. Proposed Structure for Dual-Band plus Extended Bandwidth

Referring to the Figure 3 and Figure 4, the proposed structure of antenna being designed is shown. Firstly, because that a monopole antenna is ground-sensitive type of antenna, a cylindrical section of metal is used to be the ground. Based on a normal metal wire usually used in the monopole antenna, a “loaded cup” is carefully designed and added on this wire. This device is to play the key role to create the dual-band and to broaden width for the higher spectrum. The detail dimensions of this cup and its gap from the cylindrical ground mentioned above need to be searched for in the phase of computer simulation. CST [4] package is used as the electromagnetic simulation tool in this work. All of these components are contained in a plastic radome, whose final appearance is also shown in the Figure 1. This radome is supposed to be an extra loading element of this antenna, and its effect on the antenna performance is to be discussed in the following. There is lack of a large ground plane considered in theory, therefore, as what expected, the feeding cable will be a part affecting the antenna performance, especially the frequency response. Without a large ground plane, induced current will be produced on the cable. For the purpose of precise design, the feeding cable is thought as a part of the antenna.

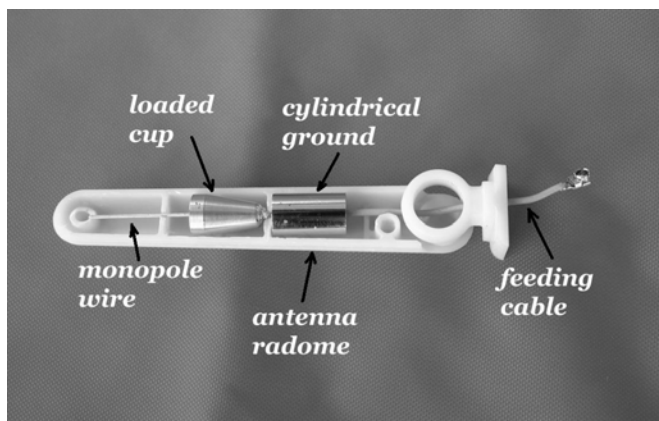

Figure 3: Complete components of the proposed antenna

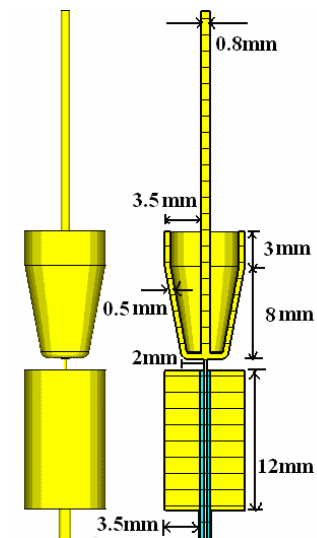

Figure 4: Dimension details of antenna

3. Design and Analysis by Simulation and Measurement

By employing the EM package CST to help design, resonant behaviour of antenna can be predicted very well. In the Fig. 5, it shows the result of the monopole wire's resonance with and without the loaded cup. The higher band above the 5GHz is only possibly created when this cup is added, so it proves the significance of this design of using such a loaded element. And Fig. 6 depicts that, the monopole wire's length indeed influences the allocation of resonant band just like a traditional one, anyway, it mainly affects the 2.45GHz band by our choice of wire length. On the other hand, after attaching the loaded cup, its dimension can be used to precisely adjust the higher

spectrum of 4.9GHz~5.85GHz. It is worth to mention that, the gap between the loaded cup and cylindrical ground shown in the Fig. 3&4 is also a critical parameter in adjusting the higher band.

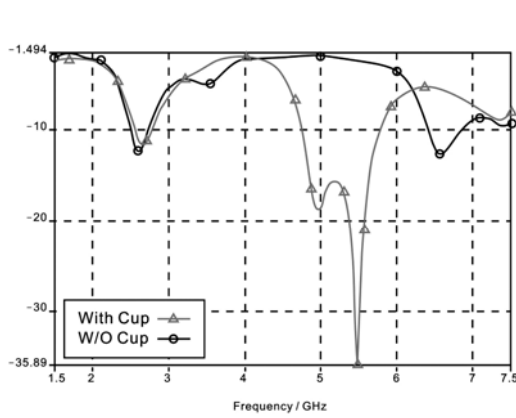

Figure 5: Frequency response of a monopole wire with and without loaded cup

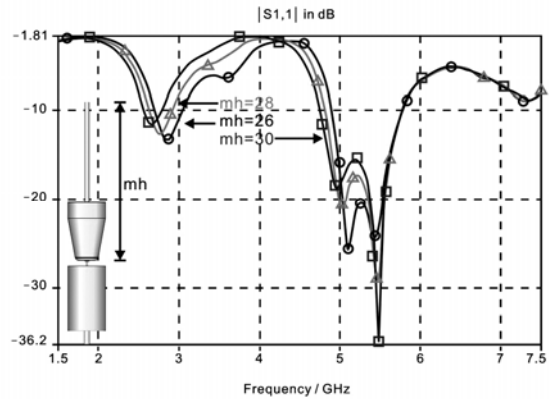

Figure 6: Frequency response due to varying length of the monopole wire

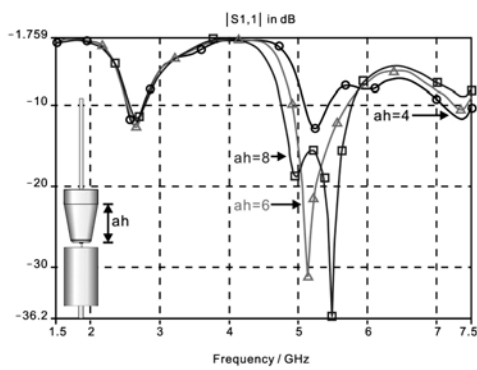

Figure 7: Frequency response due to varying dimension of the loaded cup

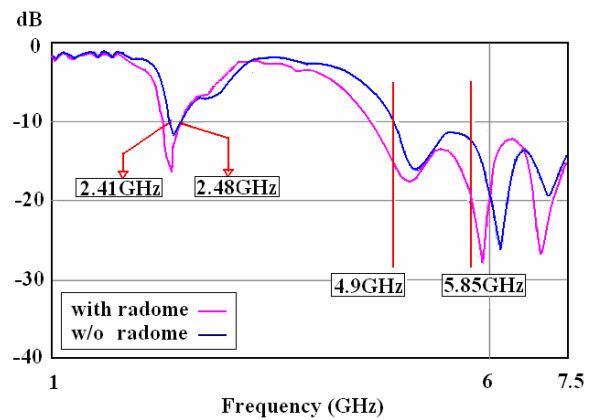

Figure 8: Resultant frequency response with and without a radome

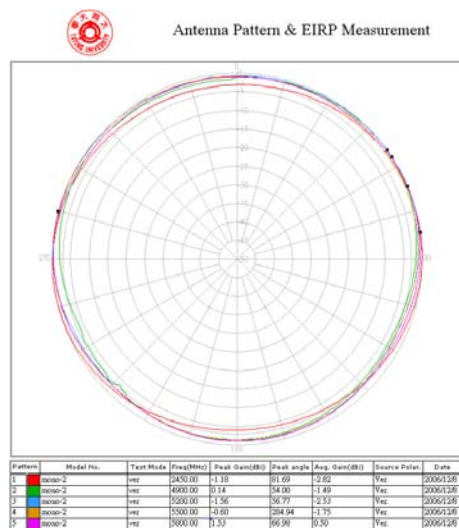

Fig. 9 Measured radiation patterns

Fig. 8 shows the resultant frequency response of antenna's return loss. Most of important, the effect of the antenna radome has been investigated as well. Usually, the material of radome, for instance, plastics, has higher loss tangent in higher frequency, and makes the antenna efficiency lower. By the shown cures, the radome affects the return loss very obviously when frequency is above 4GHz approximately. Fortunately, with or without the radome, the frequency response of return loss of antenna meets the specification of target design both in the lower band and in the higher band. Firstly, the return loss in the band of 2.41~2.48GHz is indeed below -10dB. From 4.9GHz up to 7GHz, the return loss is well below -10dB. Therefore, the design for a monopole antenna of dual-band with extended bandwidth is achieved. All these measured data are of the monopole antenna using a feeding cable of 55mm length.

Fig. 9 shows the measured radiation patterns of frequencies 2.45, 4.90, 5.20, 5.50 and 5.8GHz. In such a measurement, the vertical polarization is considered only, because it is the main wave polarization in an environment of wireless LAN. All the displayed measured radiation patterns have a characteristics being omni-directional, which is very essential in the wireless LAN too.

4. Conclusion

This paper is resulted from a work of designing a monopole antenna, which owns dual-band meeting the spectrum standard of IEEE 802.11 a/b/g and that in Europe. However, it has extended the 5GHz spectrum down to 4.9GHz to meet the IEEE 802.11j standard which is adopted by some countries. By adding an extra loaded element on a monopole wire, the dual-band and extended bandwidth are created simultaneously. Such a design is potentially able to be applied to the game market, for example, the Microsoft Xbox and the others, which uses WLAN for a "team playing", for instance, "Xbox live" through Internet.

Acknowledgments

This work was granted by Forward Electronics Co., Ltd. [5], Taipei County, TAIWAN. Forward Electronics is deeply appreciated for its long-term support for Tatung University in the R&D activities.

References

- [1] E. C. Jordan and K. G. Balmain, *Electromagnetic Waves and Radiating Systems*, 2nd Ed., Prentice-Hall, 1968.
- [2] I. J. Wickelgren, "Local-area networks go wireless," *IEEE Spectrum*, Vol. 33, no. 9, pp. 34-40, Sept. 1996.
- [3] www.xbox.com
- [4] "CST User's Manual," <http://www.cst.com/>
- [5] <http://www.fwd.com.tw/>