

Performance Evaluation of RF Transceiver for DS-CDMA UWB System

Il-kyoo Lee, Dong-yeal Lee*, Seung-hyeub Oh*, Bub-joo Kang**
 Kongju National Uni./Chung-Nam National Uni.*, Dong-gook Uni.**
 Information & communication Dept., Kongju National Uni., 182, Shinkwan -Dong,
 Kongju-City, Chungnam,314-701, Korea.
 E-mail: leeik@kongju.ac.kr

1. Introduction

Recently, studies on UWB (Ultra Wide Band) have been under going very actively as technology for high speed, low power consumption, accurate location information, and low-cost data transmission. The UWB is suitable for short distance communication requiring high speed and large capacity of data transmission since it spreads from DC to several GHz. The UWB technology has been developed largely for distance measurement, military communication device and signal detection in under-ground. The Federal Communications Commission (FCC) defined UWB system as a system having Fractional Bandwidth of 20 % above or RF bandwidth of 500 MHz above in 2002. In the beginning, Impulse method using short pulse was suggested as an implementation method. For the flexible application of bandwidth, Multiband-Orthogonal Frequency Division Multiplexing (MB-OFDM) and Direct Sequence-CDMA(DS-CDMA) methods are on the discussion in International Standard Committee these days.

In specific, the DS-CDMA method has an advantage of low power level and good security since it spreads the signal with wideband sequence. In this paper, the interface and performance requirements of RF transceiver for UWB system based on DS-CDMA are introduced. Major components such as Low Noise Amplifier (LNA), Power Amplifier (PA) and Band Pass Filter (BPF) are designed and fabricated to meet UWB characteristics. By using the fabricated RF components and commercial devices, the RF transceiver for UWB system was designed and implemented. The simulation was carried out to analyze the performance of the transmitting and receiving path. In order to evaluate the performance of the implemented RF transceiver, the W-CDMA signal generator and signal analyzer were used. The design and implementation approach of RF transceiver were verified by comparing the measurement results with the requirements.

II. Performance requirements of RF transceiver for DS- CDMA UWB

The FCC of U.S.A. released the spectrum emission of UWB system on the frequency band of 3.1 GHz ~ 10.6 GHz and Korea also defined the spectrum emission in domestic as in figure 1.

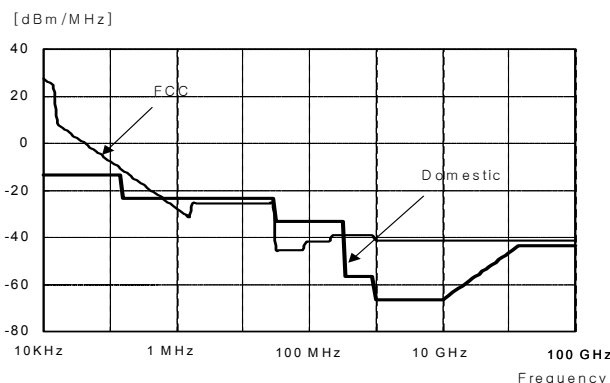

Figure1. Spectrum emission mask of UWB in Domestic and U.S.

The maximum path loss in UWB system is written by as follow

$$L_{path} [dB] = P_T + G_T + G_R - (S/N)_{req} + PG - 10 \log_{10}(N_0W) - NF - M$$

Here, P_T is maximum transmitting power, G_T is antenna gain of transmitter, G_R is antenna gain of receiver, $(S/N)_{req}$ is required minimum S/N of demodulator, PG is processing gain(bandwidth/data rate), N_0 is thermal noise /Hz (-174 dBm/Hz), W is bandwidth, NF is noise figure of receiver, M is demodulating margin. Parameters for path loss calculation of UWB system is summarized in table 1.

Table1. Path loss parameters for UWB system

Item	Domestic	FCC
P_T	1.78 [dBm]	27.18 [dBm]
G_T	0 [dBi]	0 [dBi]
G_R	0 [dBi]	0 [dBi]
$(S/N)_{req}$	14.1 [dB], (for BER 10^{-4})	14.1 [dB]
N_0	-174 [dBm/Hz]	-174 [dBm/Hz]
W	2 [GHz]	1 [GHz]
$10 \log_{10}(N_0W)$	-81 [dBm]	-81 [dBm]
PG	23 [dB], (for 10 Mbps)	23 [dB], (for 10 Mbps)
NF	10 [dB]	10 [dB]
M	10 [dB]	10 [dB]
<i>Max. L_{path}</i>	<i>77.38 [dB]</i>	<i>102.78 [dB]</i>

After considering above parameters, the requirements of RF transceiver performance for DS-CDMA UWB system are summarized in table 2.

Table2. RF performance requirements for DS-CDMA UWB

Items	Requirement	Unit
Frequency	3.1 ~ 5.1	[GHz]
Output level of TX	-10	[dBm]
Antenna gain of TX	0	[dBi]
Input level of TX	0	[dBm]
Antenna gain of RX	0	[dBi]
Input level of RX	-50 ~ -80	[dBm]
Noise Figure	7	[dB]
Output level of RX	0	[Bm]

Analog signal from Modem is modulated with QPSK and then is amplified with power amplifier. After being amplified, the signal is filtered and then transmitted through antenna. The received RF signal is low noise amplified and then demodulated with QPSK. The demodulated analog signal is applied to Modem after passing through Automatic Gain Control (AGC) process. The block diagram of RF transceiver is shown as in figure 2.

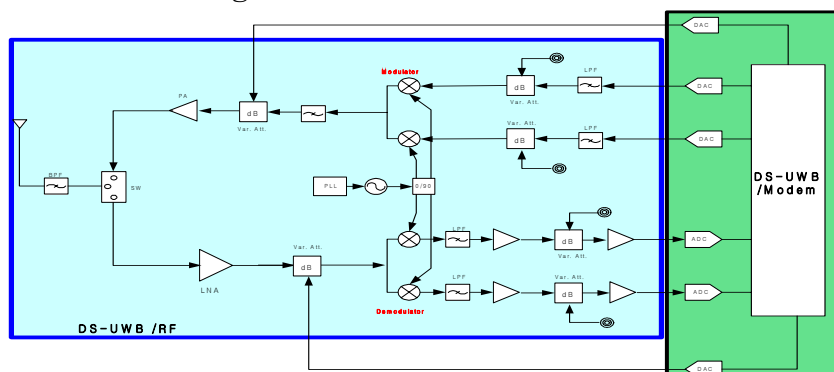

Figure2. RF transceiver block diagram for DS-CDMA UWB system

III. The RF transceiver implementation and performance evaluation

After considering main components of RF transceiver for DS-CDMA UWB, the characteristics of transceiver were analyzed with Syscal.4 simulator as in figure 3. As a result, the pass gain of -82.4 dB and the noise figure of 5.1 dB were obtained for receiver. The simulation results of transmitting path showed gain of 0 dB, output level of 0 dBm and OP1 dB of 8 dBm.

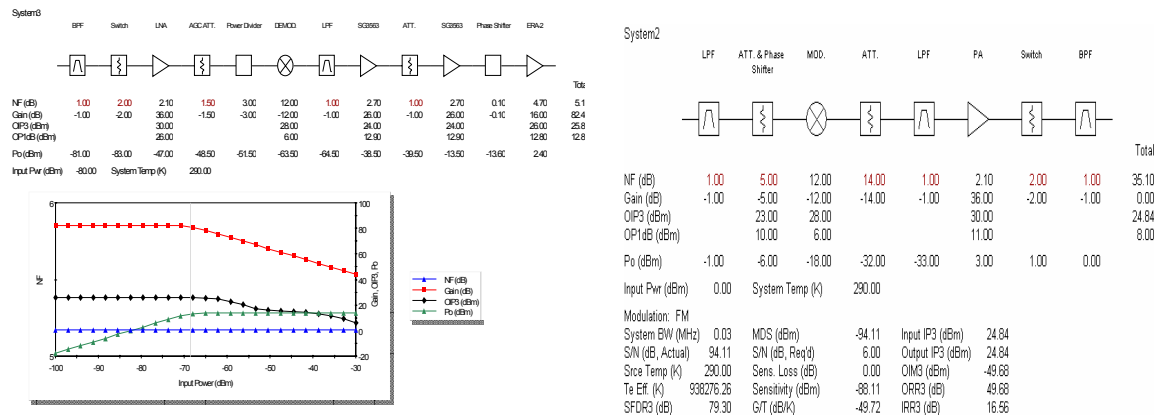

Figure3. Simulation results of receiving path and transmitting path

The RF transceiver for DS-CDMA UWB was implemented with fabricated components and commercial components as in figure 4. The transceiver has receiving path, transmitting path and frequency synthesizer.

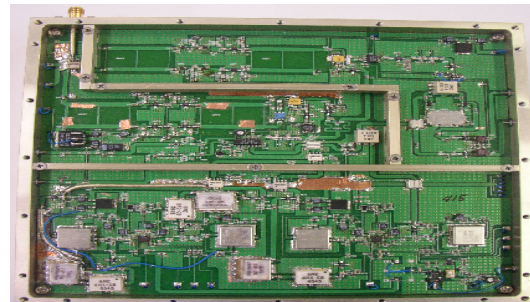

Figure4. Implemented RF transceiver for DS-CDMA UWB

In order to evaluate the transmitting performance, W-CDMA signal source and signal analyzer were used. The spectrum characteristic and constellation were measured at 3.978 GHz as in figure 5. Error Vector Magnitude (EVM) of 9.33 % was measured.

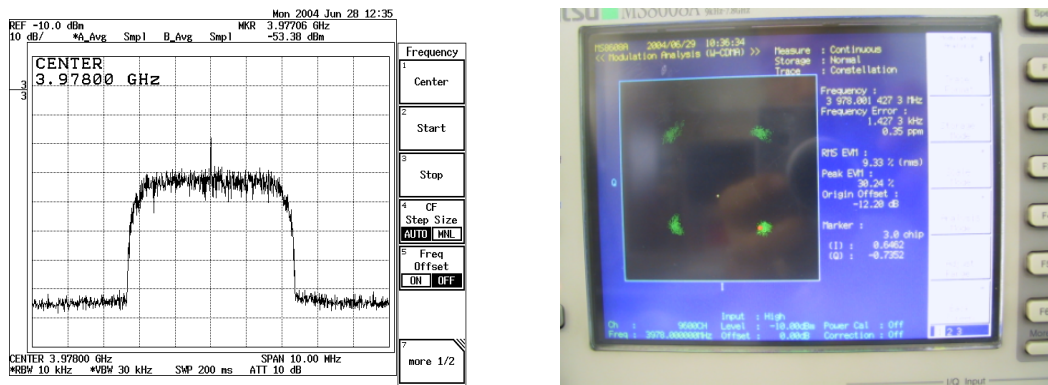

Figure5. Measured spectrum and constellation of UWB RF transmitter

