

## Radiated Electromagnetic Field from a Solar Cell for CISPR Radiated Emission Measurement Method

**Takaaki Mori, Masatake Shigenaga, Masamitsu Tokuda**

Research Division in Engineering, Graduate School, Musashi Institute of Technology  
1-28-1 Tamadutumi, Setagaya-ku, Tokyo, 158-8557 Japan  
E-mail: mori@csl.ec.musashi-tech.ac.jp

**Shoichi Suenaga, Hironobu Igarashi, and Kenichi Asami**

Research Division, Japan Electrical Safety & Environment Technology Laboratories  
5-14-12 Yoyogi, Shibuya-ku, Tokyo, 151-8545 Japan

**Abstract:** Radiated electromagnetic field from the solar cell is studied experimentally and theoretically in order to clear antenna effect of the solar cell. First, the radiated electromagnetic field of own made loop antenna was measured, and compared with calculated value in order to obtain the model of balun that is necessary for the measurement of the radiated electromagnetic field. As a result, it is conformed that the model of balun is almost appropriate. Next, solar cell was modeled by the conductor with limited resistance, and electric field strength radiated from the solar cell was computed by the method of moment. As a result, the calculated values for all position of the receiving antenna can be fit each other to measured values by using the electric conductivity of  $2.53 \times 10^3 \text{ S/m}$ .

### 1. Introduction

Since a power generation system by solar cell has a small load to the earth environment on power generation, it is hopeful as alternative energy source of an oil, and it's spread and promotion are performed by government and people. In this case, it is important for the system to comply with the electromagnetic emission standard specified by CISPR. Although the solar cell itself does not create a disturbance noise, a power conditioner converted from DC electric power to AC electric power becomes main disturbance wave source. This disturbance wave transmits through conducting wires, to the solar cell, and is emitted from that as a radiated disturbance wave[1]. In general, almost all equipment and system are already specified by CISPR, but the radiated and conducted emission standards intended for the power generation system by solar cell is not specified yet. JET (Japan Electrical Safety & Environment Technology Laboratories) has been studies the emission standard for the solar cell power generation system supported by NEDO (New Energy and Industrial Development Organization)[2]. If we try to measure the

disturbance wave from the power generation system having the solar cell in an anechoic chamber, we need to illuminate the solar cell by using an optical source similar to sun. It is very difficult to obtain such an optical source, and then it is necessary to measure the disturbance wave from the power generation system without the solar cell. In this case, we need to know the radiation property from the solar cell including the conducting wires jointing the solar cells each other.

In this paper, we try to measure and calculate the radiation property from the solar cell in order to apply the radiated emission measurement method specified by CISPR. We also study to measure and calculate a simple loop antenna made by ourselves in order to check the measurement and calculation methods.

### 2. Measurement method of radiated electric field

We measured the radiated electric field from EUT (Equipment Under Test) such as a solar cell or our own made loop antenna in an anechoic chamber as shown in Fig.1. Since input terminal of the solar cell has balanced wires, we have to use a balun in order to convert an unbalanced coaxial terminal from a signal generator. The radiated electromagnetic wave from the solar cell is detected by a biconical antenna, which is set at 3m apart from the solar cell. The output signal from the biconical antenna is detected by the EMI (Electromagnetic Interference) receiver, and we can obtain the electric field from the solar cell or own made loop antenna. The measured frequency range is from 30 MHz to 300 MHz corresponding to the biconical antenna. The output level of the signal generator is 10 dBm (about 0.7V). The size of the measured solar cell is 802mm wide, 1200mm high and 46mm thickness, and the measured loop antenna is made by winding a vinyl coated copper wire with a copper diameter of 0.99mm on a wooden board (185mm wide, 1502mm high, 35mm thickness).

We measured 3 receiving antenna positions to the direction of the EUT as shown in Fig.1. Fig.1(a) shows the case that the receiving antenna set on direction of front face for the EUT and the height of a receiving antenna is set to 73cm. Fig.1(b) shows the case set on the direction of side face for the EUT, that is the case rotating 90 degree to the case as shown in Fig.1(a). Fig.1(c) shows the case that the EUT is inclined about 70 degree from the position as shown in Fig.1(a) and the receiving antenna is set on the point of 3m away from the center of the EUT.

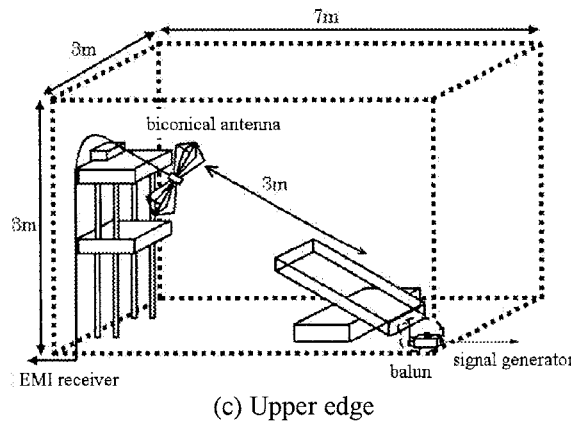
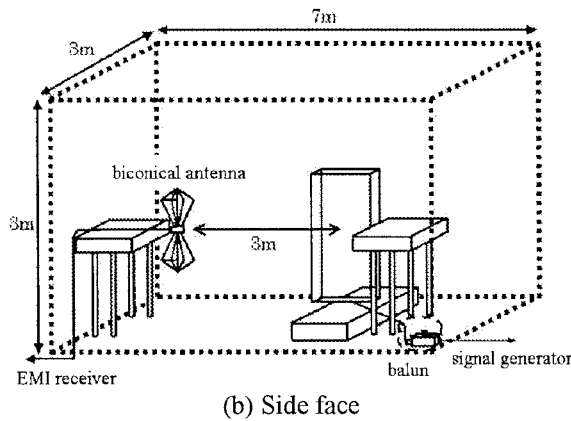
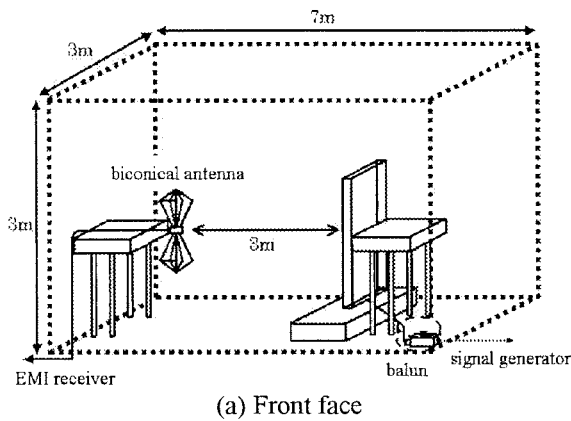

Figure 1. Measurement system of radiated electromagnetic field from solar cell or own made loop antenna

### 3. Calculation method of radiated electric field

The radiated electric field from the solar cell and own made loop antenna is calculated by using NEC (Numerical Electromagnetic Code) that is a general-purpose program soft by the method of moment.

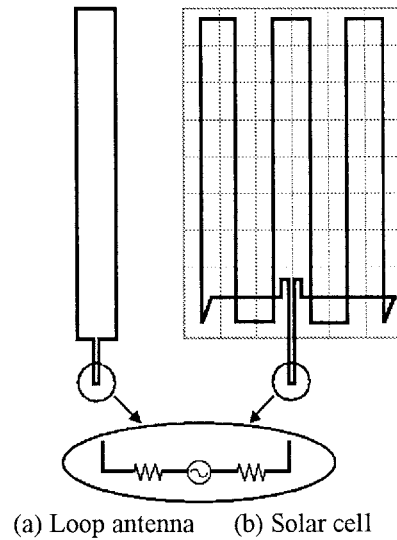

Figure 2. Calculation model

The calculation model of the loop antenna is shown in Fig.2 (a). A short twisted wire is connected between input part of the loop antenna and balun, but the twisted wire assumed parallel wire as shown in Fig.2 (a). Moreover, in order to make a model for output part of balun, a series of two resistors of 50 Ω are set at the input part of parallel wire, and voltage source of 0.7V is inserted between two resistors as shown in lower part of Fig.2.

With the solar cell used for an experiment, a series of cells are connected each other and lined up, but we assumed that a metal wire are set as shown in Fig.2 (b) instead of a series of solar cells. The conductivity of the metal wire is set on  $2.53 \times 10^3 \text{ S/m}$  so as to fit the measured data of the electric field strength for the solar cell as shown in Fig.4. Input part of the solar cells is modeled with that similar to the loop antenna as shown in lower part of Fig.2.

### 4. Electric field characteristics of the loop antenna

The measured and calculated frequency characteristics about electric field strength from own made loop antenna are shown in Fig. 3. The electric field has three components such as the horizontal, vertical and radial directions and then vector sum of the three components is plotted in Fig.3.

We measured 4 receiving antenna positions to the direction of the loop antenna as shown in Fig.3.

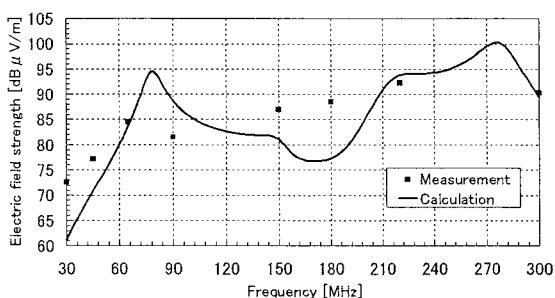

(a) Front face (receiving antenna height of 73cm)

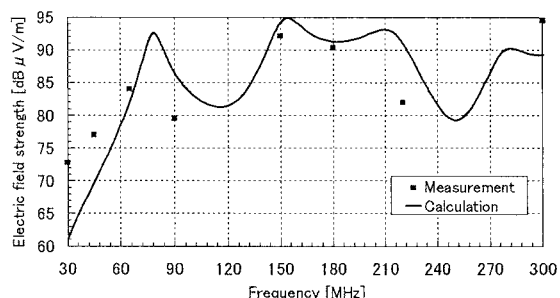

(b) Front face (receiving antenna height of 220cm)

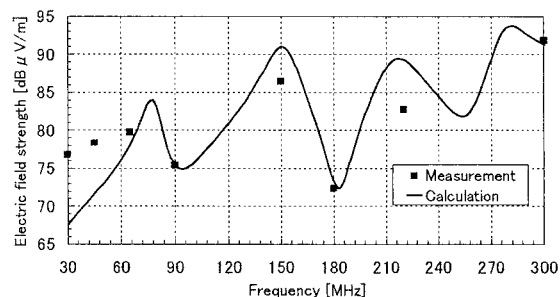

(c) Side face (receiving antenna height of 73cm)

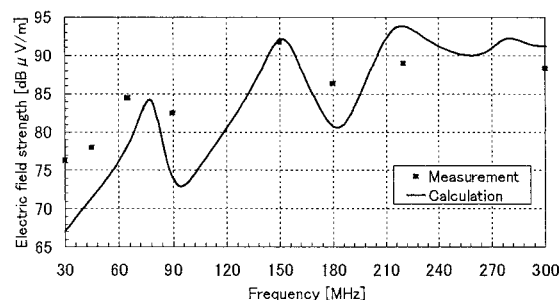

(d) Upper edge (receiving antenna height of 220cm)

Figure 3. Electric field strength of own loop antenna  
 Calculated values do not agree so well with measured values, and variation of calculated values to the frequency is steeper than that of measured values. As this reason, it is considered that the measured value is average value of electric field strength in the volume of the receiving antenna but the calculated value is electric field strength at the point set on the receiving antenna. However, tendency between the calculated and measured values is almost the same each other, and then it is

considered that the calculation model to the impression method of terminus conditions and voltage for a balun as shown in Fig.2 is appropriate. Therefore, we decided to use this calculation model as a model of a balun for the solar cell.

5. Electric field characteristics of the solar cell

The measured and calculated frequency characteristics about electric field strength from the solar cell are shown in Fig.4. We measured 4 receiving antenna positions as almost the same as the loop antenna shown in Fig.3, but Fig.4(b) is the case of back face instead of the front face (receiving antenna height of 220cm) shown in Fig.3(b). Measured values are shown as square point, and solid line in Fig.4 is shown calculated values for the electric conductivity of  $2.53 \times 10^3 \text{ S/m}$ . In addition, calculated value for the electric conductivity of copper  $5.8 \times 10^7 \text{ S/m}$  is shown with dashed line in Fig.4 for comparison.

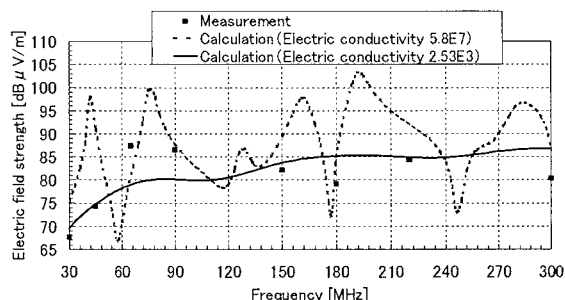

(a) Front face (receiving antenna height of 73cm)

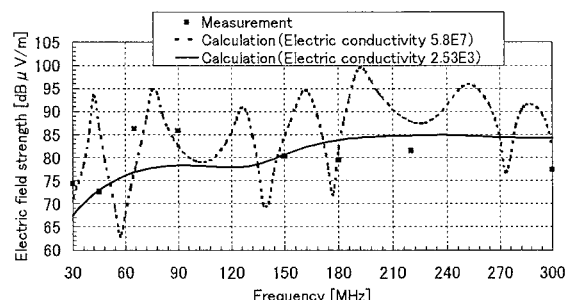

(b) Back face (receiving antenna height of 73cm)

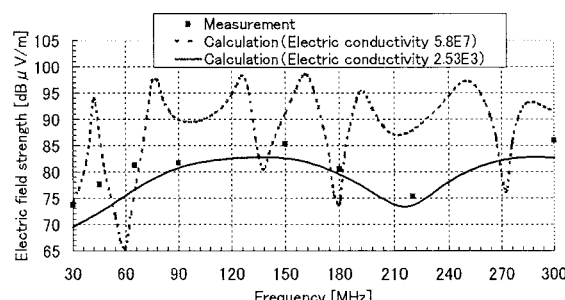

(c) Side face (receiving antenna height of 73cm)

## 3D3-2

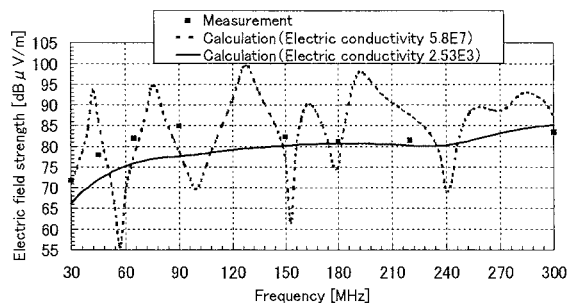

(d) Upper edge (receiving antenna height of 220cm)

Figure 4. Electric field strength of solar cell

The measured values does not so depend to the position of receiving antenna as shown in Fig.4(a) to Fig.4(d), especially the measured values to the back face is almost the same as that to the front face. The maximum measured value of electric field strength is about 85dB  $\mu$  V/m when a input voltage of the solar cell with the balun is 0.7V, and then it is necessary to decrease the input voltage to several mV or less if the radiated electric field strength from the solar cell have to be complied with that specified by VCCI (Voluntary Control Council for Interference by Information Technology Equipment), 40dB  $\mu$  V/m at the distance of 3m between EUT and the receiving antenna. Moreover, we calculated the electric field strength from the outline pattern of the solar cell as shown in Fig.2(b) because we could not obtain accurate information about the wiring pattern inside the solar cell from the maker. Therefore, a wiring pattern inside the solar cell should be measured precisely, and the high frequency characteristics for the input impedance of the solar cell should also be cleared in future.

The calculated values for the electric conductivity of copper  $5.8 \times 10^7$  S/m vary steeply to the frequency for all position of the receiving antenna, but the calculated values for all position of the receiving antenna can be fit each other to measured values by using the electric conductivity of  $2.53 \times 10^3$  S/m.

### 5. Conclusion

Radiated electromagnetic field from the solar cell is studied experimentally and theoretically in order to clear antenna effect of the solar cell. As the result, it is clear as follows;

- (1) The radiated electromagnetic field of own made loop antenna was measured, and compared with calculated value in order to obtain the model of balun that is necessary for the measurement of the radiated electromagnetic field. As a result, it is conformed that the model of balun is almost appropriate.
- (2) Solar cell was modeled by the conductor with limited resistance, and electric field strength

radiated from the solar cell was computed by the method of moment. As a result, the calculated values for all position of the receiving antenna can be fit each other to measured values by using the electric conductivity of  $2.53 \times 10^3$  S/m.

### References

- [1] A. Tsutsumi, K. Harata, Y. Isihara, and T. Todaka, "A study of the radiation noise from PV modules," Japan solar energy society / Japanese style power energy association combination study announcement meeting lecture article collection, vol.1999, pp. 395-398, Nov. 1999. (in Japanese)
- [2] H. Igarashi and S. Suenaga: "Characteristics of electromagnetic environment of PV generating system," Technical Report of IEICE, EMCJ2003-64, pp.59-65, 2003. (in Japanese)