

BROADBAND MILLIMETER-WAVE MICROSTRIP LINE TO WAVEGUIDE TRANSITION

Yusuke DEGUCHI, Kunio SAKAKIBARA
Nobuyoshi KIKUMA and Hiroshi HIRAYAMA
Nagoya Institute of Technology
Gokiso-cho, Showa-ku, Nagoya, 466-8555, Japan
E-mail deguchi@luna.elcom.nitech.ac.jp

1 Introduction

Millimeter-wave antennas have been developed for applications of broadband high-speed wireless communication systems and automotive radar systems in these days. Microstrip antennas (MSA) are more advantageous than other millimeter-wave antennas at the viewpoints of low-profile and low-cost. The antenna is connected to the backed RF circuits through the waveguide in the millimeter-wave module as is shown in Fig.1. Therefore, microstrip line (MSL) to waveguide transition (MSL-WG transition) is required at the connection of the waveguide and the antenna feed[1][2].

We propose a novel MSL-WG transition which covers more than 25% frequency bandwidth for the uses of broadband applications and wide tolerance in manufacturing. We designed the MSL-WG transition by using an electromagnetic simulator. Performance and applicability are confirmed by measurement in the millimeter-wave band.

2 Structure of the proposed transition

The MSL-WG transition connects a waveguide in the metal plate and MSL of the antenna feed as shown in Fig.1. The MSL is perpendicular to the waveguide and the strip at one end of the MSL is inserted into the waveguide whose one end is short. The structure of the proposed transition is shown in Fig.2. The dielectric substrate with conductor patterns on both sides shown in Fig.2(b) and (c) is set on the open ended waveguide (WR-12, 3.1×1.55 mm). Moreover, the upper waveguide whose length is approximately $\lambda_g/4$ (λ_g :guide wavelength of the waveguide) is covered on the aperture of the dielectric substrate. Via holes surrounding the waveguide reduce leakage of parallel plate mode transmitting into the substrate. Figure 3 shows a photograph of the proposed transition. The upper waveguide is composed of metal plates. They are screwed on the substrate.

There are two distinctive features in the conductor patterns of BB' plane shown in Fig.2(b). First, the strip shifts d in y -direction from the center of the waveguide because the local impedance which is ratio of electric field and magnetic field at the strip in the waveguide is lower at $y = d$ rather than at the center of the waveguide ($y = 0$). Therefore, the impedance

becomes comparable with characteristic impedance of the MSL and impedance matching could be achieved by controlling the shift d of the strip from the center of the waveguide. Second feature is a ground extension into the waveguide as shown in Fig.2(b). The extended ground works as a capacitive obstacle which can control the reactance of the matching circuit[3].

3 Results of simulations and measurements

Major parameters indicated in Fig.2 are optimized at the design frequency 76.5 GHz by using an electromagnetic simulator of finite element method. Dielectric constant of the substrate is 2.2. As a result of the parameter optimization, length l of the strip inserted into the waveguide is 0.70 mm, distance s from the strip to the waveguide short is 0.50 mm, shift d of the strip from the center of the waveguide broad wall is 0.45 mm and length p of the extended ground is 0.50 mm.

Performance of the fabricated transition with the optimum parameters is evaluated by measurement in the millimeter-wave band. Figure 4 shows reflection S_{11} and transmission S_{21} of the proposed transition. Low insertion loss is achieved such that measured insertion loss is 0.35 dB at 76.5 GHz. It is 0.11 dB larger than simulation. Moreover, two resonances are observed and broadband characteristic is obtained such that bandwidth for reflection below -20 dB is 19.4 GHz (25.3%). On the other hand, both resonant frequencies shift by approximately 3 GHz lower than that of simulation and the frequency band of -20 dB shifts by only 1 GHz. Loss increasing due to the frequency shift is quite small because this transition works well in broad frequency bandwidth.

In order to clarify the reason for the double resonance for the broad bandwidth, the effect of the two geometrical features d and p are investigated by simulation. Figure 5 shows simulated resonant frequency versus d . Only one resonant frequency is observed when d is smaller than 0.38 mm. However, two resonant frequencies appear between $d = 0.38$ mm and 0.49 mm. Due to the double resonance, broadband impedance matching is achieved between the waveguide and the MSL. Next, we investigate the effect of ground extension p . Figure 6 shows frequency dependency of scattering coefficients of S_{11} and S_{21} of transition optimized without ground extension ($p = 0$). Insertion loss 0.22 dB is similar level to the simulated loss of the transition with the ground extension. However, bandwidth of the reflection below -20 dB is 15.3 GHz (20.0%) and is narrower than that with the ground extension because of the single resonance. Therefore, both ground extension p and strip shift d cause the double resonance and the broadband characteristic.

4 Conclusion

We have proposed the novel MSL-WG transition in the millimeter-wave band. As a result of the measurements, broadband characteristics is confirmed such that bandwidth of the reflection below -20 dB is 19.4 GHz (25.3%).

References

- [1] H.Iizuka, T.Watababe, K.Sato and K.Nishikawa, "Millimeter Wave Microstrip Line to Waveguide Transition Fabricated on a Single Layer Dielectric Substrate," IEICE Trans. Commun., Vol.E85-B, pp.1169-1177, June 2002
- [2] K.Sakakibara, Fuminori Saito, Yuta Yamamoto, Naoki Inagaki and Nobuyoshi Kikuma, "Microstrip Line to Waveguide Transition Connecting Antenna and Backed RF Circuits," 2003 IEEE APS. Dig. Vol.3, pp.958-961, Ohio, USA, June 2003.
- [3] N.Marcuvitz, Waveguide Handbook, IEE Electromagnetic Waves Series 21, Peter Peregrinus Ltd., 1993

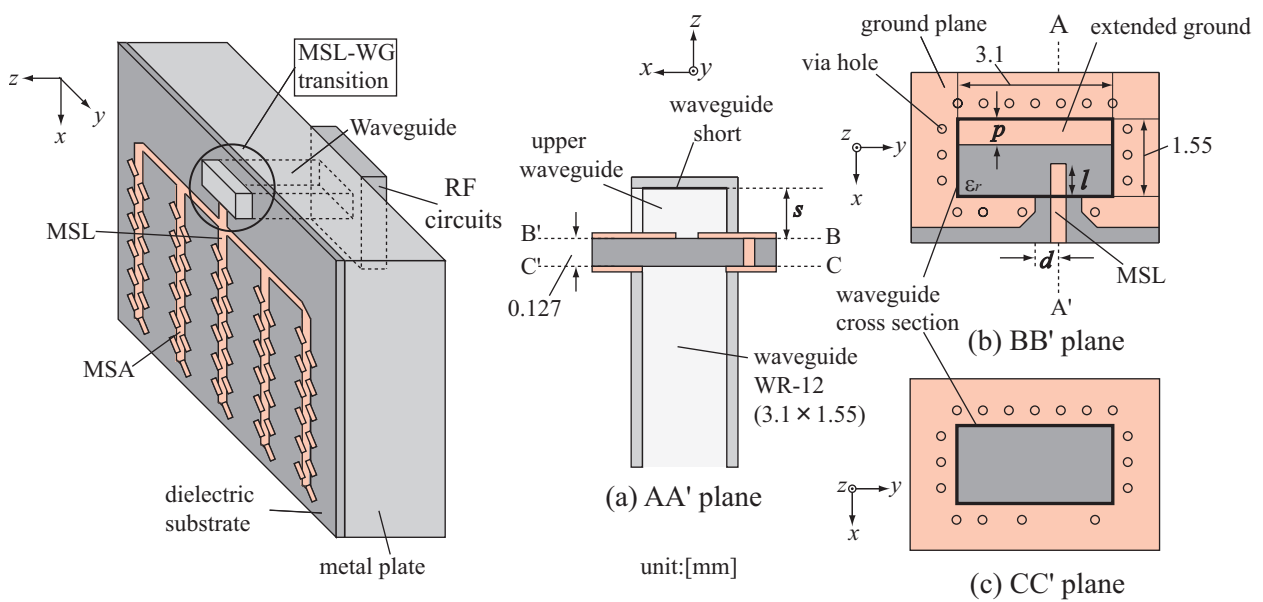

Fig.1 Millimeter-wave module

Fig.2 Structure of the proposed transition

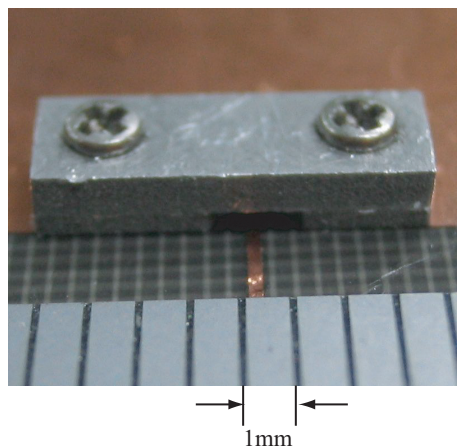

Fig.3 Photograph of the proposed transition

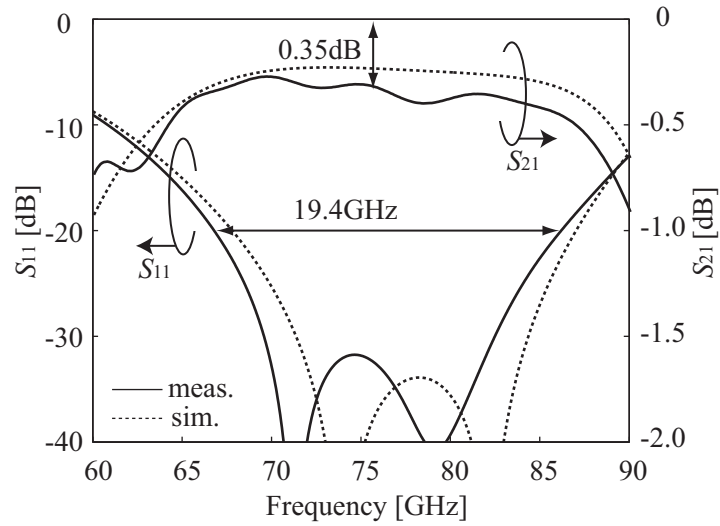

Fig.4 Measured and simulated S_{11} and S_{21} of the MSL-WG transition

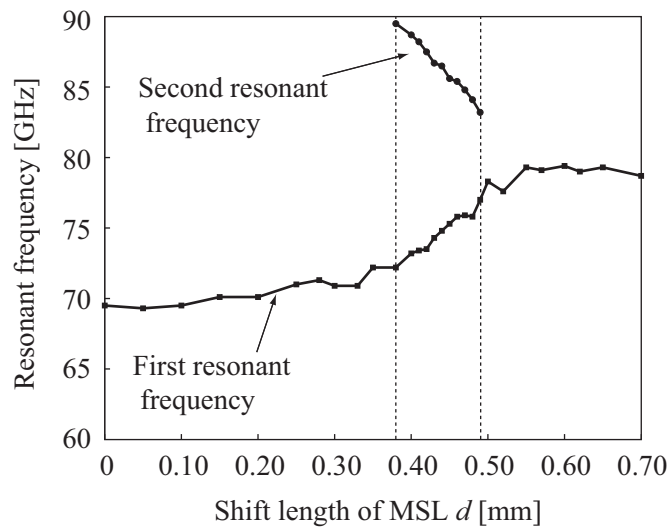

Fig.5 Simulated resonant frequency versus shift length of MSL d

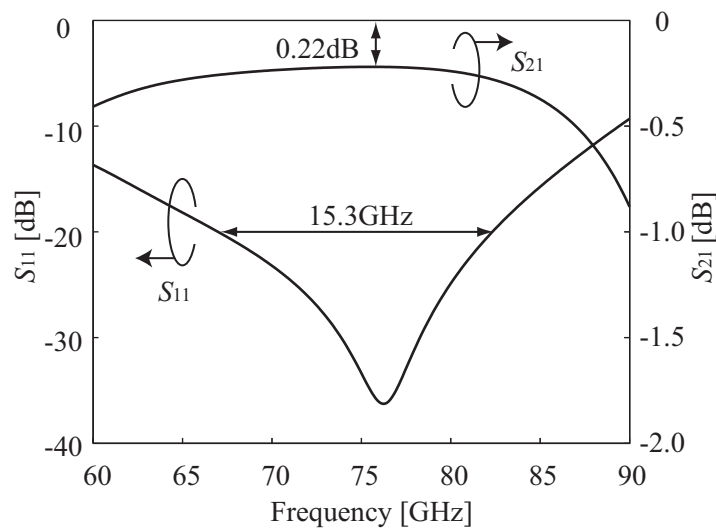

Fig.6 Simulated S_{11} and S_{21} of the MSL-WG transition without ground extension