

EVALUATION OF CONDUCTIVITY AND COMPLEX PERMITTIVITY OF A COPPER-CLAD DIELECTRIC SUBSTRATE BY USING A WHISPERING GALLERY MODE RESONATOR

Tran Thi Huong¹, Takafumi Kai¹, Jiro Hirokawa¹, Yoshinori Kogami² and Makoto Ando¹

¹Department of Electrical and Electronic Engineering, Tokyo Institute of Technology
S3-19, 2-12-1, O-okayama, Meguro-ku, Tokyo, 152-8552, JAPAN

E-mail: tranhuong@antenna.ee.titech.ac.jp

² Department of Electrical and Electronic Engineering, Utsunomiya University
7-1-2, Yoto, Utsunomiya, Tochigi, 321-8585, JAPAN

E-mail: kogami@cc.utsunomiya-u.ac.jp

1. Introduction

A millimeter wave band measurement technique using a small metal cavity is proposed for precise evaluation of complex permittivity of a dielectric substrate [1] and the conductivity of a copper-clad dielectric substrate [2]. Another method using an open type Whispering Gallery (WG) mode dielectric resonator has been proposed to measure complex permittivity of a dielectric substrate [3]-[6]. In the method, the diameter of the resonator is about 20 - 30 times the wavelength and the thickness is nearly equal to the wavelength. It is easy to make the resonator accurately and the manufacturing error is not sensitive to the measurement result well. A WG mode is a higher order resonance mode propagating to the circumferential direction along the edge of a dielectric disk. The dielectric property in a wide frequency range can be obtained for only one sample by using several WG modes which appear periodically. The resonator has very little radiation loss and does not need any shielding structure.

The authors have developed and demonstrated a post-wall waveguide-fed parallel-plate slot array antenna in millimeter-wave band using a copper-clad dielectric substrate [7, 8]. A post-wall waveguide in the antenna consists of densely arrayed metalized via-holes. The waveguide is a closed waveguide free of radiation loss and the losses mainly come from both dielectric and conductor losses. A precise dielectric constant should be included in the design of the antenna in millimeter wave band. A lack of precise estimation of the electric properties and the losses of material limits the performance of the antenna so far.

In this paper, we evaluate accurately the conductivity as well as the complex permittivity of a copper-clad dielectric substrate in millimeter wave region. The roughness of the boundary between copper and dielectric for the mechanical contact could degrade the conductivity of the copper equivalently, which results in increase of loss. We first conduct the evaluation of complex permittivity in a dielectric substrate without copper by using the open type WG mode resonator. Then we estimate the conductivity of rolled copper of the substrate based upon the obtained complex permittivity by using the copper-clad type WG mode resonator.

2. Whispering Gallery Mode Resonator and Measurement Method

Fig.1(a) shows the structure of a Whispering Gallery mode resonator used in the measurement. The circular disk is made of a dielectric substrate material under test. The WG mode is excited by a rectangular dielectric waveguide and propagates along circumference of the disk, and then is detected by another waveguide.

Fig.1(b) and (c) present the desirable polarization of field of WGH mode appeared in the circular disk and the position of the waveguide. In order to excite the desirable WGH mode, the waveguides should be located near the side of the circular disk for the copper-clad dielectric resonator while they are located under the circular disk for the open one. We adjust the distance between the resonator and the waveguides carefully to detect a proper power of the mode to get the accurate unload Q [5].

The measurement system is shown in Fig.2. The WG mode resonances can be arisen periodically in order of the circumferential mode number in a wide frequency band by the appropriate experiment.

The resonant frequencies and unload Q can be evaluated from the resonant response [5].

A PTFE substrate reinforced fiberglass is used as sample substrate material. Three WG mode resonators are made from this PTFE substrate:

Disk 1: Open type WG mode resonator disk, diameter $d=59.8$ [mm], thickness $t=3.18$ [mm]

Disk 2: Open type WG mode resonator disk, diameter $d=62.0$ [mm], thickness $t=3.18$ [mm]

Disk 3: Copper-clad type WG mode resonator disk, diameter $d=54.96$ [mm], thickness $t=0.8$ [mm]

3. Permittivity and Loss Tangent measurement by using Mode Matching Method

The open type WG mode resonator is analyzed with Mode Matching Method [5]. The complex dielectric constant can be calculated accurately from the resonant frequency and unload Q [6]. The open type WG mode resonator- Disk 1, Disk 2- are used to measure the complex dielectric constant (permittivity and loss tangent).

Figs. 3 and 4 present the measurement result of these open type WG mode resonators. In Fig.3, the two resonators have almost the equal value of unload Q at the same frequency region. Actually, there are small errors in unload Q, which will make undesirable ripples in the result of permittivity and loss tangent as shown in Fig.4.

Fig.4 shows the frequency characteristic of permittivity and loss tangent result in high precision. The permittivity of this PTFE substrate material decreases while the loss tangent increases with increasing of frequency. The permittivity ϵ_r shifts from 2.160 to 2.155 in a range of 70GHz - 110GHz for both disks. The loss tangent $\tan\delta$ varies 0.0007 - 0.0086 in the range.

4. Estimation of Conductivity

The copper-clad type WG mode resonator is used in order to estimate the conductivity of the rolled copper with the both surfaces. We use an electromagnetic field simulator based on FEM "Ansoft HFSS" for the analysis of the resonator. The full structure of the resonator is presented in Fig. 5. The resonator is so large in term of wavelength for analysis that it is necessary to reduce the analysis region by considering the periodicity and the intensity distribution of the excited field. The field pattern of a standing wave in the resonator appears periodic along the circumference of the disk, so that the analysis model can be extracted by setting perfect magnetic conductors at two boundaries where the electric field is the maximum. Furthermore, it can be reduced by taking off the center part of the resonator where the field is very weak. A perfect electronic conductor is placed at the middle of the height.

After the size reduction of the analysis model, the HFSS is used to calculate the unload Q of this copper-clad WG mode resonator. The result of the complex permittivity of the open type resonator without copper is used. The only unknown factor is the conductivity of the copper.

Fig.7 presents the measured unload Q of a copper-clad WG mode resonator, Disk 3. We use the permittivity of 2.159 and the loss tangent of 0.0074 obtained from Fig.4. The two horizontal lines of Fig.8 at 816.45 and 816.79 correspond the measured unload Q at 76.864GHz for the mode number 60 and 79.332GHz for the mode number 62. The two curves with marks in Fig.8 shows the unloaded Q as functions of the conductivity, which are calculated by HFSS. The estimated conductivity are 3.6×10^7 and 3.9×10^7 [1/Ohm-m] for the mode numbers 60 and 62, respectively. The measurement errors appear due to the difficulty of the excitation of the disk.

5. Conclusion

We have evaluated conductivity and complex dielectric constant of a copper-clad substrate using Whisper Gallery mode resonator system. The dielectric constant and the loss tangent $\tan\delta$ of a glass fiber reinforced dielectric substrate are $\epsilon_r = 2.157 \pm 0.003$ and $\tan\delta = 7.5 \pm 0.5 \times 10^{-4}$. The conductivity of the copper rolled on the both surfaces is $3.6 \times 10^7 - 3.9 \times 10^7$ [1/Ohm-m]. The method of the excitation of the disk should be improved for more precise measurements.

References

- [1] T. Shimizu, Y. Kobayashi, T. Kasashima and K. Ohbayashi, "simple permittivity measurements by the cut-off waveguide method using 80GHz cavities", 2004 spring Natl. Conv. Rec. IEICE, C-2-83, Mar.2004.
- [2] R. Takaichi, T. Aoki and Y. Kobayashi, "Back-side Relative Conductivity Measurements of Three Types of Copper-clad Dielectric Substrates", 2004 spring Natl. Conv. Rec. IEICE, C-2-125, Mar.2004.
- [3] Y. Tomabechi and K. Matsumura, "Resonance characteristics of whispering gallery modes on a dielectric resonator", IEEE Trans.vol.J75-C-I, no.11, pp.687-693, Nov.1992
- [4] Y. Kogami and K. Matsumura, "Characterization of low-permittivity dielectric materials in millimeter wave region using whispering gallery mode resonator", IEICE Trans, vol.J83-C, no.6, pp.553-658, June 2000
- [5] Y. Tomabechi, Y. Kogami, M. Matsubara and K. Matsumura, "An Analysis for the Whispering Gallery Modes on a Millimeter Wave Dielectric Disk Resonator by a Point Matching Method", IEICE Trans. Electron., vol.E84-C, no.10, pp.1554-1560, Oct 2001
- [6] H. Tamura, Y. Kogami and K. Matsumura, "Improvement of the Relative Permittivity Evaluation with a Whispering-Gallery Mode Dielectric Resonator Method", IEICE Trans. Electron., vol. 86-C, no.8, pp.1665-1671, Aug 2003
- [7] J.Hirokawa and M.Ando, "Single-Layer Feed Waveguide Consisting of Posts for Plane TEM Wave Excitation in Parallel Plates", IEEE Trans. Antennas & Propagat., vol.46, no.5, pp.625-630, May 1998.
- [8] J.Hirokawa and M.Ando, "Efficiency of 76-GHz Post-Wall Waveguide-Fed Parallel-Plate Slot Arrays", IEEE Trans. Antennas & Propagat., vol.48, no.11, pp.1742-1745, Nov. 2000.

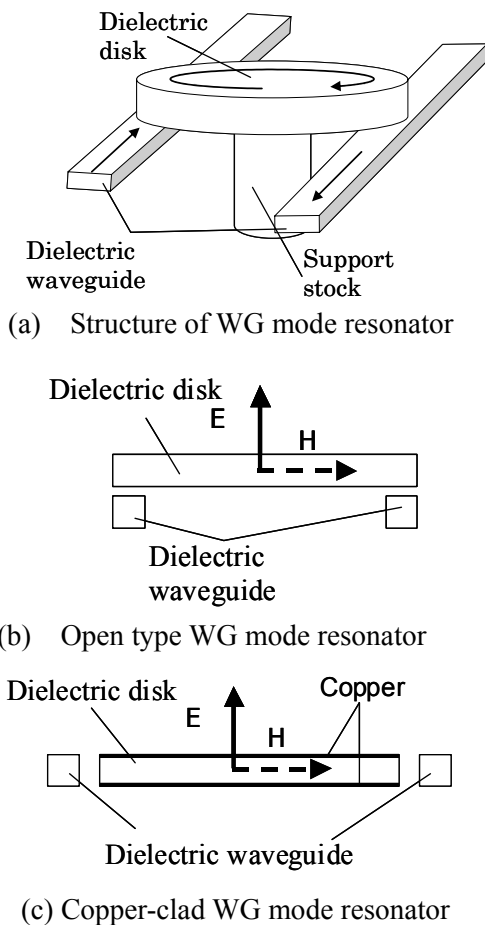

Fig1: A structure of WG Mode Resonator for permittivity measurement

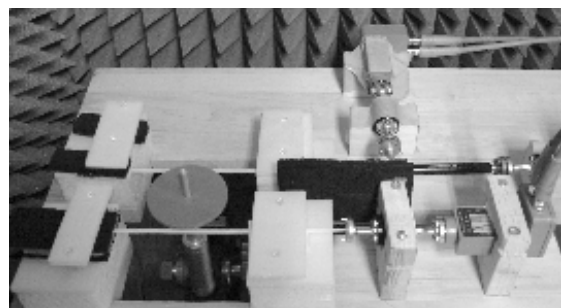
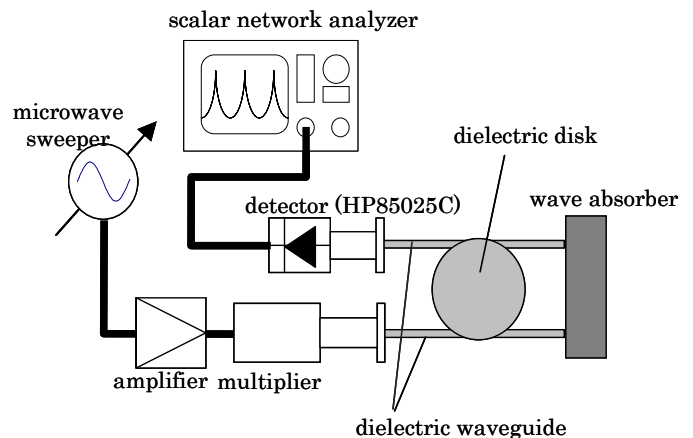

Fig2: Measurement system

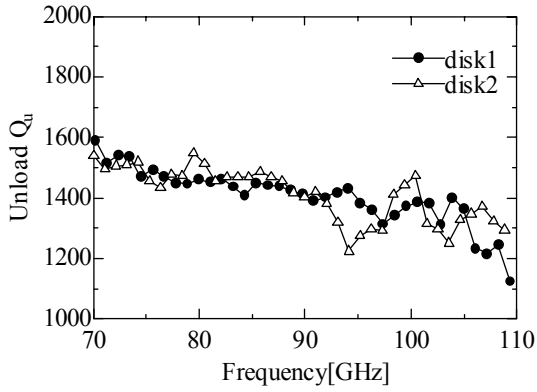

Fig3: The frequency characteristic of Unload Q_u

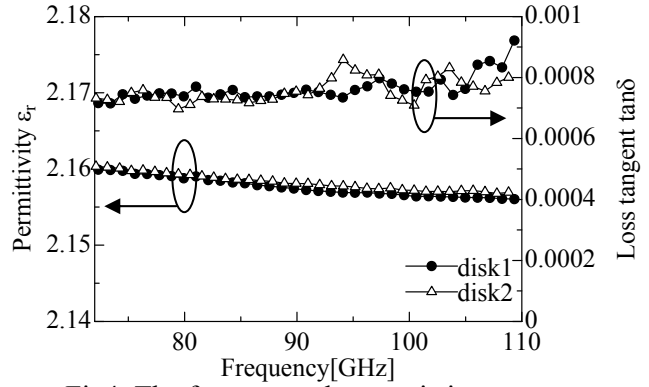

Fig4: The frequency characteristic of permittivity and Loss tangent

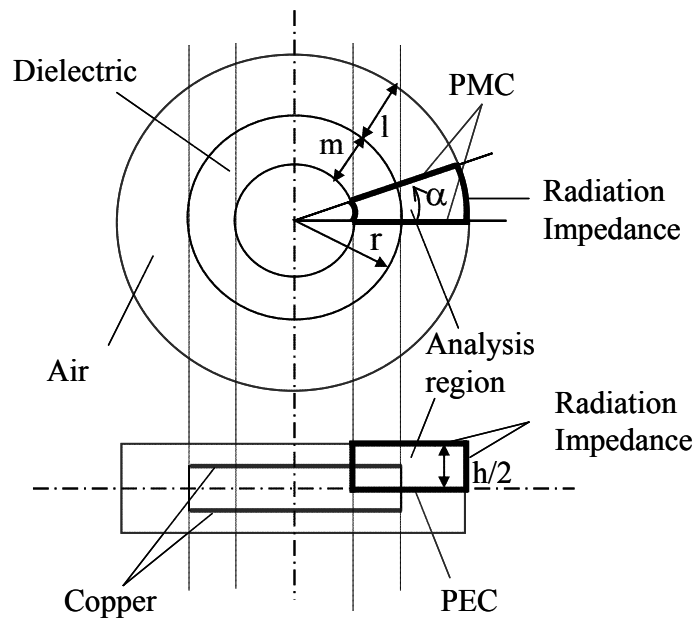

Fig5: The analysis mode of copper-clad WG mode resonator

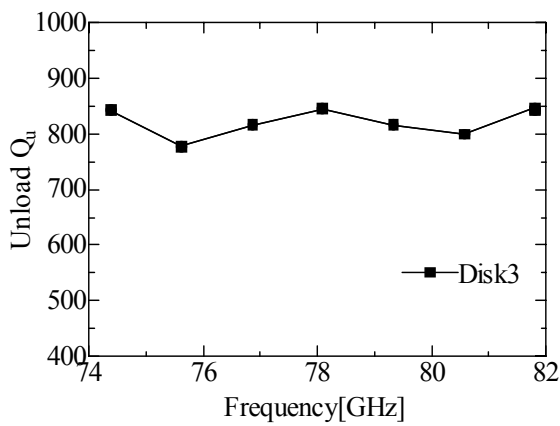

Fig6: The frequency characteristic of unload Q_u

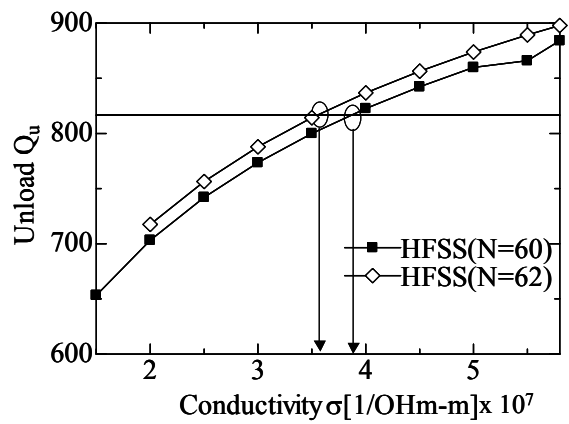

Fig7: The frequency characteristic of unload Q_u