

AUTOMATIC CALIBRATION METHOD OF ADAPTIVE ARRAY CONSIDERING ANTENNA CHARACTERISTICS FOR FDD SYSTEMS

Kentaro Nishimori, Keizo Cho, Yasushi Takatori, and Toshikazu Hori
Nippon Telegraph and Telephone Corporation
1-1 Hikarinooka, Yokosuka, Kanagawa, 239-0847 Japan
E-mail: nisimori@wslab.ntt.co.jp

1. Introduction

It is well-known that adaptive arrays can effectively suppress co-channel and inter-symbol interference and improve system performance [1]. Since the radiation pattern of the adaptive array is generally formed on the baseband by means of Digital Beam Forming (DBF) [2], the amplitude and phase errors must be calibrated between the branches of the array because of individual differences in the RF devices of the receivers and transmitters [3]. Moreover, since these errors change over time due to temperature variations [4], real-time calibration is required.

We proposed an automatic calibration method using a transmitting signal (ACT) for the transceiver of an adaptive array [4]. This method can remove an additional signal generator for calibration by circulating the transmitting signal to the receivers while achieving real-time calibration. However, calibrating the antennas and cables is also required for Frequency Division Duplex (FDD) systems, which are commonly used in cellular systems [5], because the frequency of the transmitted signal is different from the received signal.

This paper proposes an automatic calibration method for the adaptive array that considers the characteristics of the antenna and cable for FDD systems. The effectiveness of the proposed calibration method is evaluated by measurements using an adaptive array testbed. In this paper, first the required calibration for FDD systems is clarified. Then the proposed calibration method is described. Finally, the measurement results are presented.

2. Required calibration for FDD systems

Figure 1 shows the configuration of an ordinary DBF adaptive array for FDD systems. The adaptive array for TDD systems requires calibration of the transceiver part because the influence of mutual coupling between antenna elements and the cable is the same for both the transmitting and receiving cases, and is cancelled out [4]. On the other hand, since the transmitting frequency is different from the receiving frequency for FDD systems, the calibration of not only the transceiver part but also the antenna and the cable is required. In particular, the amplitude ratios and phase differences between antennas also change due to mutual coupling and influence from the surrounding environment. Furthermore, phase differences between the cables connecting the antennas and transceivers arise because the expansion and contraction characteristics of the cables before the base station is established and those after it is established are different. However, it is difficult to measure the various influences before the base station is established because these influences largely depend on the circumstances surrounding the establishment. Therefore, calibration that includes the antennas and cables is required after the establishment of the base station.

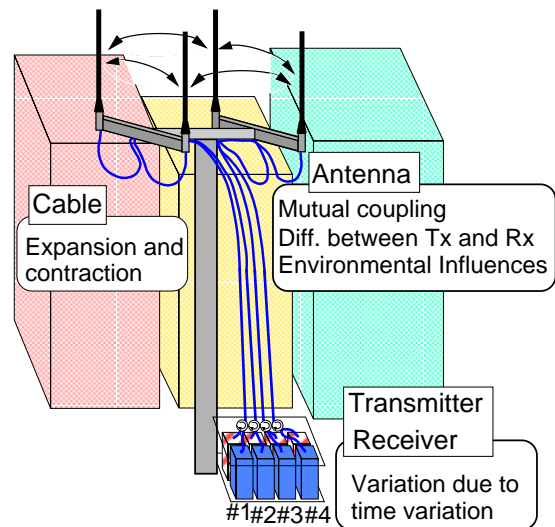

Fig. 1 Configuration of ordinary DBF adaptive array for FDD systems

3. Proposed calibration method

Figure 2 shows a configuration of the proposed calibration method for the FDD systems. The proposed configuration has several features. First, an additional antenna is placed such that it can transmit and receive signals between the array antenna elements. Circulator 2 (C2) is connected to the additional antenna and takes input signals at the transmitter frequency, f_1 , and outputs the signal at the receiving frequency, f_2 . Moreover, Frequency converters 1 (FC1) and 2 (FC2) that convert a signal of f_1 to a signal of f_2 are placed below C2, and FC1 and FC2 are connected to Transmitter 1 (Tx1) and receiver 1 (Rx1), respectively. The detail procedure of the proposed calibration is described hereafter.

Figure 3 shows the calibration procedure for the transmitter and transmission antenna. First, the signal for Antenna #1 is transmitted through Transmitter 1 (Tx1) and Circulator 1 (C1). This signal is received at the additional antenna and is input through C2. Then, this signal is converted to receive signal frequency f_2 using FC2 because the frequency of this signal is the transmitting frequency, f_1 . This converted signal is finally output to Receiver 1 (Rx1) through the switch (SW). The value K_1 , which is obtained from the loop of Branch #1 is expressed as

$$K_1 = T_1 M_1(f_1) L_{1a} M_a(f_1) Q_2 R_1 \quad (1)$$

where $M(f_i)$, T , and R represent the complex transmission function of the transmitting antenna, transmitter and receiver, respectively, Q_2 represents the complex transmission function of FC2, and L represents the propagation loss. Similarly, the value K_i , which is obtained from the loop of Branch # i is expressed as

$$K_i = T_i M_i(f_1) L_{ia} M_a(f_1) Q_2 R_i \quad (2)$$

Here, the calibration value $H_{i,1}$ for the i -th branch relative to the first branch can be obtained as

$$H_{i,1} = \{T_i M_i(f_1)\} / \{T_1 M_1(f_1)\} \quad (3)$$

Using Equations (1) and (2), the following equation is given by

$$\begin{aligned} K_i/K_1 &= \{T_i M_i(f_1) L_{ia} M_a(f_1) Q_2 R_i\} / \\ &\quad \{T_1 M_1(f_1) L_{1a} M_a(f_1) Q_2 R_1\} \\ &= \{T_i M_i(f_1) L_{ia}\} / \{T_1 M_1(f_1) L_{1a}\} \quad (4) \end{aligned}$$

As can be seen in Equation (4), since FC2, Rx1, and the additional antenna are commonly used for this calibration, the influence of those characteristics are canceled out. Therefore, L_{ia} must be equal to L_{1a} to satisfy the relationship in which Equation (3) is equal to Equation (4). To realize this on the proposed calibration, the additional antenna is placed such that the distance between the additional antenna and Antennas #1 and # i are equal to each other. For example, the additional antenna is placed at the center of the array in a circular array or in the middle between antennas in the linear array. Consequently, the calibration values for the transmitter and transmitting antenna are obtained by using Equation (4).

The calibration for the receiver and receiving antenna can be obtained by using a procedure similar to the transmission case. First, the signal from Tx1 is divided by the directional coupler (DC) and this signal is converted into a signal of f_2 using FC1 to transmit the signal of f_2 . This converted signal is next radiated on the additional antenna

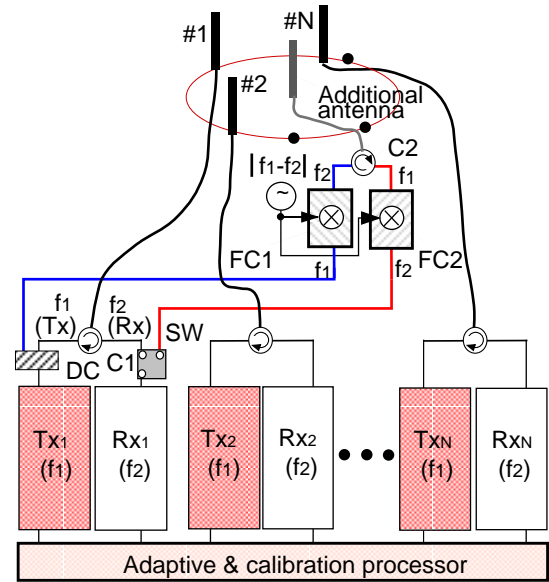

Fig. 2 Configuration of the proposed calibration method

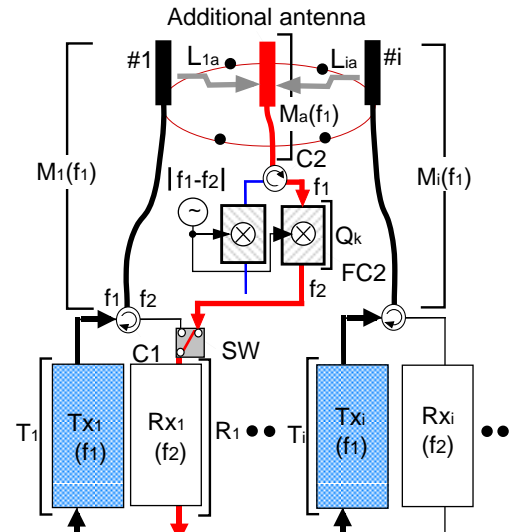

Fig. 3 Diagram of the proposed calibration for the transmitter and transmission antenna

through C2. Finally, this signal is received at Rx1 and Rx_i. The calibration value $S_{i,1}$ for the i -th branch relative to the first branch can be obtained as

$$\begin{aligned} S_{i,1} &= \{T_1 Q_1 M_a(f_2) L_{ai} M_i(f_2) R_i\} / \{T_1 Q_1 M_a(f_2) L_{a1} M_1(f_2) R_1\} \\ &= \{M_i(f_2) R_i / M_1(f_2) R_1\} \end{aligned} \quad (5)$$

where $M(f_2)$ is the complex transmission function of the receiving antenna and Q_1 represents the complex transmission function of the frequency converter (FC1). As Equation (5) shows, since Tx1, FC1, and the additional antenna are commonly used for this calibration, the influences of those characteristics are canceled out. Furthermore, the additional antenna is placed such that L_{ai} is equal to L_{a1} for this case. As a result, this calibration method achieves an automatic calibration that includes the antennas and cables without using the far field information.

4. Effectiveness of the proposed calibration method

To evaluate the calibration accuracy of the proposed calibration method in an actual propagation environment, we established the array antenna outdoors and measured the amplitude and phase errors between branches of an adaptive array testbed that we developed. The measuring environment is shown in Fig. 4. The transmission and reception frequencies of this testbed are 2.2 GHz and 1.9 GHz, respectively, and the number of branches is three. The height of the array is 2 m. The antenna array was a three element circular array and the radius of the array was 0.40 wavelengths. Sleeve antennas were used as the elements of the array. The additional antenna for the calibration was located at the center of the circular array.

Figure 5 shows the amplitude and phase errors of the receiver and antenna before and after calibration, respectively. These were captured over a three day period using the adaptive array testbed. The curves in Fig. 5 are the measured data of branches #2 and #3 relative to that of branch #1. As shown in Fig. 5, before calibration the amplitude and phase errors ranged from 0.5 to 1.5 dB and from 10 to 20 degrees, respectively. These errors were reduced to 0.15 dB and 1.8 degrees, respectively, by the proposed calibration method.

To evaluate the effectiveness of the transmission pattern using the proposed calibration method, the radiation pattern was measured using an adaptive array testbed in an anechoic chamber. Figure 6 shows the measurement environment. The broadside of the array was set to 0 degrees. When measuring the receiving pattern, a desired signal was transmitted from 0 degrees and an interfering signal with the same

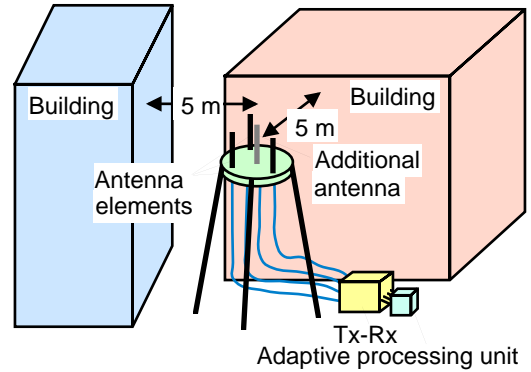

Fig. 4 Measurement environment for the calibration accuracy.

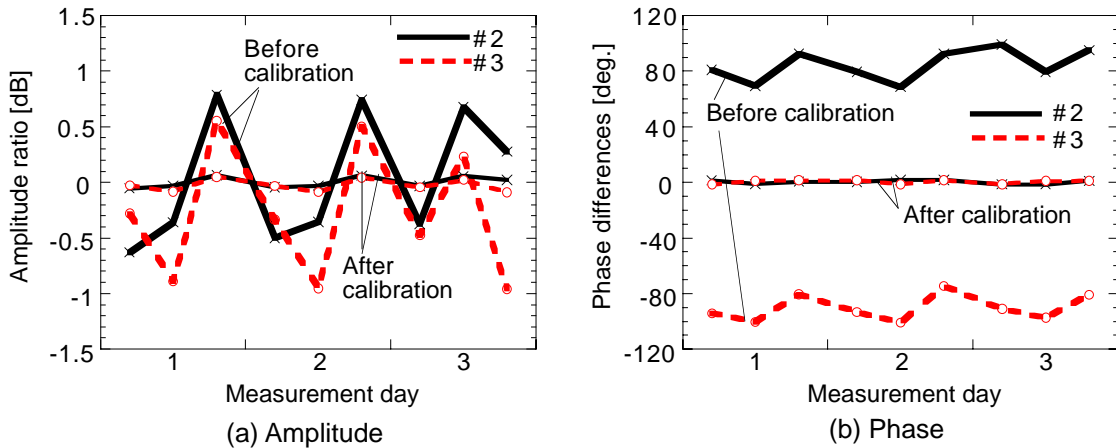

Fig. 5 Amplitude ratio and phase difference characteristics for the antenna and RF devices due to time variation

power was transmitted at 30 degrees. When measuring the transmitting pattern, signals weighted with the values calculated by the proposed calibration were input into the antenna array and were measured by horn antenna #3 shown in Fig. 6 while rotating the array. The receiving and transmitting frequencies were 1.9 and 2.2 GHz, respectively. In this paper, in order to compensate for the difference in the electrical length between the receiving and the transmitting frequencies, the phase factors, which enable the null direction in the transmission to coincide with the reception, are multiplied in the transmission mode.

Figure 7 shows the measured radiation pattern with the proposed calibration. The radiation pattern is also plotted in Fig. 7 when amplitude and phase errors originating from the antennas and cables are present. We used the measured amplitude and phase errors of the antennas and cables, respectively. As can be seen in Fig. 7, when these errors are present the output SIR falls 13 dB because the null direction disagrees with the direction of interference. On the other hand, when applying the proposed calibration, the null of the transmitting pattern coincides with the angle of the interference and the output SIR reaches 32 dB.

5. Conclusion

This paper proposed an automatic calibration method for the adaptive array that considers the characteristics of the antenna and cable for FDD systems. Measurements using an adaptive array testbed showed that the proposed calibration reduced amplitude and phase errors to 0.15 dB and 1.8 degrees, respectively in an actual propagation environment. Moreover, by measuring the radiation patterns in the presence of one interference signal, the proposed calibration method was found to ensure that the null of the transmitting pattern coincided with the angle of the interference.

Acknowledgment

The authors thank Dr. Hideki Mizuno of Nippon Telegraph and Telephone Corporation (NTT) for his constant encouragement.

References

- [1] J.H. Winter, "Smart antennas for wireless systems", IEEE Personal Commun. Mag., vol. 5, no. 1, pp. 23-27, Feb. 1998.
- [2] T. Ohgane, et al., "An implementation of a CMA adaptive array for high speed GMSK transmission in mobile communications," IEEE Trans. Veh. Technol., vol.42, no. 3, pp.282-288, March 1993.
- [3] G. Tsoulos, J. McGeehan, and M. Beach, "Space division multiple access (SDMA) field trials. Part 2: Calibration and Linearity issues", IEE Proc. Radar, Sonar Navig., vol.145, no. 1, pp.79-84, Feb. 1998.
- [4] K. Nishimori, K. Cho, Y. Takatori, and T. Hori, "A new calibration method of adaptive array for TDD systems," IEEE AP-S digest, pp. 1444-1447, July 1999.
- [5] Special issue, IMT2000: Standard Efforts of the ITU. IEEE Personal Commun., vol. 4, Aug. 1997.

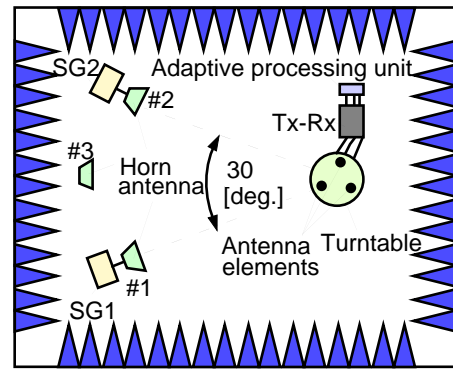

Fig. 6 Measurement environment for the radiation pattern

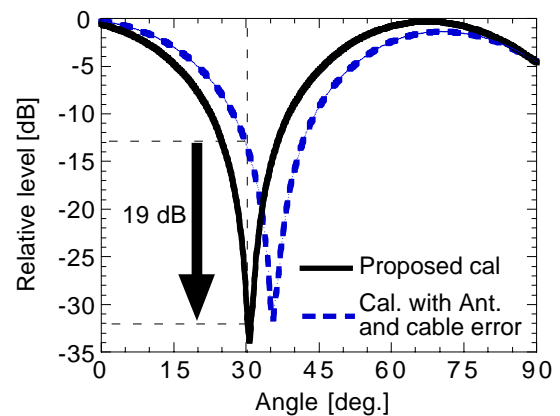

Fig. 7 Radiation pattern comparison