

PROCEEDINGS OF ISAP '92, SAPPORO, JAPAN

RADIATION PROPERTIES OF CIRCULARLY POLARIZED MICROSTRIP RING ANTENNA EXCITED BY DOMINANT MODE

T.TSUTSUMI, S.TSUDA, A.MATSUI and M.HANEISHI
Department of Electrical Engineering
Saitama University
Urawa-shi, Saitama 338, JAPAN

1. INTRODUCTION:

A microstrip ring antenna (R-MSA) system has been reported by several authors [1-2]. However, an R-MSA excited by a dominant mode (TM₁₁₀) has high impedance characteristics at the feeding point. Therefore, much attention has been paid to a circularly polarized R-MSA excited by a higher mode [3].

This paper presents new types of circularly polarized R-MSA (CP R-MSA) excited by a dominant mode. In order to evaluate the performance, some planar CP R-MSA's were fabricated and tested at the C-band. In this experiment, satisfactory results were obtained in both radiation patterns and impedance characteristics.

In this paper, basic designing techniques of the antennas are described together with some useful experimental results.

2. BASIC CONFIGURATION AND EQUIVALENT CIRCUIT OF CIRCULARLY POLARIZED R-MSA:

The structure of the CP R-MSA and its coordinate system employed here are shown in Fig.1. A CP R-MSA is categorized into two types by its feeding system: one is a directly coupled CP-wave antenna fed by a coaxial probe (Fig.1 (a)), and the other is an electromagnetically coupled one fed by a symmetrical cross-slot (Fig.1 (b)).

The equivalent circuit of this type of CP-wave antenna can be obtained using a perturbation technique applied to an ordinary microstrip antenna [4-5]. By application of network analysis to the equivalent circuit shown in Fig.2, the input impedance (Z_{in}) and the condition for CP-wave radiation can be determined analytically. In order to verify the validity of the CP-wave condition, a CP R-MSA fed by a coaxial probe was made and tested at the C-band. This antenna is made of a copper-clad 1.2mm Teflon fiberglass substrate having a dielectric constant of 2.55 and a loss tangent of approximately 0.0018.

The radiation pattern measured by a spinning dipole is shown in Fig.3. The axial ratio of the test antenna was less than 0.5 dB in the boresight direction. Moreover, the gain measured with a standard horn was about 6.8 dBi, and it was almost equivalent to the gain of an ordinary microstrip antenna. From these results, it was found that the equivalent circuit obtained by the perturbation technique is effective for designing of this type of antenna.

3. RADIATION PROPERTIES OF CIRCULARLY POLARIZED R-MSA FED BY SYMMETRICAL CROSS-SLOT:

In general, an R-MSA element excited by a dominant mode has high impedance characteristics at the feeding point F [1-3]. For this reason, impedance matching for the antenna is important for designing. In order to control such high impedance characteristics, a new type of CP R-MSA antenna, which is fed by a symmetrical cross-slot, is proposed here.

The basic configuration of the antenna is shown in Fig.4. As shown in the figure, the antenna is made of a two-layered Teflon fiberglass substrate. A radiating element having a perturbation segment (Δs) is printed on the surface of the upper layer. A symmetrical cross-slot having length of l_a and width of W_a is set in the ground plane of the antenna, and a microstrip feeding line is printed on the lower surface of the lower layer. Namely, the radiating element is coupled via a symmetrical cross-slot to the microstrip feeding line.

The measured input VSWR and resonant frequency of the antenna are shown in Fig.5 as a function of the slot-length (l_a) or open stub-length (l_s). These results indicate that the impedance matching of the antenna can be achieved by controlling the length of cross-slot (l_a) or the length of microstrip open stub (l_s).

Using these design charts, test CP R-MSA were made and tested at the C-band. In this case, the position of a feeding point F for the antenna is set at the center of the symmetrical cross-slot. Figure 6 shows the measured impedance characteristics of the typical CP-wave antenna. These results indicate that the impedance matching for the test antenna can be achieved by the selection of an appropriate feeding cross-slot. The optimum axial ratio was obtained at or near the peak of loop L in the impedance-locus.

Figure 7 shows a typical example of the measured axial ratio bandwidth for the CP-wave antenna. The axial ratio of the antenna was less than 0.5 dB at the designed frequency. The measured gain for the antenna is also shown in the figure. The gain at the designed frequency was about 6.5 dBi in this antenna, and it was almost equivalent to that of the CP-wave antenna fed by coaxial probe. These results show that the CP-wave antenna proposed here is considered to be applicable as a new type of circularly polarized planar antenna.

4. CONCLUSIONS:

The radiation properties of the circularly polarized R-MSA excited by a dominant mode were discussed in this paper. The experimental results confirmed high performance in both radiation patterns and the impedance characteristics within the desired frequency range. The antennas proposed here are, therefore, considered to be effectively applicable as new types of CP-wave planar antenna.

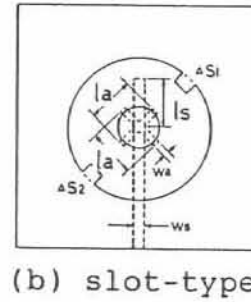
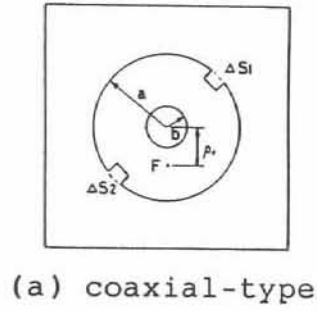
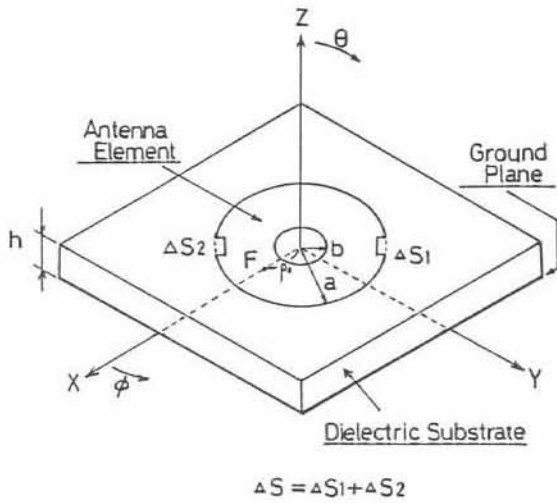
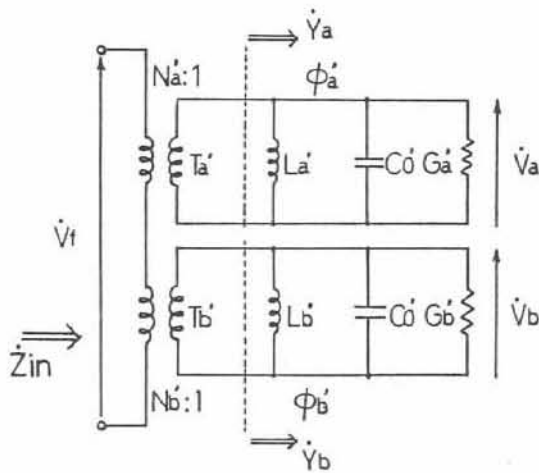

Fig.1 Basic configuration of test antennas.



$$f_{or} = \frac{\chi_{11} c}{2 \pi a \sqrt{\epsilon_r}} \quad \chi_{11} : \text{eigen value}$$

$$\frac{\Delta f_a'}{f_{or}} = \frac{b^2 \Delta \Delta S}{a^2 \Delta S} \quad \frac{\Delta f_b'}{f_{or}} = -\frac{\chi_{11} b^2 \Delta \Delta S}{a^2 \Delta S}$$

$$f_a' = f_{or} + \Delta f_a' \quad f_b' = f_{or} + \Delta f_b'$$

$$f_0' = \frac{1}{2} (f_a' + f_b')$$

$$N_a' = K \cos(\phi + 45^\circ) \quad N_b' = K \sin(\phi + 45^\circ)$$

$$K = \frac{\pi k^2 ab}{\sqrt{2}} \sqrt{A Y_1^2(\chi_{11})} \left[\frac{J_1(k\rho_a)}{Y_1(\chi_{11})} - \frac{J_1(\chi_{11})}{Y_1(k\rho_a)} \right]$$

$$A = \frac{(a^2 - b^2) Y_1^2(kb)}{a^2(1 - k^2 b^2) Y_1^2(ka) - b^2(1 - k^2 a^2) Y_1^2(kb)}$$

$$\dot{Y}_a = G_a + j\omega C_0 - \frac{1}{\omega L_a'} \quad \dot{Y}_b = G_b + j(\omega C_0 - \frac{1}{\omega L_b'})$$

$$\dot{Z}_{in} = \frac{N_a'^2}{\dot{Y}_a} + \frac{N_b'^2}{\dot{Y}_b}$$

condition on circular polarization

$$\left| \frac{\Delta S}{S} \right|_{Q_0} = \frac{1}{R^2 (\chi_{11}^2 + 1) A}$$

$$R = \frac{b}{a}$$

Fig.2 Equivalent circuit of test antenna.

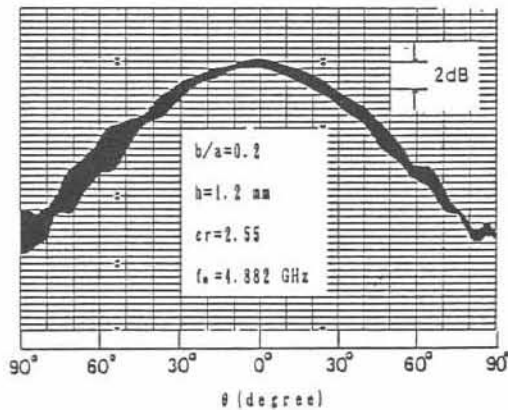

Fig.3 Typical pattern measured by spinning dipole.

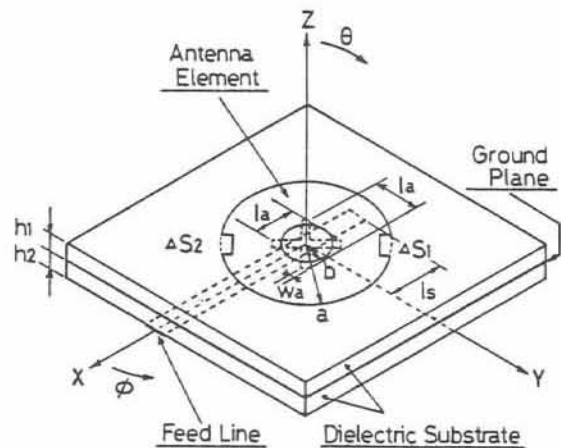

Fig.4 Basic configuration of R-MSA fed by symmetrical cross-slot

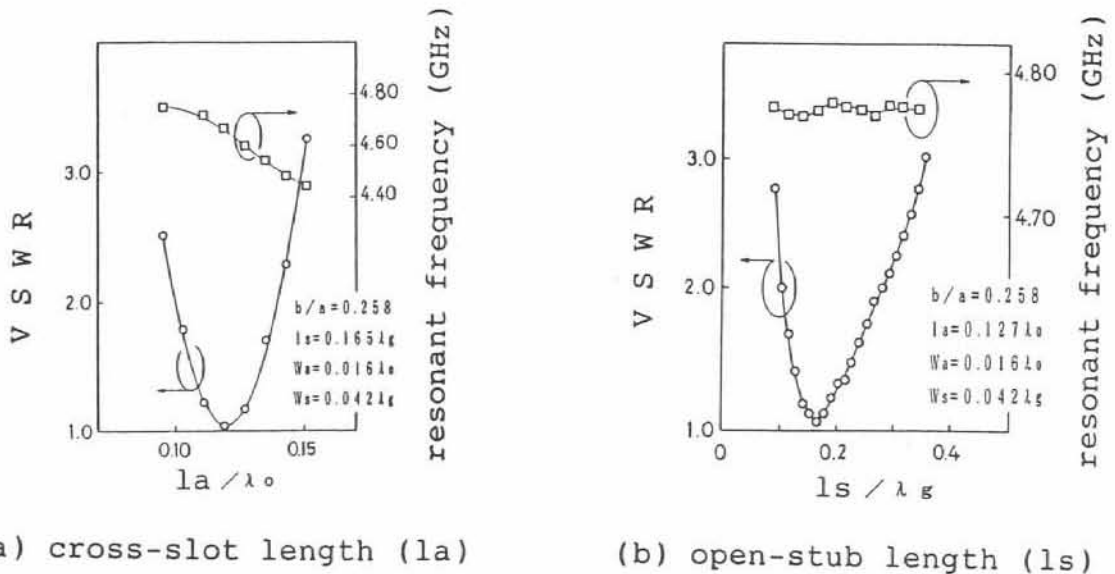

Fig.5 Input VSWR as a function of open-stub length or cross-slot length.

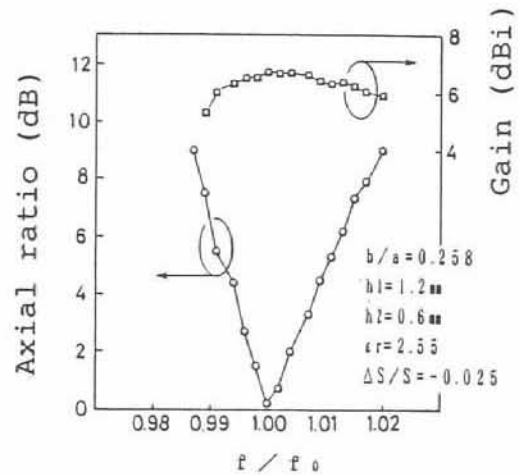
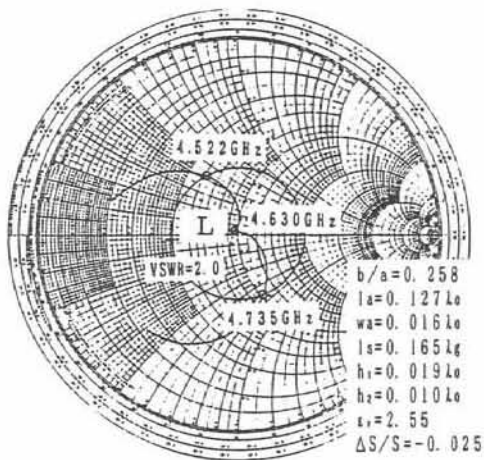

Fig.6 Impedance locus of R-MSA. Fig.7 Axial ratio and gain.

[REFERENCES]

- [1] I.J.Bahl, et.al: "A New Microstrip Radiator for Medical Applications", IEEE, MIT28, No.12, pp.1464-1468 (Dec.1980).
- [2] WENG CHO CHEW: "A Broad-Band Annular-Ring Microstrip Antenna", IEEE, Trans.AP-30, No.5, pp.918-922 (Sep.1982).
- [3] A.K.Bhattacharya, et.al: "Annular Ring as a Circularly Polarized Antenna", IEEE/APS'87, pp.1020-1023 (Jun.1987).
- [4] T.Tsutsumi, et.al: "Radiation Properties of Ring Microstrip Antenna", Proceedings of the 1992 IEICE Spring Conference, B-82 (1992-03).
- [5] M.Haneishi, et.al: "A Design Method of Circularly Polarized Rectangular Microstrip Antenna by One-Point Feed", Electron & Commun in Japan, 54, pp.46-54 (Apr.1981).