

Verification of On-Vehicle Media Applicability of a Metamaterial Antenna

Kazushi Kawaguchi*, Yuji Sugimoto*, Takafumi Nishi**, Ichiro Shigetomi**

*NIPPON SOKEN, INC.,
 14 Iwaya, Shimohasumi-cho, Nishio, Aichi 445-0012 Japan
 Phone: +81-563-55-1813, Fax: +81-563-55-1814
 E-mail: [kazushi_kawaguchi | yuji_sugimoto]@soken1.denso.co.jp

** DENSO CORPORATION
 1-1 Showa-cho, Kariya, Aichi 448-8661, Japan
 E-mail: ichiro_shigetomi@denso.co.jp

1. Introduction

Antennas for vehicles are experiencing great demand for miniaturization and integration from the point of space-savings and improved flexibility. The dipole antenna of a left-handed transmission line using metamaterial technology for miniaturization has been reported[1][2]. Since a metamaterial antenna has two or more resonance modes, its use is also expected for antenna integration. However, verification of applicability of on-vehicle media has been very rare.

In this report, we verified the adaptability of the UHF band monopole antenna using a metamaterial. The verified media was RKE (remote keyless entry) in the 300 MHz band and V2X wireless communication in the 700 MHz band. A metamaterial antenna covering both bands was designed, and its realization was verified by installing on a roof.

2. Design method of the multiband antenna using a metamaterial

This section explains the antenna design method corresponding to the RKE of 300 MHz band and V2X of 700 MHz band. We used a left-handed transmission line, a conventional technology, and using actively the right-hand transmission line at the time of parallel resonance. Accordingly, we realized a multiband antenna that operated in the two frequency bands. The equivalent circuit of the antenna is shown in Fig. 1. The antenna consists of two periods. Since the length of one period is much smaller than that of wavelength at 300MHz or 700MHz, it can approximate enough in this equivalent circuit. One period has length of $a=25$ mm and consists of shunt inductance L_L and series capacitance C_L showing the left-handed transmission line characteristic, shunt capacitance C_R and series inductance L_R showing the right- handed transmission line characteristic.

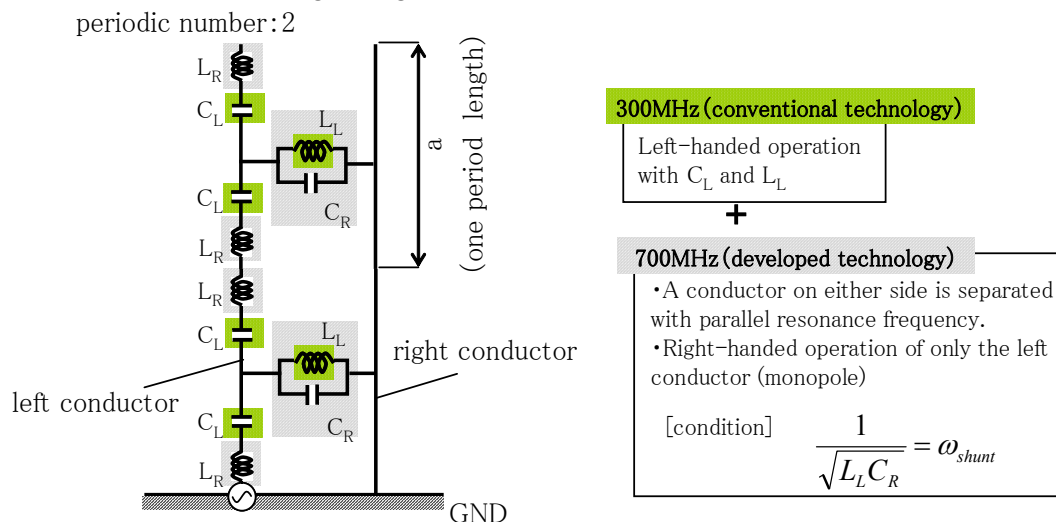

Fig.1. Equivalent circuit of monopole antenna using metamaterial

2.1 Design of 300 MHz band antenna using a left-handed transmission line

Miniaturization is needed in order to form an antenna with 50 millimeters long (0.05λ) in the 300 MHz band (ω_1). Therefore, a monopole metamaterial antenna using the left-handed transmission line with miniaturization is realized. To operate it using a left-handed antenna, it is necessary to design the distributed elements according to ω_1 to satisfy the equation [3] :

$$\beta a = \cos^{-1} \left[1 - \frac{1}{2} \left\{ \frac{1}{\omega_1^2 L_L C_L} + \omega_1^2 L_R C_R - \left(\frac{L_R}{L_L} + \frac{C_R}{C_L} \right) \right\} \right] \quad (1)$$

In equation (1) above, β is the phase coefficient.

2.2 Design of 700 MHz band antenna using a right-handed transmission line

In the conventional structure, L_R and C_R arise inevitably in the conductors composing transmission lines. To control operation of the two frequency bands using a single source, it is considered using positively not only C_L and L_L , which shows a left-handed transmission line, but also L_R and C_R , which shows a right-hand transmission line.

Specifically, parallel resonance of L_L and C_R is applied with a 700 MHz band, and the left conductor and right conductor in Fig. 1 is separated because the portion had high impedance. Also, it is operated as a usual monopole antenna only with the left conductor. So, it operated as a left-handed antenna at ω_1 , and as a right-handed antenna accompanied by parallel resonance using ω_2 . To carry out parallel resonance and function as a right-hand antenna at ω_2 , it is necessary to satisfy the following equation.

$$\omega_2 = \sqrt{1/L_L C_R} \quad (2)$$

Next, the method of improving radiation efficiency at the time of right-hand system operation is shown below. L_R and C_L are set up to cancel out the radiation impedance imaginary part A of only the left conductor to emit an electric wave efficiently. In this case, that is when A , L_R , and C_L satisfy the relation in the following equation.

$$A + \omega_2 L_R - 1/\omega_2 C_L = 0 \quad (3)$$

An outline of the flow that actually determines each constant L_L , C_R , L_R and C_L using the above-mentioned relations is as follows. First, determine the two resonating frequencies. Set the low frequency as ω_1 and high frequency as ω_2 . Determine the element height. Also, Model only the left conductor at 700 MHz, evaluate input impedance by a simulation.

As the result, we obtain the constants ω_1 , ω_2 , and A , They can be substituted for the equations (1), (2), and (3). So, each constant C and L can be determined.

2.3 Antenna structure

An actual implementation of the antenna is shown in Fig.2. The series capacitance C_L and shunt inductance L_L consists of interdigital capacitor C_L and meander inductor L_L , respectively. To also adjust the parallel resonance frequency to 700 MHz, we introduce C_{R2} which is consisted of back patterns in addition to C_{R1} formed between two parallel lines. ($C_R = C_{R1} + C_{R2}$). This structure enables control of the operation frequency.

Moreover, in order to increase $L_R (=L_{R1} + L_{R2})$, the lumped constant L_{R2} is added to L_{R1} component which naturally derived from the line length. Therefore, the electric length of the left conductor became one-quarter wavelength at 700MHz. The lumped constant inductor is placed over the slit formed in the left conductor.

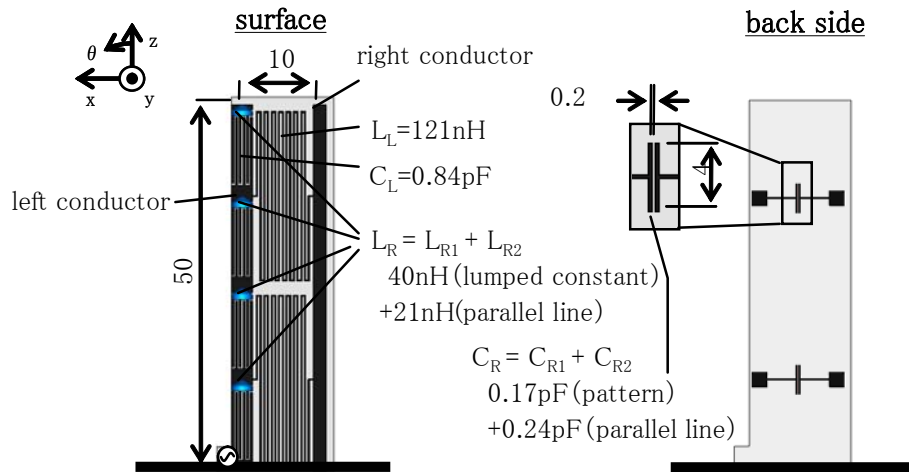

Fig.2. Antenna structure

3. Results of antenna performance simulation

In this section, we show the simulated estimation of the antenna explained in the preceding section. The target performance of RKE and V2X are shown in Table 1.

Table.1. Target performance of RKE and V2X

media	RKE	V2X
Frequency band (MHz)	300	700
Gain (dBi)	-15	-3
bandwidth(MHz)	10	10

First, the results of impedance characteristic in VSWR is shown in Fig. 3. As the figure shows, it is resonating in the 300 MHz band of RKE, and the 700 MHz band of V2X, therefore, the multiband characteristics of the antenna is confirmed. Although resonances appeared in other frequency bands, these are considered to be high order resonance modes. It is confirmed that the bandwidth is 25 MHz in the 300 MHz band and 31 MHz in the 700 MHz band, and fulfils the target bandwidth. VSWR is evaluated in the frequency band that is three or less.

Next, the analysis results of theta polarization, the main polarization on the xy side, are shown in Fig. 4. From the figure, it is shown that average radiation patterns -11.9 dBi at 340 MHz and 0.2 dBi at 710 MHz can be confirmed, and both satisfy the desired values in Table 1. Moreover, its characteristics having realized horizontal non-directivity, which does not have NULL in RKE and V2X, can also be confirmed.

Therefore, it is confirmed that the designed magnetic monopole metamaterial antenna can be applied to V2X and RKE.

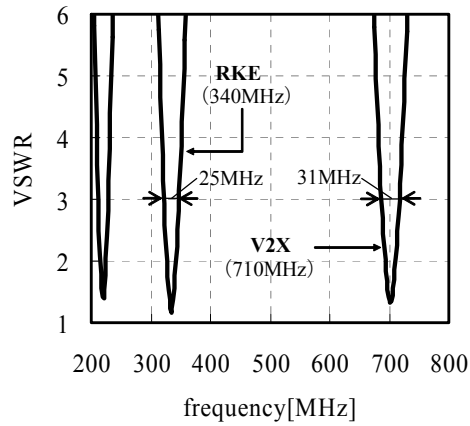

Fig.3. Analysis result of an impedance characteristic

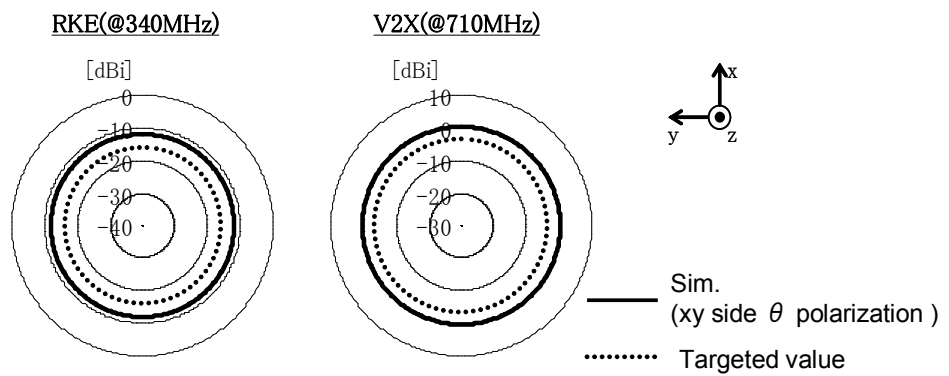

Fig.4. Analysis results of theta polarization

4. Conclusion

A monopole metamaterial antenna was designed for RKE and V2X, as an in-vehicle media in the UHF band, and multiband functionality was confirmed.

Operation of a conventional left-handed antenna was carried out in the 300 MHz band of RKE.

In the 700 MHz band of V2X, right-hand antenna operation was realized by separating the left and right conductors using parallel resonance.

This result shows that operating frequency could be adjusted by adding shunt C_R and series L_L , and that multiband operation with high gain can be achieved.

References

- [1] Iizuka, H., P.S. Hall, and A.L. Borja, "Dipole antenna with left-handed loading," *IEEE Antennas and Wireless Propagation Letters*, Vol. 5, No. 1, 483–485, 2006.
- [2] Liu, Q., P. S. Hall, and A. L. Borja, "Efficiency of electrically small dipole antennas loaded with left-handed transmission lines," *IEEE Transactions on Antennas and Propagation*, Vol. 57, 3009–3017, 2009.
- [3] C. Caloz and T. Itoh, *Electromagnetic Metamaterials - Transmission Line Theory and Microwave Applications*, John Wiley & Sons, Inc., 2006.