

# Composite Right/Left-Handed Leaky-Wave Antenna with Polarization Control

#Kohei Nishishita, Kazuhiro Kitatani, Yasuyuki Okamura  
 Graduate School of Engineering Science, Osaka University  
 1-3 Machikaneyama, Toyonaka, Osaka, 560-8531 Japan  
 e-mail: kohei.nishishita@ec.ee.es.osaka-u.ac.jp

## 1. Introduction

Metamaterials have an artificial structure, where unit cells are arranged at intervals shorter than the operation wavelength. Having their unique characteristics which are not found in nature, they have been receiving a lot of attention [1]. For example, the size of a metamaterial antenna is smaller than that of a conventional one. Moreover, a composite right/left-handed transmission line (CRLH-TL) leaky wave antenna has wide beam directivity [2], so it can be applied to mobile communications.

Recent studies have looked into the characteristics of CRLH-TL leaky wave antennas with linear polarization control by switching excitation mode (common mode and differential mode) [3]. Previously, we have proposed a new simple structure for the CRLH-TL circular polarization antenna, and confirmed the operation of circular polarization [4-5]. In this paper, we propose a 2-dimensional CRLH-TL microstrip leaky wave antenna, which can operate with four different polarized waves, and show the result of the simulation.

## 2. Structure and operation of the proposed antenna

The structure of the proposed antenna and the coordinates are shown in Fig. 1. The equivalent circuit for the unit cell can be expressed in Fig. 2. The detailed layout and parameters of the antenna are shown in Fig. 3 and Table 1. The unit cell of this antenna consists of series capacitors, a shunt inductor, and a via-free virtual ground capacitor, therefore it has left-handed capacitance ( $C_L$ ) and inductance ( $L_L$ ), along with right-handed capacitance ( $C_R$ ) and inductance ( $L_R$ ). In Fig. 2,  $C_g$  is the virtual ground capacitance.

We apply signals from the left side (Port1 and Port3), and attach resistances of 50 ohms to the right side (Port2 and Port4). There are four excitation patterns: (1) Port1 only, (2) Port3 only, (3) Port1 and Port3 in-phase, and (4) Port1 and Port3 180 degrees out-of-phase. In addition, we attach resistances of 50 ohms to the input port when no signal is applied.

We simulate this antenna by using the computer software HFSS, which is a finite element method (FEM) solver. We employ a 0.8 mm-thick printed substrate with a relative permittivity of 2.2 and a loss tangent of  $6 \times 10^{-4}$ . The unit cell is aligned with a space  $S$  of 3.85 mm and a gap  $g$  of 0.2 mm. The number of unit cells for each column is 10. The two columns of the CRLH-TL antenna are symmetrically arranged at the center line, with a distance  $d$  of about half a wavelength.

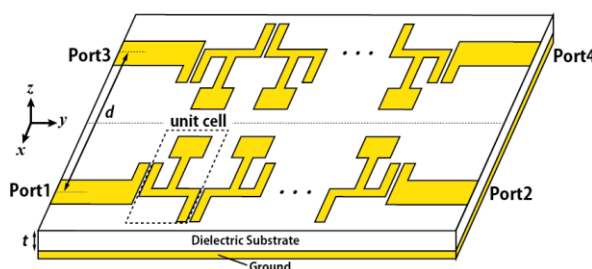

Figure 1: Structure of the proposed antenna

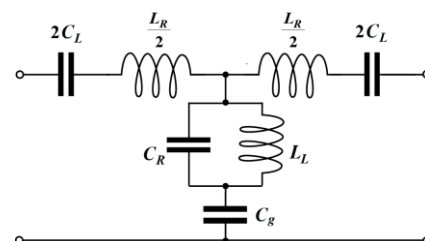

Figure 2: Equivalent circuit for unit cell

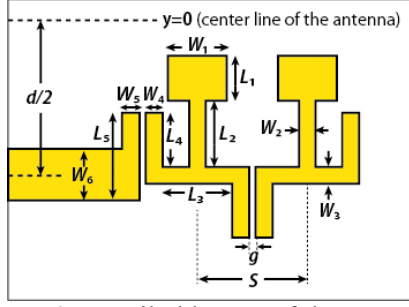

Figure 3: Detailed layout of the antenna

Table 1: Parameters of the antenna (unit: mm)

$W_1$	1.75	$L_1$	1.5
$W_2$	0.375	$L_2$	2.25
$W_3$	0.375	$L_3$	2.25
$W_4$	0.7	$L_4$	2.26
$W_5$	0.7	$L_5$	3.25
$W_6$	2.34	$S$	3.85
$d$	14.34	$g$	0.2
$t$	0.8		

The operation of the antenna is shown in Fig. 4. Each arrow represents the instantaneous current. When we apply a signal to Port1 only (Fig. 4(a)), the current components in the two capacitors of the left and right side are cancelled. Therefore, there are only two currents left, in the  $y$ -direction (red arrow) and  $x$ -direction (blue arrow). The unit cell is designed to equalize the amplitudes of the two and to give a different phase in the orthogonal directions. This phase difference comes from the difference of the starting point of the two currents (point “a” and “b” in Fig. 4(a)), so when the phase difference is about 90 degrees, operation of the right-handed circular polarized wave can be expected to occur [4-5]. Similarly, when we apply a signal to Port3 only, operation of the left-handed circular polarized wave can be expected to occur.

A linear polarized wave is considered a superposition of the right-handed and left-handed circular polarized waves. When we apply signals to Port1 and Port3 in-phase (Fig. 4(b)), the two columns of the antenna are live with electricity symmetrically about the  $y$ -axis. As a result, the currents in the  $x$ -direction are cancelled, and only the currents in the  $y$ -direction remain. That is, operation of the  $y$ -direction linear polarized wave is expected to occur. Likewise, when we apply signals to Port1 and Port3 180 degrees out-of-phase (Fig. 4(c)), the currents in the  $x$ -direction remain, so operation of the  $x$ -direction linear polarized wave is expected to occur. Therefore, by switching the excitation ports, it is expected that the proposed antenna can operate with four different polarized waves: right-handed circular polarized wave, left-handed circular polarized wave,  $y$ -direction linear polarized wave, and  $x$ -direction linear polarized wave.

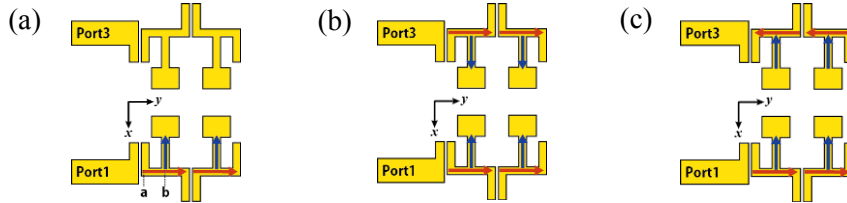

Figure 4: Operation of the antenna when we apply a signal (or signals) (a) to Port1 only, (b) to Port1 and Port3 (in-phase) and (c) to Port1 and Port3 (180° out-of-phase)

### 3. Simulation results

The dispersion characteristics are shown in Fig. 5(a).  $\beta$  is a phase constant of the transmission line. The proposed antenna has balanced dispersion characteristics. When we apply a signal to Port1 only,  $\beta$  is set to be zero at the frequency ( $f_0$ ) of 11.97 GHz. For the in-phase excitation and 180 degrees out-of-phase excitation of Port1 and Port3,  $f_0$  is 11.95 GHz and 11.82 GHz, respectively. When the frequency is lower than  $f_0$ , this antenna operates in the left-handed region of  $\beta < 0$ . On the other hand, when the frequency is higher than  $f_0$ , this antenna operates in the right-handed region of  $\beta > 0$ . The radiation region is the region of  $\beta < k_0$ , where  $k_0$  is a free-space wave number. An air line refers to the dispersion characteristics in the air ( $\omega = \beta c_0$ ). When  $\theta$  is defined as the angle measured from the  $z$ -axis in the  $y$ - $z$  plane, the main beam scanning angle  $\theta_{MB}$  is described as follows [2]:

$$\theta_{MB} = \sin^{-1}(\beta/k_0) \quad (1)$$

From equation (1), when  $\beta < 0$  (left-handed region), the beam direction is backward, and when  $\beta > 0$  (right-handed region), the beam direction is forward. Therefore, we can say that this antenna can change its beam direction by changing the frequency. Moreover, from in Fig. 5(a) and equation (1), it can be concluded that the beam direction varies more drastically in the left-handed region than the right-handed region (see Fig. 5(b)). For every pattern of excitation, the beam direction advances forward as the frequency increases.

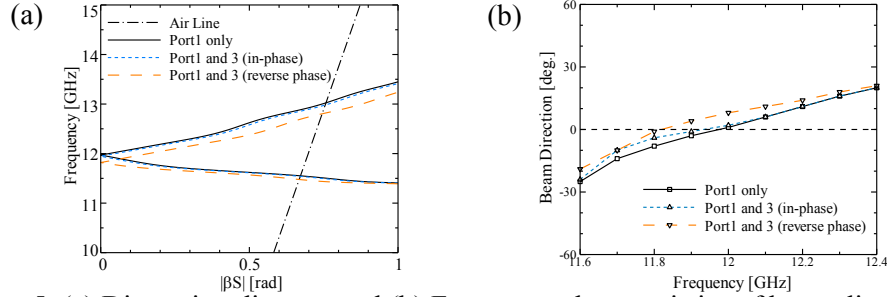

Figure 5: (a) Dispersion diagram and (b) Frequency characteristics of beam direction

The simulated radiation patterns of the  $y$ -direction component ( $E$ ) and the  $x$ -direction component ( $E_c$ ) are shown in Fig. 6 when only Port1 is excited. Fig. 6(a), (b), and (c) show the patterns at 11.7 GHz, 12.0 GHz, and 12.3 GHz, respectively. The beam direction is broadside at 12.0 GHz, backward ( $\theta_{MB} = -14$  degree) at 11.7 GHz, and forward ( $\theta_{MB} = 16$  degree) at 12.3 GHz. At each frequency, the amplitude difference of the main beam is (a) 3.2 dB, (b) 0.4 dB, and (c) 2.6 dB. The frequency characteristics of the amplitude difference, phase difference, and axial ratio in the radiation region are shown in Fig. 7. At 12.0 GHz, the amplitudes of  $E$  and  $E_c$  are almost the same (Fig. 7(a)), and the phase difference is 75 degrees (Fig. 7(b)), which leads to the axial ratio of 2.3 dB (Fig. 7(c)). This means the antenna operates with a circular polarized wave. It is also confirmed that the axial ratio is near 3 dB in the range 11.7 GHz to 12.4 GHz.

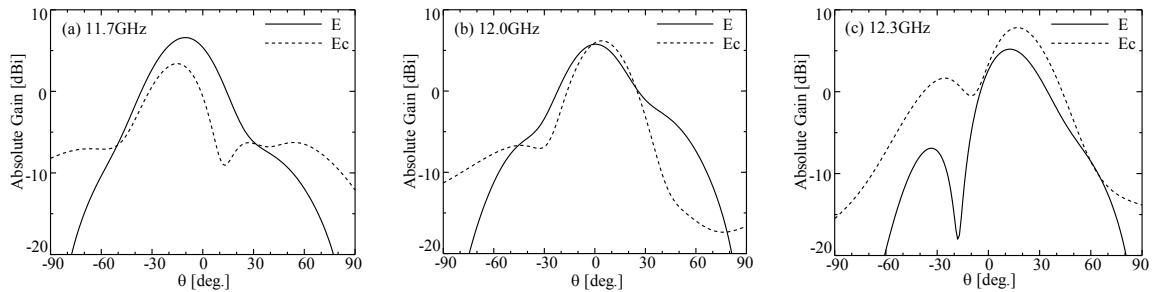

Figure 6: Radiation patterns when a signal is applied to Port1 only

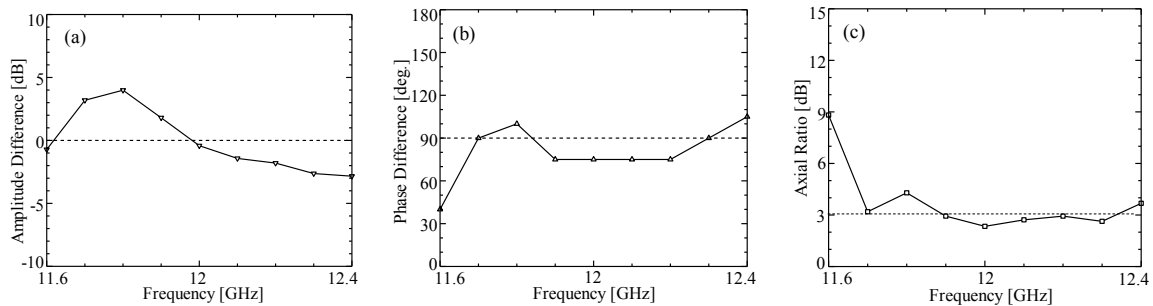

Figure 7: (a) Amplitude difference, (b) Phase difference, and (c) Axial ratio

The simulated radiation patterns of the  $y$ -direction component  $E$  and  $x$ -direction component  $E_c$  are shown in Fig. 8 when we apply in-phase signals to Port1 and Port3. Figure 8(a), (b), and (c) show the patterns at 11.7 GHz, 12.0 GHz, and 12.3 GHz, respectively. At each frequency, the absolute gain of the  $E$  component is much bigger than that of the  $E_c$  component. The amplitude differences are: 13.5 dB at 11.7 GHz, 17.8 dB at 12.0 GHz, and 11.9 dB at 12.3 GHz. Therefore, we can say that the antenna operates with a  $y$ -direction linear polarized wave. On the other hand, in the

case of the 180 degrees out-of-phase excitation of Port1 and Port3 (the radiation patterns are shown in Fig. 9), the absolute gain of the  $E_c$  component is bigger than that of the  $E$  component. The amplitude differences are: 3.8 dB at 11.7 GHz, 18.1 dB at 12.0 GHz and 15.8 dB at 12.3 GHz. That is, the antenna operates with an  $x$ -direction linear polarized wave at 12.0 GHz and 12.3 GHz, but suppressing the  $E$  component is insufficient at 11.7 GHz.

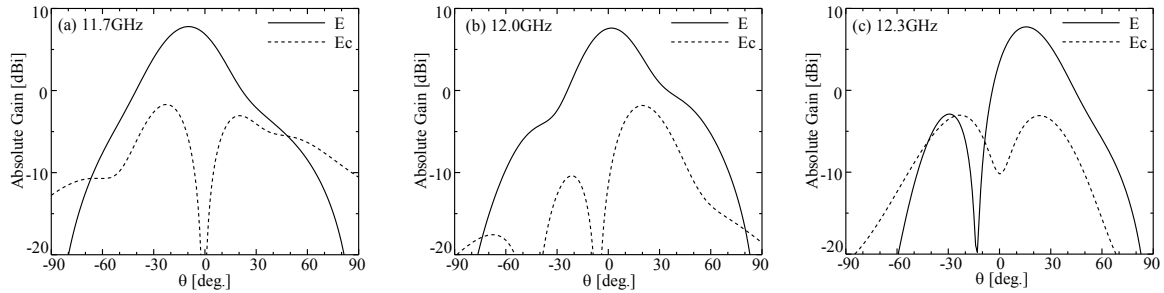

Figure 8: Radiation patterns when signals are applied to Port1 and Port3 (in-phase)

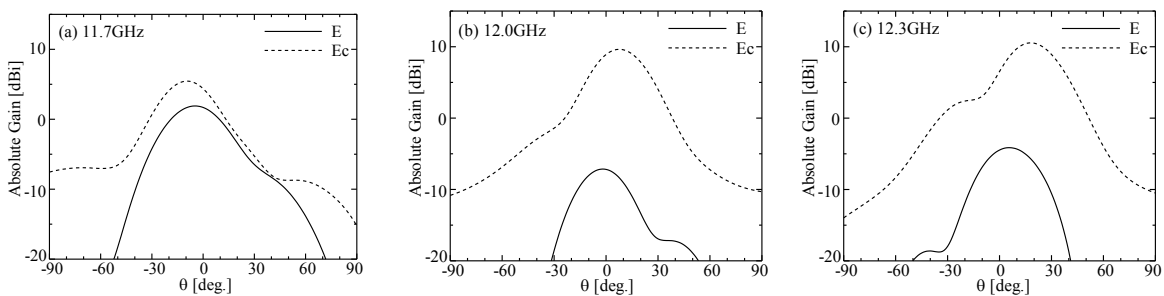

Figure 9: Radiation patterns when signals are applied to Port1 and Port3 (180° out-of-phase)

## 4. Conclusion

In this paper, we proposed a two-column CRLH-TL microstrip leaky-wave antenna with polarization control. From the result of the simulation, we conclude that this antenna can operate with four different polarized waves by switching the patterns of excitation. Moreover, the angle of the main beam can be changed by changing the frequency of all polarized waves. In the future, we plan to improve the antenna design in order to make it operate better.

## Acknowledgements

We would like to thank Prof. Hiroshi Murata and Dr. Hidehisa Shiomi for their constant encouragement.

## References

- [1] T. J. Cui, D. R. Smith, and R. Liu, *Metamaterials Theory, Design and Applications*, first edition, Springer-Verlag, New York, pp.1-5, 2009
- [2] C. Caloz and T. Itoh, *Electromagnetic Metamaterials Transmission Line Theory and Microwave Applications*, first edition, Wiley-Interscience, Hoboken, pp.261-282, 2006
- [3] M. R. M. Hashemi and T. Itoh, "Coupled Composite Right/Left-Handed Leaky-Wave Transmission Lines Based on Common/Differential-Mode Analysis," *IEEE Transactions on Microwave Theory and Techniques*, Vol.58, No.12, pp.3645-3656, 2010
- [4] Y. Mitsuhashi, R. Osagawa, K. Kitatani, and Y. Okamura, "Circularly Polarized Microstrip Leaky Wave Antenna Using Composite Right/Left-Handed Transmission Line," *The 15th International Symposium on Antennas and Propagation*, Macao, China, pp.45-48, 2010
- [5] K. Kitatani, Y. Mitsuhashi, and Y. Okamura, "Circularly Polarized Leaky Wave Antenna Without Phase Shifter Using CRLH Transmission Line," *The 6th European Conference on Antennas and Propagation 2012*, Prague, Czech, CA05, 2012