

A Printed UWB Diversity Antenna

Haiping Zhao ¹, Libiao Liu ¹, Terence S. P. See ², Zhi Ning Chen ^{1,2}, Max J. Ammann ³

¹Nanyang Technological University, School of Electrical and Electronic Engineering

Blk S1, 50 Nanyang Avenue, Singapore 639798

zhaohp@pmail.ntu.edu.sg

²Institute for Infocomm Research, Radio Systems Department

20 Science Park Road #02-21/25 TeleTech Park, Singapore 117674

spsee@i2r.a-star.edu.sg, chenzn@i2r.a-star.edu.sg

³Dublin Institute of Technology, Ireland, School of Electronic and Communications Engineering

Kevin St. Dublin 8, Ireland

max.ammann@dit.ie

Abstract

This paper presents an ultra-wideband diversity antenna printed on a PCB. The antenna consists of two squares with an equilateral right-angled triangle which are orthogonally and symmetrically printed on a PCB with a slotted ground plane. A parametric study is conducted to examine the effects of the slots on the impedance matching and isolation. The simulated and measured results show that the proposed antenna is capable of providing good port isolation of $|S_{21}| < -20$ dB across the operating bandwidth of 3.1 GHz–6 GHz for a 10-dB return loss with pattern diversity.

I. INTRODUCTION

Today, ultra-wideband (UWB) technology is proposed for high speed data transmission. It is used to transmit data between devices in the immediate area up to 10 meters. The amount of bandwidth by a UWB signal is at least 25% of the center frequency or more than 1.5 GHz. In order to enhance the quality of wireless communication in a dense environment, antenna diversity has been widely used. There are several diversity techniques such as spatial diversity, where it requires two or more antennas to be sufficiently spaced apart such that the branch signals have a higher probability of fading independently; polarization diversity, where independent reception is possible with two orthogonal polarizations and the two resulting signals do not fade in a correlated manner; and radiation pattern diversity, which uses antennas with different beams on each branch. Therefore, each channel receives the transmitted signal with different strengths depending on the branch pattern and the propagation characteristics at that moment in time. In this paper, a UWB pattern diversity antenna printed on a PCB will be presented [1]. The proposed antenna is able to achieve a broad impedance bandwidth for $|S_{11}| < -10$ dB of 3.1 GHz–6 GHz [2], as well as a good port isolation for $|S_{21}| < -20$ dB across the bandwidth for diversity applications. This antenna provides diversity to ease the multi-path fading problem in dense environments and enhance the performance of wireless UWB communication systems [3, 4]. The design and

simulation of the UWB diversity antenna are carried out with the aid of the EM simulator Zeland IE3D.

II. ANTENNA DESIGN

The geometry and the co-ordinate system of the proposed UWB diversity antenna are shown in Fig. 1. The antenna is printed on the top surface of the 1.52 mm-thick dielectric substrate (Rogers 4003, $\epsilon_r = 3.38$) with size of 50 mm×80 mm. Each square radiator is joined to an equilateral right-angled triangle. The two radiators are orthogonally oriented at the upper left and right corners of the PCB. The dimension of the square radiator is 14 mm×14 mm. Each radiating element is excited by a 50Ω co-axial probe of a radius of 0.6 mm at the midpoint of the bottom of the square. To suppress the coupling between the two ports, two narrow parallel slots measuring 50 mm×2 mm are cut from the ground plane. The distance between the two slots is 20 mm. A wide slot of width 9 mm and length 20 mm is centrally cut from the top portion of the ground plane. The parameters of the antenna are determined by simulation and experiment.

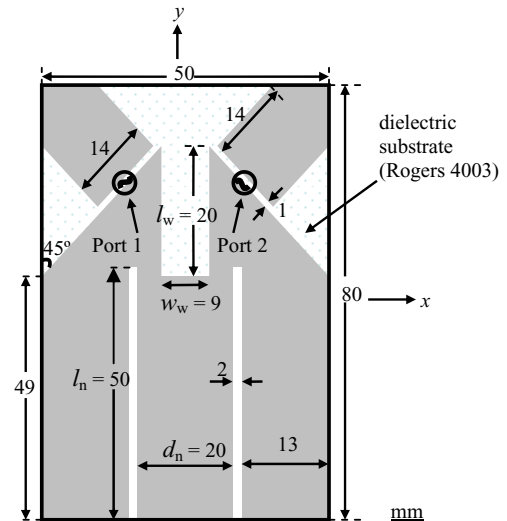

Fig. 1: Geometry of proposed antenna

III. PARAMETRIC STUDY

A parametric study was conducted to investigate the effects of the slots on the impedance matching and isolation. This will be helpful for antenna designers to optimize the antenna parameters for desired performance. The introduction of the slots is primarily to enhance the isolation and impedance matching performance. The length of the narrow slots l_n , the distance between the narrow slots d_n , and the length l_w and width w_w of the wide slot are varied. In the simulations, the values of the parameters are the same as that shown in Fig. 1, except for the parameter under investigation.

From Fig. 2(a), it is seen that when the length of the narrow slots l_n are varied from $l_n=48$ mm to 52 mm, the impedance matching $|S_{11}|$ is kept almost unchanged but the isolation $|S_{21}|$ is observed to be sensitive to changes in the slot length. The distance between the slots (d_n) affects the isolation mainly at their resonances as shown in Fig. 2(b).

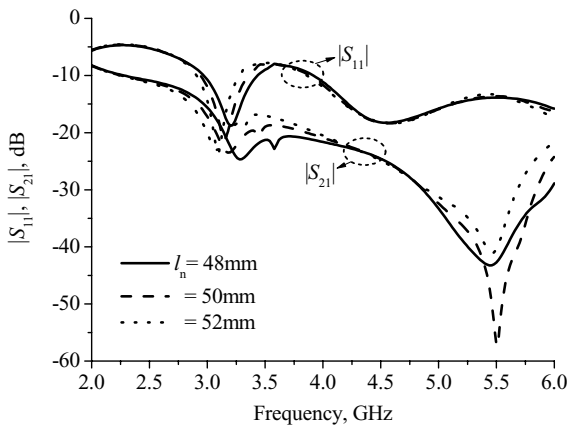

Fig. 2(a): Effects of varying the length of the narrow slot l_n

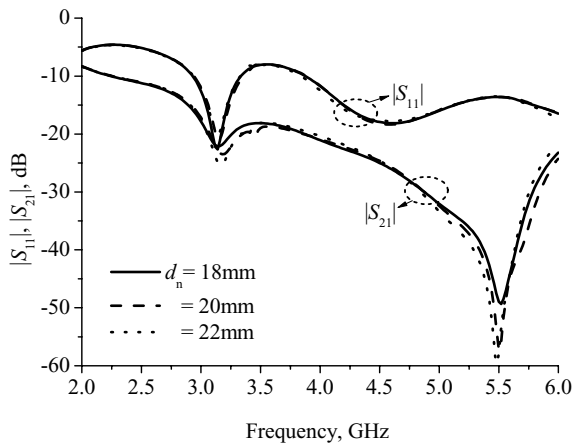

Fig. 2(b): Effects of varying the distance between the slots d_n

From Fig. 2(c), it can be observed that when the length of the wide slot (l_w) is varied from 18 mm to 22 mm, the isolation is predominantly changed. However, both the impedance matching and the isolation are quite sensitive to changes in the width of the wide slot (w_w) when it is varied from 8 mm to 10 mm as shown in Fig. 2(d).

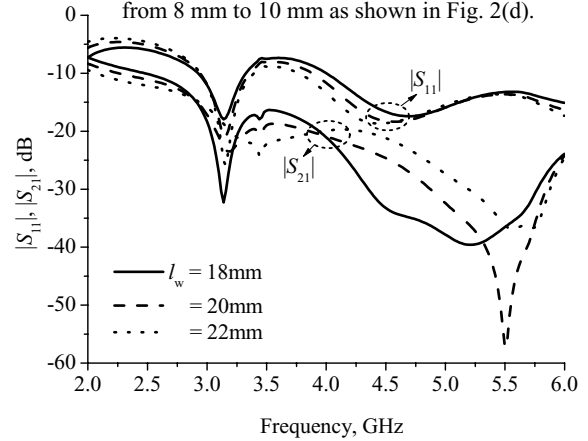

Fig. 2(c): Effects of varying the length of the wide slot l_w

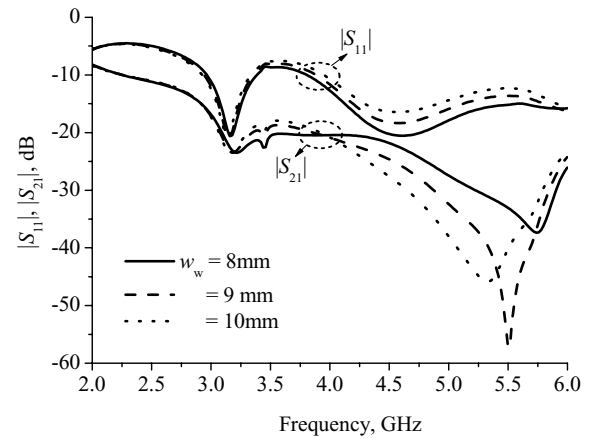

Fig. 2(d): Effects of varying the width of the wide slot w_w

IV. EXPERIMENTAL RESULTS AND DISCUSSIONS

The proposed antenna was studied experimentally. Fig. 3(a) shows a photo of the antenna with the feeding semi-rigid coaxial cable. The inner conductor of the cable is soldered onto the radiator and the outer sleeve is soldered onto the ground plane. Fig. 3(b) shows the measured and simulated return loss $|S_{11}|$ and port isolation $|S_{21}|$ against frequency. From the figure, it can be found that the simulations and measurements are in good agreement. The measured results show an impedance matching bandwidth of 3.1 GHz–6 GHz for $|S_{11}| < -10$ dB and a good isolation of >20 dB across the range of 3.1

GHz–6 GHz. Therefore, the antenna is suitable to be used for UWB diversity applications.



Fig. 3(a): Photo of proposed antenna

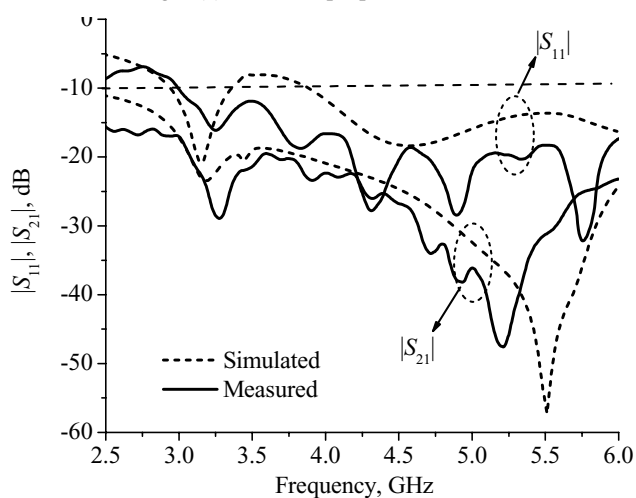
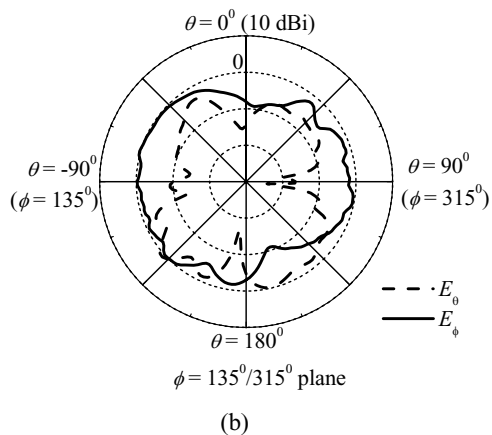
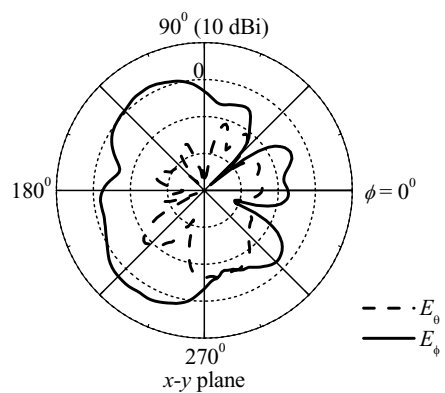

Fig. 3(b): S-parameters of proposed antenna

Figs. 4 to 7 show the radiation characteristics of the antenna at 3.5 GHz and 5.5 GHz in three principal planes, namely the x - y plane, the $\phi = 45^\circ/225^\circ$ and $\phi = 135^\circ/315^\circ$ cuts.



(b)



(c)

Fig. 4: Radiation patterns at 3.5 GHz with Port 1 excited in the (a) $\phi = 45^\circ/225^\circ$ plane (b) $\phi = 135^\circ/315^\circ$ plane (c) x - y plane

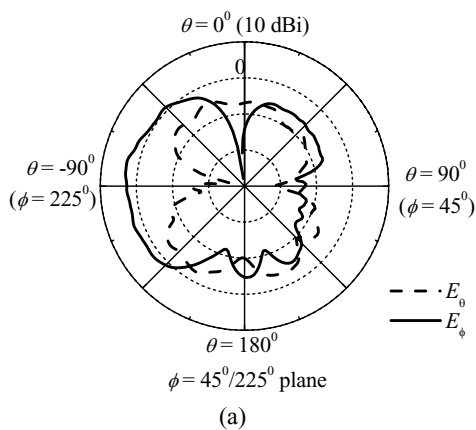

(a)

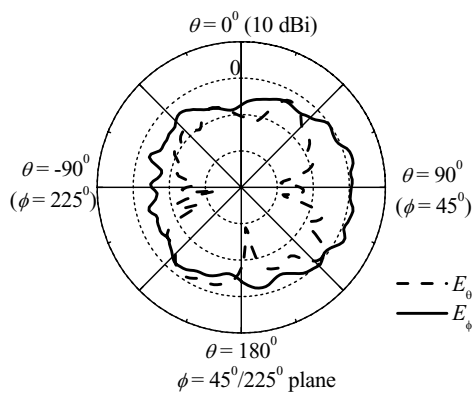

(a)

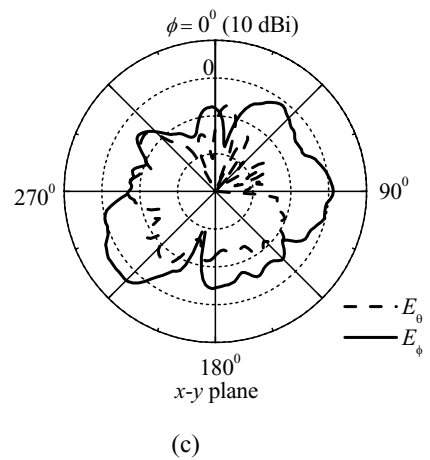
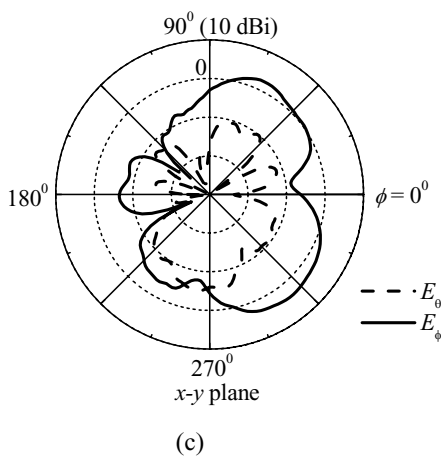
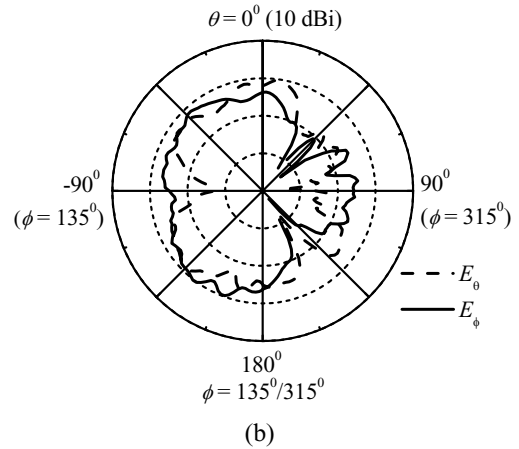
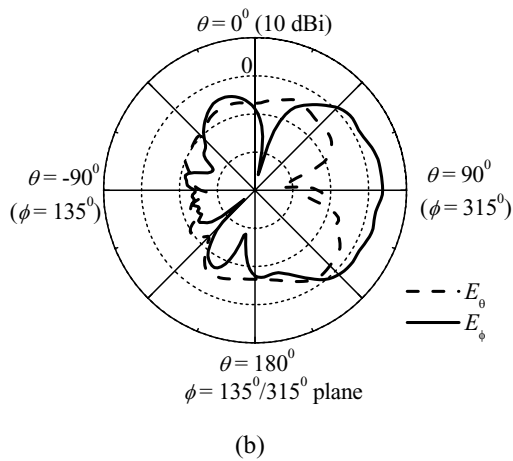
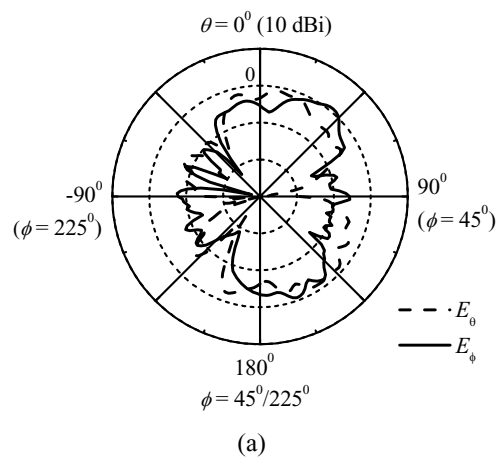
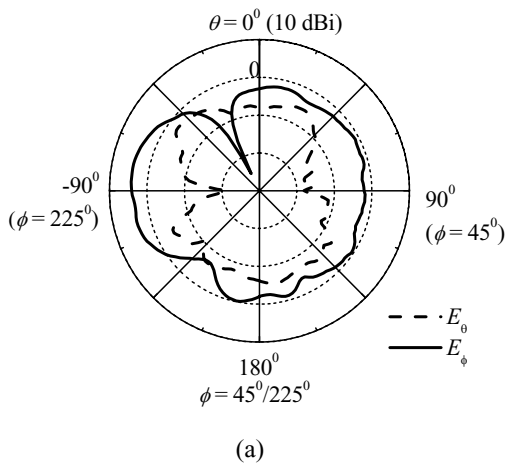

Fig. 5: Radiation patterns at 3.5 GHz with Port 2 excited in the (a) $\phi = 45^\circ/225^\circ$ plane (b) $\phi = 135^\circ/315^\circ$ plane (c) x - y plane

Fig. 6: Radiation patterns at 5.5 GHz with Port 1 excited in the (a) $\phi = 45^\circ/225^\circ$ plane (b) $\phi = 135^\circ/315^\circ$ plane (c) x - y plane



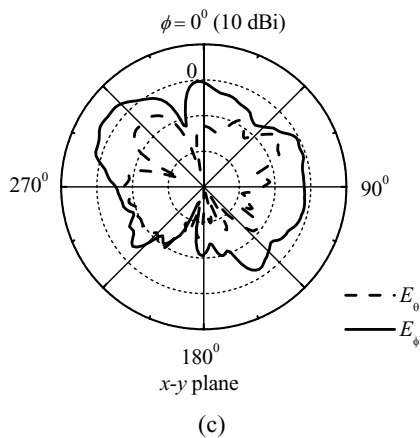
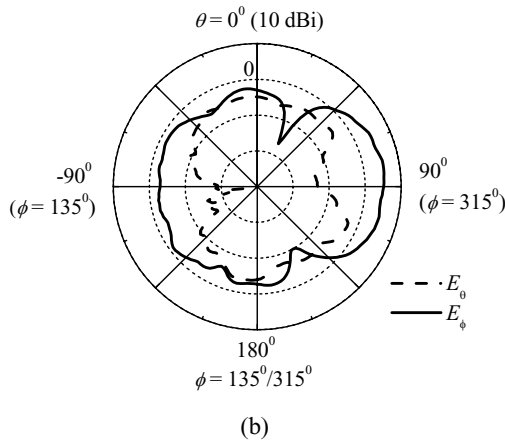

Fig. 7: Radiation patterns at 5.5 GHz with Port 2 excited in the (a) $\phi = 45^\circ/225^\circ$ plane (b) $\phi = 135^\circ/315^\circ$ plane (c) x - y plane

In the measurements, when Port 1 is excited, Port 2 is terminated by a $50\text{-}\Omega$ load and vice versa. Comparing the patterns at $\phi = 45^\circ/225^\circ$ (Port 1 excited) with $\phi = 135^\circ/315^\circ$ (Port 2 excited), it can be observed that they cover complementary spatial regions. Similarly, the same phenomenon can be observed for the case of $\phi = 135^\circ/315^\circ$ (Port 1 excited) with $\phi = 45^\circ/225^\circ$ (Port 2 excited). Also, it can be seen from the measured radiation patterns that the antenna has stable radiation performance across the impedance bandwidth.

The measured peak gain of the total fields at three planes (x - y , $\phi = 45^\circ$, and $\phi = 135^\circ$) with the Port 1 excited is shown in Fig. 8. Due to the symmetrical structure, the gain when Port 2 is excited will be the same. From the measured results, it is seen that the variation of the peak gain of total radiated fields in the three planes is less than 3 dBi across the impedance bandwidth.

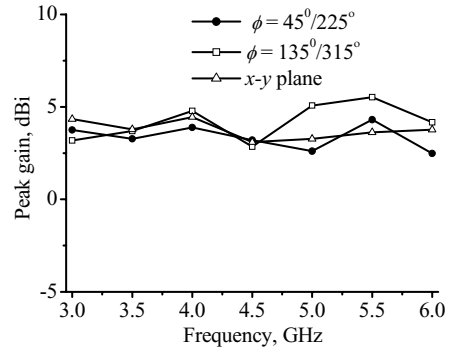

Fig. 8: Measured peak gain of the total fields

V. CONCLUSIONS

This paper has presented an ultra-wideband diversity antenna printed on a PCB. A parametric study has been conducted to investigate the effects of the slots on the impedance matching and isolation. The simulation and measurement results have shown that this antenna is capable of providing satisfactory pattern diversity performance and desired impedance matching across the 3.1–6 GHz bandwidth with good isolation.

REFERENCES

- [1] Z. N. Chen, X. H. Wu, H. F. Li, N. Yang, and M. Y. W. Chia, "Considerations for source pulses and antennas in UWB radio systems," *IEEE Trans. Antennas Propagat.*, vol. 52, no.7, pp. 1739-1748, July 2004.
- [2] K. L. Wong, S. W. Su, and Y. L. Kuo, "A printed ultra-wideband diversity monopole antenna," *Microwave Opt Techno Lett.*, vol. 38, no. 4, pp. 257-259, 2002.
- [3] M. J. Ammann and Z. N. Chen, "Wideband monopole antennas for multi-band wireless systems," *IEEE Antennas and Propagat. Magazine*, vol. 45, no. 2, pp. 146-150, Apr. 2003.
- [4] G. M. Chi, B. H. Li, and D. S. Qi, "Dual-band printed diversity antenna for 2.4/5.2 GHz WLAN application," *Microwave Opt Techno Lett.*, vol. 45, no. 6, pp. 561-563, 2005.