

# Small Circular Loop Antenna for RFID Tag

Hong-Kyun Ryu and Jong-Myung Woo  
 Department of Radio Science and Engineering,  
 College of Engineering, Chungnam National University,  
 Daejeon, Korea  
 hkryu@cnu.ac.kr and jmwoo@cnu.ac.kr

## Abstract

RFID Tag antennas are designed to miniaturize a circular loop antenna (CLA) by using short stubs inserted into the inner part of the loop at UHF band. This RFID tag antenna, in the case of one wavelength and a half-wavelength, respectively, is reduced up to 83% and 92.1% (except ground) of its size, compared with the general type CLA. Also the return loss, -10dB bandwidth, and gain of one wavelength and a half-wavelength are -11.9dB, 12MHz(1.3%), and -1.18dBd and -16.5dB, 48MHz(5%), and -0.58dBd respectively. The radiation pattern shows omni-directional pattern in z-y plane(x-axis pol.).

## 1. INTRODUCTION

Radio Frequency Identification (RFID) is replacing traditional barcode technology. It is possible to encode data into a microchip in tags for identifying, gathering and processing the information of products or as a tracking application. The RFID system uses LF(125kHz, 135kHz), HF(13.56MHz), UHF(433.92MHz, 860~960MHz) and Microwave(2.45GHz). In particular, the UHF(860~960MHz) band, which has long read range and low manufacturing costs, will be used as the system of distribution and logistics around the world [1],[2]. Usually, a RFID tag is composed by microchip storing information and antenna. To attach to any product, the RFID tag has to be a small size without degradation of a performance of the antenna. As a result of the development of semiconductor technology, the chip attached in the RFID tag is miniaturized. However, it is difficult to miniaturize the antenna because the size of the antenna is determined by the wavelength. Hence, in this paper, one wavelength and a half-wavelength CLA are designed and fabricated with the structure of short stubs in the Korea UHF RFID band (center frequency : 911.25MHz, bandwidth : 5.5MHz). This antenna takes advantage of production on a large scale due to its simple structure, small size, and the convenience of proceeding by print technology. Also, in order to miniaturize the antenna, we have inserted a series of short stubs into the inner part of the general CLA, so that we can increase the current path of the antenna and reduce the diameter of the antenna.

First, we have grasped the characteristics of feed structure on CLA to match the impedance. Then, to miniaturize CLA, we have dealt with the characteristics of CLA added a series of short stub. Furthermore, based on the result of this, we have designed and manufactured small sized CLAs, and we would like to explain the characteristics of this antenna.

## 2. DESIGN OF SMALL CLA

### A. Characteristics of feed structure on CLA

In this paper, the series-driven feed structure is used for impedance matching of  $1\lambda$  ( $\lambda$  : wavelength, 329mm) CLA[3],[4]. The structure has advantage in planer printing technique and smaller size environment.

The CLA feed structure is shown in Fig. 1 with inner feed structure and outer feed structure. To make a small size antenna, inner feed structure is selected. Because the outer feed structure has limit to make it small. Also, we compared with two feed structures on the feed length ( $L_1$  and  $L_2$ ), the feed gap ( $D_1$  and  $D_2$ ), and the radiation patterns to know the characteristics of two feed structures..

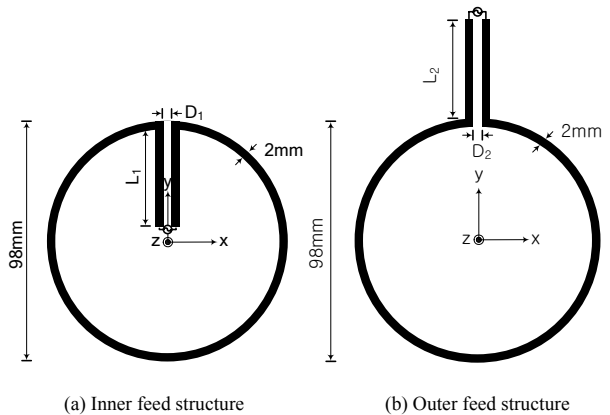

Fig. 1: CLA feed structure

Fig. 2 shows resonant frequency and impedance (911.25MHz) characteristics according to change of the feed length  $L_1$  and  $L_2$  with fixed  $D_1$  and  $D_2$ (2mm). When we varied the feed length  $L_1$  and  $L_2$  from 0mm to 80mm by 10mm, resonant frequency shows linear decrease for  $L_1$  from

1041MHz to 711MHz and for  $L_2$  from 1041MHz to 721MHz and impedance trace shows clockwise characteristic. This is due to the fact that the current distribution in longer feed line affects the total length of antenna. When  $L_1$  and  $L_2$  are shorter than 39mm, the capacitance is increased and then  $L_1$  and  $L_2$  are longer than 39mm, the inductance is increased. If the antenna's self impedance is regard as load impedance, change in input location from the load causes clockwise impedance trace.

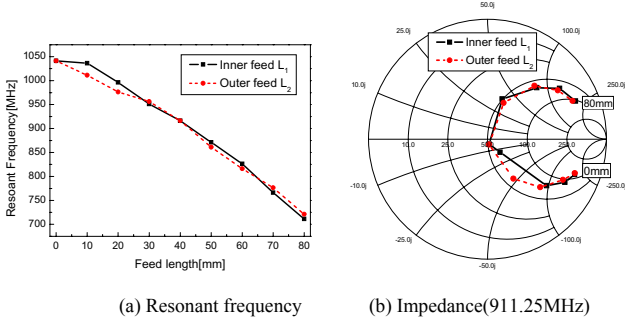

Fig. 2: Characteristics of feed length  $L_1$  and  $L_2$

Fig. 3 shows resonant frequency and impedance (911.25MHz) characteristics with fixed  $L_1$  and  $L_2$  at 39mm and different  $D_1$  and  $D_2$  from 0.5mm to 3.5mm by 0.5mm. The resonant frequency is decreased from 896.25MHz( $D_1$  and  $D_2$ ). As to impedance characteristics, capacitance is increased toward count clockwise when the gap of  $D_1$  and  $D_2$  are smaller. This is because each feed line works as part of independent antenna rather than as feed line when the gap of  $D_1$  and  $D_2$  are bigger. Therefore, the antenna characteristics are changed according to the length( $L_1$  and  $L_2$ ) and gap( $D_1$  and  $D_2$ ) of two feed structures. For the impedance matching, it is fixed that  $L_1$  and  $L_2=39$ mm, and  $D_1$  and  $D_2=2$ mm at 911.25MHz.

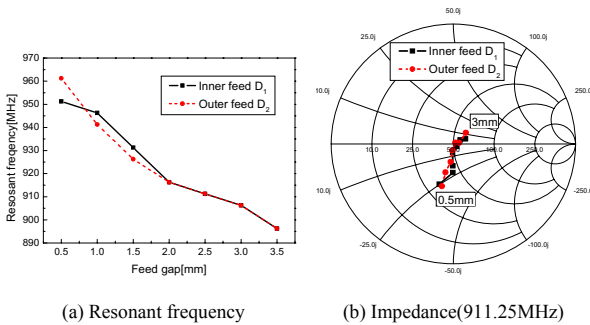

Fig. 3: Characteristics of feed gap  $D_1$  and  $D_2$

In case of the inner feed structure, the return loss and -10dB bandwidth are -22.5dB and 77.46MHz(8.5%) and for the outer feed structure, the return loss is -24dB and the -10dB bandwidth is 70MHz(7.6%). The result is almost same.

Fig. 4 shows the radiation pattern of two feed structures. In z-y plane which is x-axis polarization, the radiation pattern is omni-directional. The gain of inner and outer feed structure is 0.48dBd and 0.74dBd respectively. From the above results, we confirmed that there is no different in antenna

characteristics whether the feed structure is located inside(Fig.1(a)) or outside(Fig.1(b)) the loop. So inner feed structure has advantage in size reduction and we selected inner feed structure in this study. Also, using the length and gap of feed, we could adjust the impedance of the CLA.

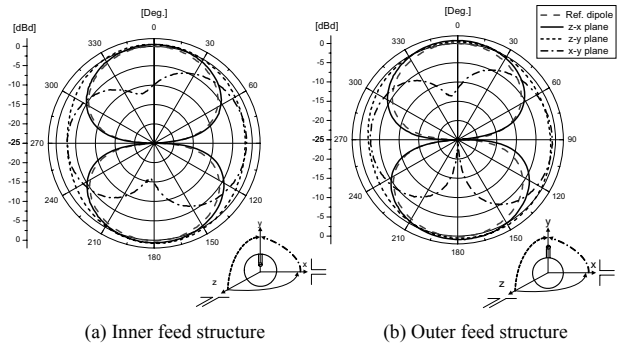

Fig. 4: Radiation pattern according to different feed method

### B. Characteristics of CLA using short stub[5],[6]

From the result in 2. A, it is made of a general printed type CLA using inner feed structure. A general printed type CLA is manufactured on a foam( $\epsilon_r = 1.06$ ) having the similar relative permittivity with air. Also, It is made of copper (thickness of 0.05mm). This antenna shows return loss of -22.5dB, -10dB bandwidth of 77.46MHz(8.5%), and the gain of 0.48dBd at design frequency of 911.25MHz.

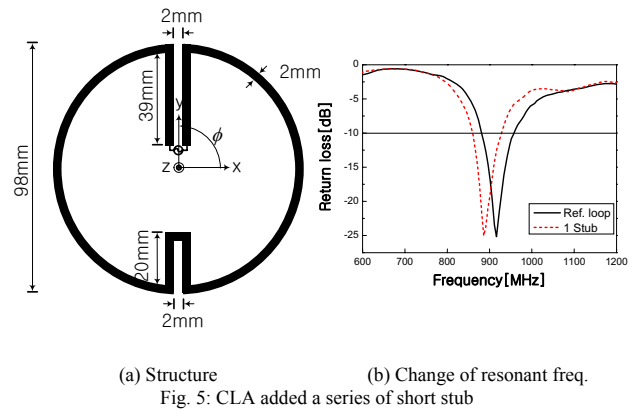

Fig. 5: CLA added a series of short stub

Fig. 5 shows characteristics of resonant frequency change when a series of short stub structure is implemented inside the loop on the general printed type loop antenna. The length of the stub is 20mm and the resonant frequency drops 30MHz(3.3%) from 911.25MHz to 881.25MHz when the line gap of the stub is 2mm. This is because the current is distributed along the stub and the total loop length is increased to 13%. Also, not only the capacitances are increased by expansion of the loop length, but also the inductances are increased by the structure of short stubs[7]. Therefore, the impedance of the antenna enables impedance matching that the loop length is longer than one wavelength,

so the frequency is eventually decreased. If it is resonant with the same frequency, the total loop diameter becomes smaller, so the loop antenna is miniaturized by the attached stubs.

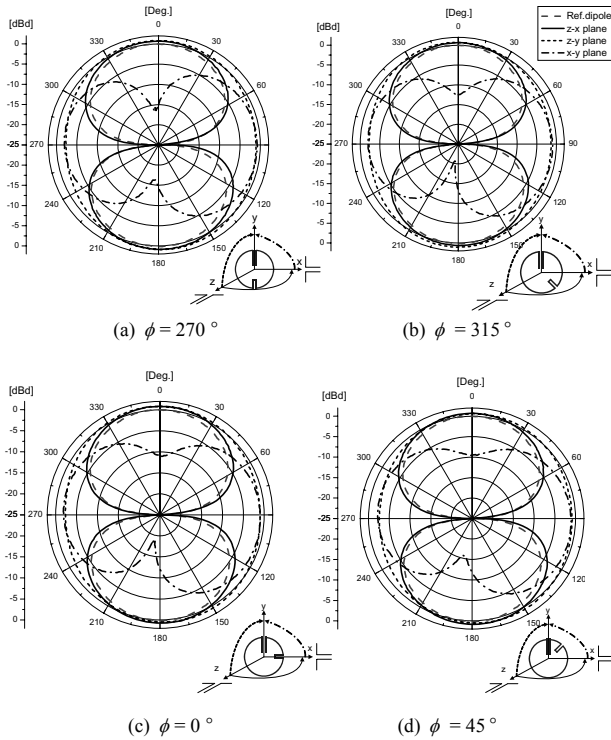

Fig. 6: Radiation patterns according to the position of stub

TABLE 1: CHARACTERISTICS ACCORDING TO THE POSITION OF THE STUB

Position of the stub $\phi$ [Deg.]	Gain [dBd]		HPBW(z-x plane) [Deg.]
	z-x plane	x-y plane	
270	0.68	-0.76	93
315	0.68	-0.98	92
0	0.83	-0.87	93
45	0.71	-1.03	94
Average	0.725	-0.91	93

To verify the change of radiation pattern from the position of the short stubs, prior to miniaturizing the one wavelength CLA, the radiation pattern is measured from  $\phi = 270^\circ$  to  $\phi = 45^\circ$  at an interval of  $\phi = 45^\circ$  varying stub position and Fig.6 and Table 1 show the measurement results of the radiation patterns. As a result, the shape of the radiation pattern is identical. Therefore, the radiation pattern of a miniaturized antenna could be predicted to have no change despite increasing short stubs.

Fig. 7 shows the shift of resonant frequency according to the increasing number of stubs (length of a stub : 20mm). The resonant frequency is decreased linearly by the amount of 295MHz (32%) at 616.25MHz following the number of short stubs, which are 15. For the impedance, the inductance is increased and then the capacitance follows as the current path expands.

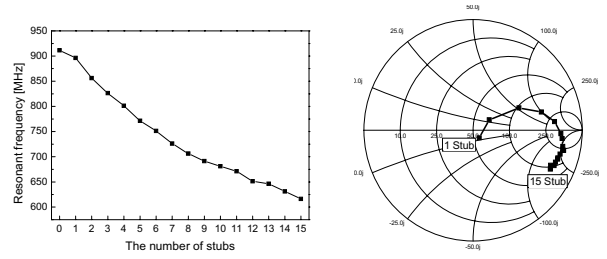

(a) Resonant frequency (b) Impedance(911.25MHz)  
Fig. 7: The characteristics of according to the number of stubs

### C. Small CLAs

Using a method of miniaturizing a loop antenna, two kinds of antennas are designed. In Fig. 8, an antenna is miniaturized with both short stubs of 11.5mm and 7mm located in the loop alternating with each other. The width of the line is 0.3mm and the interval between lines is 0.3mm. It is matched in the length and interval of a series-driven feeding line which is 8mm and 1mm. The diameter of an antenna is miniaturized to 40mm in terms of maximizing a current path inserted with double stubs. The total length of an antenna is  $3.9 \lambda$  (1281mm)

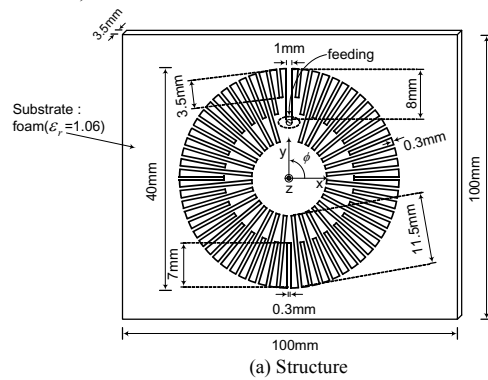

(a) Structure

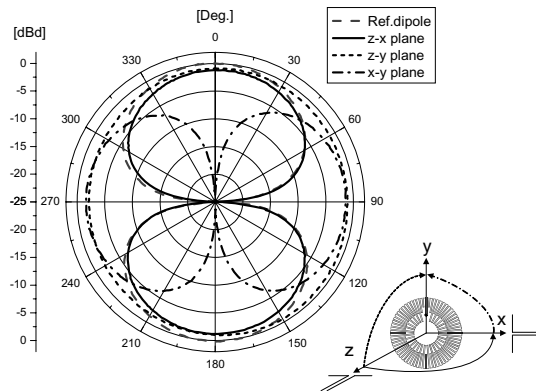

(b) Radiation pattern

Fig. 8: Characteristics of one wavelength CLA

In Fig. 9(a), a half-wavelength structure antenna is illustrated. This can be attached on an edge of some objects which have a characteristic of a conducting plate. For example, snack bags. The coaxial line is used in the feeding of the antenna and its ground area is 200mm×90mm. Also, the antenna has a length of 39mm, and a height of 20mm, using stubs of 10.5mm and 6mm

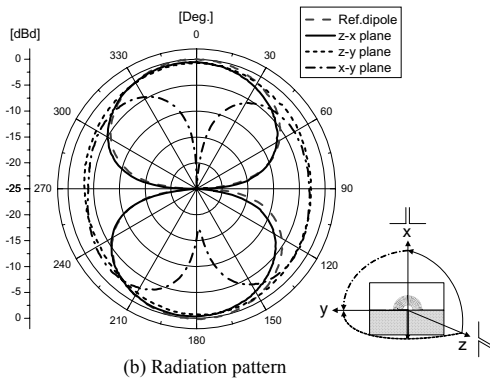
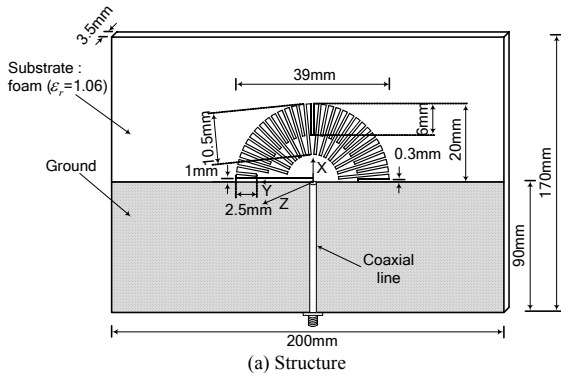

Fig. 9: Characteristics of a half-wavelength CLA

The measured characteristics and radiation patterns of manufactured antennas are shown in table 2 and Fig. 8 and 9. The reduction rate is 83% and 92.1%(except ground), respectively. -10dB bandwidth is 12MHz (1.3%), 48MHz(5%) and the maximum gain of the z-x plane (x-axis pol.) is -1.18dBd, -0.58dBd. Also, the HPBW of the z-x plane (x-axis pol.) is 95° and 87°, respectively. All two kinds of antenna acquired an omni-directional radiation pattern in z-y plane (x-axis pol.). The bandwidth and maximum gain of half-wavelength antenna(Fig. 9(a)) is enhanced due to the effect of its ground.

TABLE 2: COMPARISON OF GENERAL CLA AND MINIATURIZED CLA

	General type	One wavelength structure (Fig.8(a))	Half-wavelength structure (Fig. 9(a))
Resonant freq.[MHz]	911.25		
Diameter[mm]	98	40	39
Size reduction rate[%]	Ref.	83	92.1 (except ground)
Return loss[dB]	-22.5	-11.9	-16.5
-10dB Bandwidth[MHz]	77.46 (8.5%)	12 (1.3%)	48 (5%)
Gain[dBd]	0.33	-1.18	-0.58
HPBW [Deg.]	z-x plane (x-axis pol.)	92	95
	x-y plane (x-y plane pol.)	108	97

### 3. CONCLUSION

In this paper, to make a small-sized RFID tag antenna in the UHF band, the CLA is proposed. In order to match the impedance of CLA, the interval and length between the series-driven feeding are modulated when the series-driven feeding is located inside the loop. Also, it is proposed to increase current length by a short stub located inside the loop. Through this result, we can confirm that miniaturized type CLAs using short stubs are suitable for miniaturized RFID tag antennas with the UHF band.

### ACKNOWLEDGEMENT

This work was supported by grant NO. R01-2003-000-10880-0 from the Basic Research Program of Korea Science & Engineering Foundation.

### REFERENCES

- [1] Klaus Finkenzeller, *RFID Handbook*, Wiley, 2003.
- [2] Chul-Sik Pyo, Jong-Sunk Choi, "RFID Technology and standard", *TTA Journal*, vol. 95, pp. 37-46, 2004.
- [3] King, R, "The Shunt-Driven Circular Loop Antenna", *IEEE Transactions on Antenna and Propagation*, vol. 19, pp. 692-694, Sept. 1971.
- [4] Richard C. Johnson, *Antenna Engineering Handbook*, McGraw-Hill, 2003.
- [5] Hong-Kyun Ryu and Jong-Myung Woo, "Size Reduction in UHF Band RFID Tag Antenna Based on Circular Loop Antenna", *Proceedings of ICEcom2005 Conference*, pp.169-170, Oct, 2005.
- [6] Hong-Kyun Ryu and Jong-Myung Woo, "Miniaturization of Circular Loop Antenna Using Meander Structure for RFID System", *KEES Microwave and Radio Wave Conference*, vol. 28, pp. 271-274 Sept. 2005.
- [7] Constantine A. Balanis, *Antenna Theory Analysis and Design*, Wiley, 1982.