

Performance of RFID Tag at UHF Band in Terms of Radar Cross Sections

Hongil Kwon*, Bomson Lee

School of Electronics & Information, Kyunghee University
 1 Seochun-ri, Kihung-eup, Yongin-si, Kyungki-do, 449-701, Korea
 E-mail : hiluc@paran.com, bomson@khu.ac.kr

1. Introduction

The development of the current Radio Frequency Identification(RFID) systems makes various future applications very promising. If the bar-code systems used in most of the major supermarkets are replaced by RFID tag systems, its impact will be significant as we may imagine. Recently, there has been intense research on RFID tag antennas in the UHF band, especially at 900MHz. Data transfer of passive RFID systems at UHF frequencies is based on backscattering : a tag antenna reflects back a part of the energy received from a reader. In that process, the reflected energy is modulated by the microchip of the tag^[1]. The detection distance is usually determined by measurement as a tag is moved away from a reader antenna. It may be used one of the criteria to evaluate the RFID system including the reader. However, we have some ambiguity in evaluating the performance of RFID tags by their detection distance because the reader systems of different companies have different performances in their detecting capability. We need to have a standard criteria to evaluate the performance of RFID tags in a more quantitative manner based on the same condition. A good way is to monitor the Radar Cross Section (RCS) of tags having specific chip impedances. A RCS can be obtained by impinging a plane wave on a specific object and measuring the backscattered power by simulation or experiment.

2. Tags and Their Evaluation Using RCS

A tag consists of a chip and antenna. One of the important characteristics of the chip is its terminal impedance. By changing the impedance of the chip usually in two states, the RCS of the tag also changes. The digitized information in the chip can be transferred to the reader using this property. This method can be interpreted as a kind of ASK (Amplitude Shift Keying).

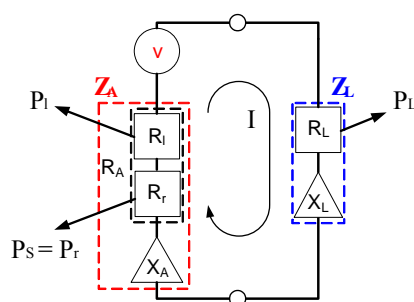

Fig. 1 The equivalent circuit of tag antenna

Fig. 1 shows the Thevenin equivalent circuit of a tag. The voltage V is induced when the tag is hit by the electromagnetic wave radiated from a reader. The chip impedance Z_L is given by $R_L + jX_L$ and the antenna impedance Z_A is given by $R_A + jX_A$ where $R_A = R_r + R_l$. R_r is the radiation resistance corresponding to the total re-radiated(or scattered) power ($P_r = P_s$) and R_l is the resistance corresponding to the loss of the antenna P_l . P_L is the power transmitted to the chip. The effective aperture and the scattering aperture can be shown to be given by equation (2) and (3), respectively, based on the assumption that R_l is negligible and

$Z_L = Z_A^{* [2]-[3]}$ where S is the power density at the tag. The scattering aperture A_s is another name of the radar cross sections (σ).

$$A_e(m^2) = \frac{V^2 \cdot R_L}{S \cdot [(R_r + R_L)^2]} \quad (2) \quad A_s(m^2) = \frac{V^2 \cdot R_r}{S \cdot [(R_r + R_L)^2]} \quad (3)$$

The received power P_r by a reader can be expressed as [4]

$$P_r = \frac{P_t G_t^2 \sigma \lambda^2}{(4\pi)^3 R^4} \quad (W) \quad (1)$$

where P_t = transmitted power. G_t = gain of the transmit (reader) antenna, σ = RCS of a tag, λ = wavelength, and R = distance between tag and reader antenna. As we see in equation (1), P_r is proportional to RCS (σ). The RCS can be determined by EM simulation or by measurement. In EM simulation, a plane wave can be generated to hit the tag in various incidence angles. Then we can obtain the backscattering cross section (or RCS) of the designed tags. It is well known that for a dipole-type tag, the difference of RCS when the chip impedance is 0Ω (short) and that when the chip impedance is matched (about 70Ω) is approximately $6\text{dB}^{[2]}$. This can be verified theoretically or by EM simulation. We have designed a test dipole-type RFID tag (type 1) as shown in Fig. 2. The width and depth of the conductor line are 1mm and 0.018mm , respectively. The overall dimension is $96\text{mm} \times 21\text{mm}$. The antenna is resonant at 911MHz and its resistance R_r is $41(\Omega)$.

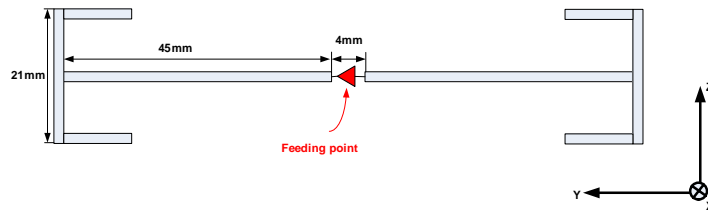
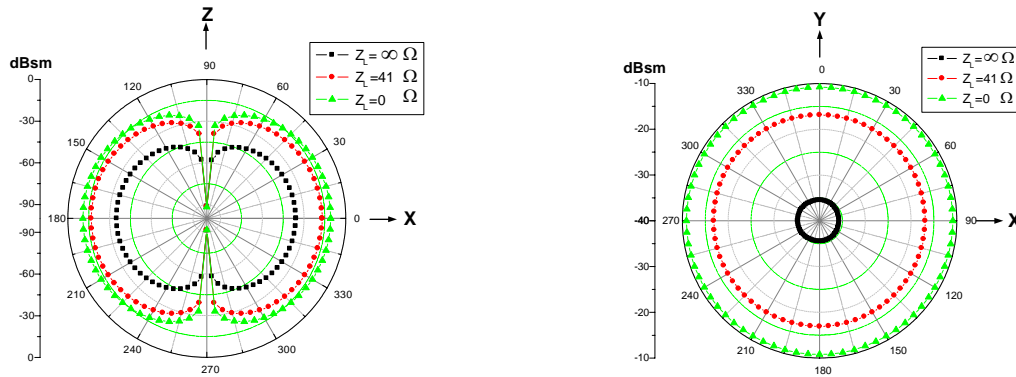

Fig. 2 Geometry of proposed RFID tag antenna (type 1)

Now we want to investigate the RCS of the designed tag changing the chip impedances. A good choice of them would be 0Ω (short), 41Ω (match), and $\infty\Omega$ (open). The bistatic radar cross sections [5] are plotted in Fig. 3(a) (in XZ plane) and Fig. 3(b) (in XY plane). The backscattering cross section (or RCS) is the value in x direction.



(a) $\phi = 0^\circ$ (XZ plane)

(b) $\theta = 90^\circ$ (XY plane)

Fig. 3 Bistatic radar cross sections when a plane wave with $E_y = 1(\text{V/m})$ hits the designed tag

It is -10.9 dBm^2 when $Z_L = 0\Omega$ (short), -16.9 dBm^2 when $Z_L = 41\Omega$ (match), and -35.8 dBm^2 when $Z_L = \infty\Omega$, respectively. We usually choose to use short and matched loads as two states of the chip impedance. The difference of radar cross sections when $Z_L = 0\Omega$ (short) and $Z_L = 41\Omega$ (match) is found to be about 6dB .

We have devised another RFID tag as shown in Fig. 4. We may call it a meandered symmetric PIFA (type 2).

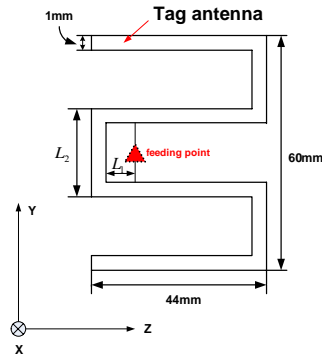

Fig. 4 Geometry of proposed RFID tag antenna (type 2)

The overall dimension is 44mm×60mm. Fig. 5 shows the antenna impedance ($Z_A = R_A + jX_A$) at 911MHz as the feeding point L_1 changes from 10mm to 30mm with $L_2=5$ mm, 10mm, and 20mm, respectively, and with the overall dimension of 44mm×60mm unchanged. It is observed that as L_1 increases, the antenna resistance (R_A) increases and the reactance (X_A) decreases.

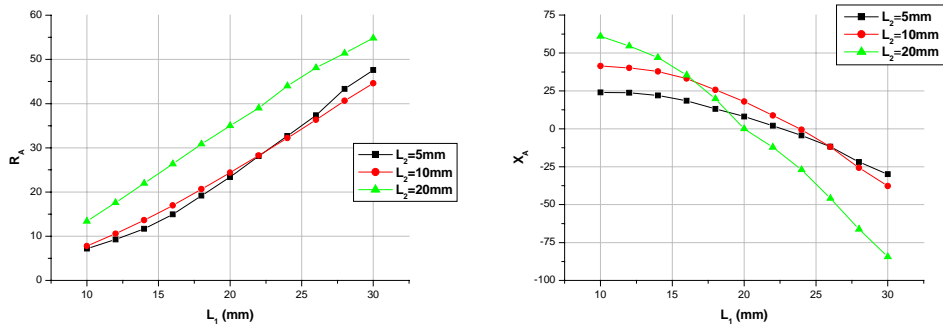

Fig. 5 Antenna impedance($Z_A = R_A + jX_A$) at 911MHz as L_1 changes from 10 to 30mm with L_2 fixed at 5,10, and 20mm, respectively

We choose to use $L_1=L_2=20$ mm and with this choice, the antenna is resonant and its resistance is 35(Ω). The bistatic radar cross sections are plotted in Fig. 6(a) (in XZ plane) and Fig. 6(b) (in XY plane) when $Z_L = 0\Omega$ (short), 35 Ω (match), and $\infty\Omega$ (open). The backscattering cross section is the value in x direction.

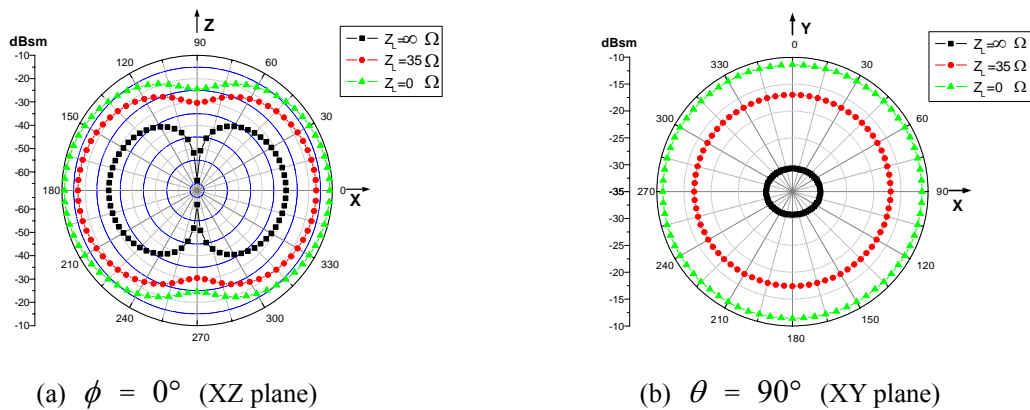

Fig. 6 Bistatic radar cross sections when a plane wave with $E_y = 1$ (V/m) hits the designed tag

It is -11.1 dBm² when $Z_L = 0\Omega$ (short), -17 dBm² when $Z_L = 35\Omega$ (match), and -29.8 dBm² when $Z_L = \infty\Omega$,

respectively. We choose to use short and matched loads as two states of the chip impedance. The difference of radar cross sections when $Z_L=0\Omega$ (short) and $Z_L=35\Omega$ (match) is again found to be about 6dB. It is noted that the detection distance increases as RCS ($Z_L=0\Omega$) and RCS($Z_L=35\Omega$) increase and at the same time the difference of them increases. Fig. 7 shows the radar cross sections as the angle (θ, ϕ) of the incident plane wave changes with respect to the tag.

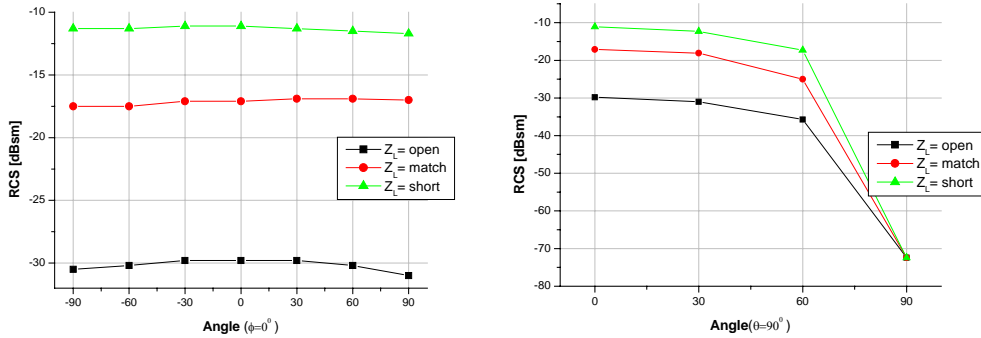

Fig. 7 RCS as incident angles (θ, ϕ) change

The RCS as a function of θ in the $\phi = 0^\circ$ plane are shown not to change significantly for all of the three chip impedances. However, they vary considerably as ϕ changes in the $\theta = 90^\circ$ plane. Especially, we can see that when $\phi = 90^\circ$ and $\theta = 90^\circ$ (when the plane wave is incident in $-Y$ direction), the RCS corresponding to different loads are shown to be almost the same (-73dBm^2) and very small. They may be expected from the given geometry. In this case, we may say that detection by a reader is not possible. The RCS' of tags according to chip impedances (usually short and match loads) give us sufficient information about the tag performance.

III. Conclusion

A dipole-type and a symmetric PIFA at 911MHz have been proposed as RFID tag antenna. Its performance has been shown to be effectively evaluated by the RCS' according to different chip impedances. Evaluation of RFID tags by a detection distance is not a good way since it depends on the reader sensitivity. The proposed new way of evaluating RFID tags by RCS' give us sufficient information about the tag performance and is not dependent on the reader sensitivity.

Reference

- [1] Ukkonen, L.; Sydanheimo, L.; Kivikoski, "Patch antenna with EBG ground plane and two-layer substrate for passive RFID of metallic objects," IEEE Antennas and Propagation Society Symposium, Vol 1, pp 93-96, June 2004
- [2] John D. Kraus, *ANTENNAS*, 2nd ed., McGraw-Hill, Inc., 1988
- [3] Xianming Qing; Ning Yang, "A Folded Dipole Antenna for RFID," IEEE Antennas and Propagation Society Symposium, Vol 1, pp 97-100, June 2004
- [4] KAI CHANG, *RF and Microwave Wireless Systems*, John Wiley & Sons, Inc., 2000
- [5] Akira Ishimaru, *Electromagnetic Wave Propagation, Radiation, and Scattering*, Prentice-Hall, Inc., 1991