

## A COMPACT DUAL-BAND ANTENNA FOR GPS/ DCS

Shun-Yun Lin  
 Department of Electrical Engineering  
 Cheng Shiu University, Kaohsiung, Taiwan, R.O.C.  
 Email: [yun@csu.edu.tw](mailto:yun@csu.edu.tw)

### 1. Introduction

Mobile communications have been indispensable in modern life. There are various communication systems implemented to meet different needs. Among the systems, the GPS system provides global positioning function via satellites; and the DCS system provides personal mobile communication services [1-2]. This paper presents a compact dual-band antenna for GPS/DCS systems. However, because of the differences of the radiation performances for GPS and DCS, conventional dual-band antennas which are with the same radiation characteristics for both operating modes are not suitable in the GPS/DCS applications [3-4]. This design consists of an annular ring patch and a truncated square patch antenna. The truncated square patch, used as a GPS antenna, is put within the annular ring patch and excited two degenerated modes to obtain circular polarization. A substrate with high permittivity is selected to make the square patch more compact to fit in with the inner radius of the annular ring. On the other hand, a new design [5] of a  $TM_{21}$  mode annular ring patch antenna with slotted ground is used for the application of DCS. The both antennas occupy the same space but operate independently. This study presents an integral compact antenna for dual-band operation. Details of the experimental results and an equation to estimate the lowered resonant frequency for the constructed prototypes are presented.

### 2. Antenna Design

The configuration of the proposed antenna is shown in Fig. 1. The truncated square patch antenna, offers a right-hand circular polarization radiation, is well known. The annular ring radiation patch with outer radius  $R_1$  and inner radius  $R_2$  operates at  $TM_{21}$  mode. The resonant frequency of the annular ring patch antenna with regular ground plane can be calculated according to the following equation [6]:

$$w / R = 0.4 \dots\dots\dots(1)$$

$$k \times R = 2 \dots\dots\dots(2)$$

where,  $k = 2\pi/\lambda_0$ ;

$$w = (R_1 - R_2) / 2;$$

$$R = (R_1 + R_2) / 2$$

In order to make the patch size of the annular ring more compact, four radial slots are embedded on the square ground plane [5]. The resonant frequency of  $TM_{21}$  mode is about linearly decreased with the increasing slot length, and can be estimated by the following equation:

$$f_c = f_0 - 19.4 \times L_s \dots\dots\dots(3)$$

Where,  $f_c$  represents the resonant frequency of the annular ring patch with slotted ground plane, and  $f_0$  represents that of regular ground plane. Table I lists the performances of the annular ring patch antenna with embedded slots in the ground plane. The data indicate that the equation (3) can well predict the resonant frequency of an actual antenna. Moreover, the great patch size reduction accompanies with the noticeable enhancement of impedance bandwidth. This characteristic is so different from the conventional compact design. Furthermore, for applications in which a large F/B ratio is preferred, a conducting plate can be added behind the antenna's ground plane to reflecting or blocking the backward radiation.

### 3. Experimental Results and Discussion

Fig.2 (a) shows that the impedance bandwidth for VSWR 2.0 is 24 MHz (1568 MHz - 1592 MHz) for GPS antenna.. Also, the measured radiation performances indicate that the CP bandwidth is of about 8MHz. In addition, Fig. 2 (b) indicates that the impedance bandwidth is 175 MHz for DCS (1705 MHz - 1880 MHz, 9.8%). The large enhancement is probably caused by the embedded radial slots, which lower the quality factor of the proposed DCS antenna. Fig.3 demonstrates the measured isolation between the two feeding ports. The isolation is about -20 dB around the GPS band, and less than 40 dB for other band. These characteristics indicate that each antenna could operate correctly without significant perturbation from the operation of the other one. The radiation patterns are also investigated. Fig. 4(a) depicts the patterns of the GPS antenna. The results show that the truncated square patch antenna with high permittivity operates with RHCP pattern at 1575, which meets the requirement of the GPS system. Fig. 4(b) illustrates the radiation pattern of the DCS antenna. The conical patterns in the x-z and y-z planes indicate that an omnidirectional radiation occurs in the azimuthal plane. This mono-polarized feature makes the high-order patch antenna suitable for mobile communication.

Table I. Measured and simulative resonant frequency of  $TM_{21}$  mode Annular-ring patch antenna with slotted ground plane. The outer radius  $R_1$  and inner radius  $R_2$  are 47 mm and 19.5 mm. The height of air substrate and the width of the slots are 3 mm and 2 mm, respectively.

$L_s$ mm	w mm	$f_r$ , simulative MHz	$f_r$ , calculated MHz	Compact ratio %	BW MHz, %	Max. gain dBi	F/B ratio (dB)
0	-	2872	2840	-	80, 2.8	5.9	12.4
15	2	2581	2660	12.3	70, 2.6	5.8	10.4
30	2	2290	2295	34.7	110, 4.8	4.7	6.0
40	2	2096	2045	48.1	115, 5.6	4.2	4.3
50	2	1902	1880	56.2	120, 6.4	3.9	2.3
60	2	1708	1735	62.7	190, 11.0	3.6	2.0
75	2	1417	1470	73.2	200, 13.6	3.7	1.3

### 4. Conclusion

This paper presents the propose and analysis of a dual-band patch antenna for the application of GPS and DCS. By using high permittivity substrate and slotted ground plane, a compact design is achieved. In this study, a truncated square patch is selected to be a GPS antenna. Its operating frequency of 1575 MHz and circular polarization bandwidth of 8 MHz are obtaine to meet the requirements of the GPS. Also, the perfromances of  $TM_{21}$  mode and impedance bandwidth of 9.8% make the proposed annular-ring patch antenna suitable for mobile communication of DCS.

### References

- [1] H. O.hmine, Y. Sunara, M. Matsunaga, "An annular-ring microstrip antenna fed by a co-planar feed circuit for mobile satellite communication use," *IEEE Trans. Antennas Propagat.*, vol. 45, pp. 1001-1008, 1997.
- [2] N. Padros, J. I. Ortigosa, J. Baker, M. F. Iskander, B.Thornberg, "Comparative study of high-performance GPS receiving antenna design," *IEEE Trans. Antennas Propagat.*, vol. 45, pp. 698-706, 1997.
- [3] J. Ollikainen, M. Fischer, and P. Vainikainen, "Thin dual-resonant stacked short patch antenna for mobile communication," *Electron. Lett.*, vol. 35, pp. 437-438, March 1999.
- [4] K. Fujimoto, A. Henderson, K. Hirasawa, and J. R. James, *Small Antennas*. New York: Wiely, 1987.
- [5] S. Y. Lin and K. L. Wong, "Enhanced performances of a compact conical-pattern annular-ring patch antenna using a slotted ground plane," *Proc. 2001 Asia-Pacific Microwave Conf.*, pp. 1036-1039.
- [6] Y. S. Wu, and F. J. Rosenbaum, "Mode chart for microwave ring resonantors," *IEEE Trans. Microwave Theory and Tech.*, vol. 21, pp. 487-489, 1973.

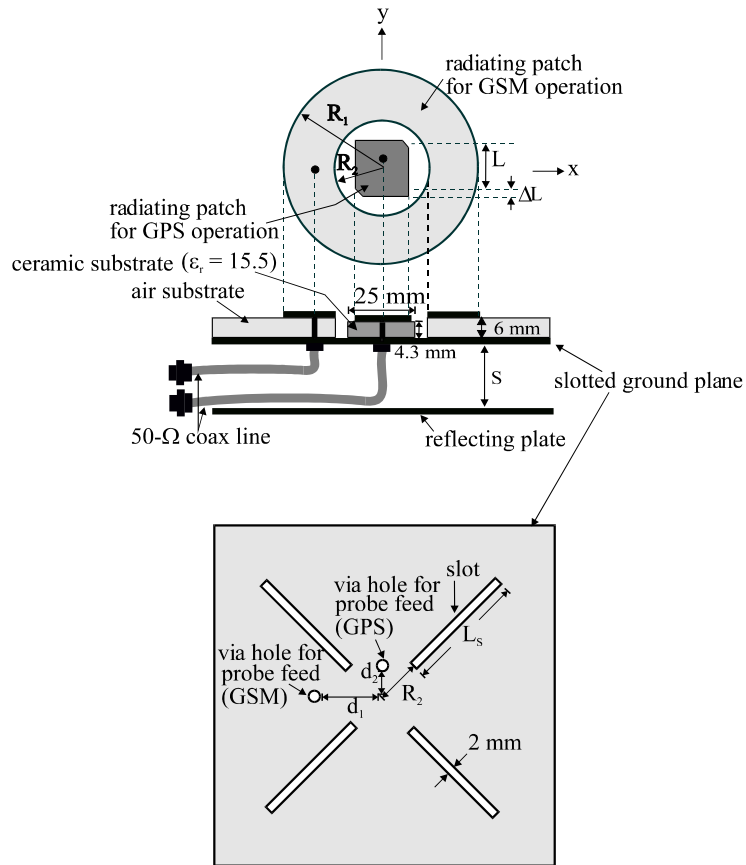

Fig. 1 Configuration of a compact GPS/GSM dual frequency patch antenna with integrating structure;  $L = 21.4$  mm,  $\Delta L = 2.2$  mm,  $R_1 = 52.5$  mm,  $R_2 = 22$  mm,  $S = 12$  mm,  $L_s = 60$  mm,  $d_1 = 38$  mm,  $d_2 = 3.38$  mm, ground plane =  $180 \times 180$  mm<sup>2</sup>.

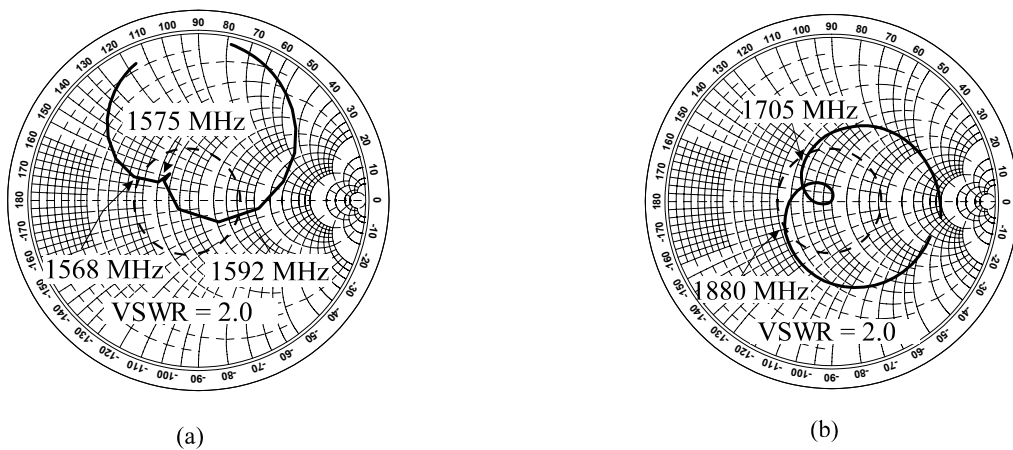

Fig. 2 (a) Measured input impedance on a Smith chart for GPS antenna. (b) Measured input impedance on a Smith chart for GSM antenna.

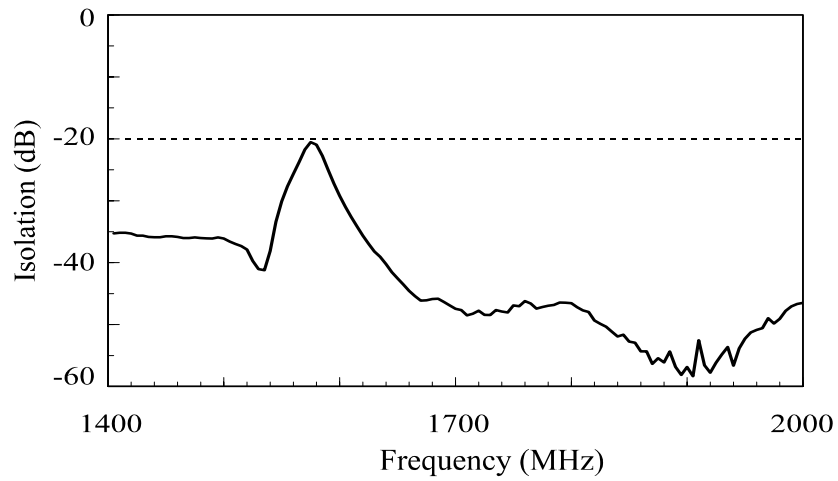

Fig. 3 Measured isolation between the feeding points of GPS and GSM antennas.

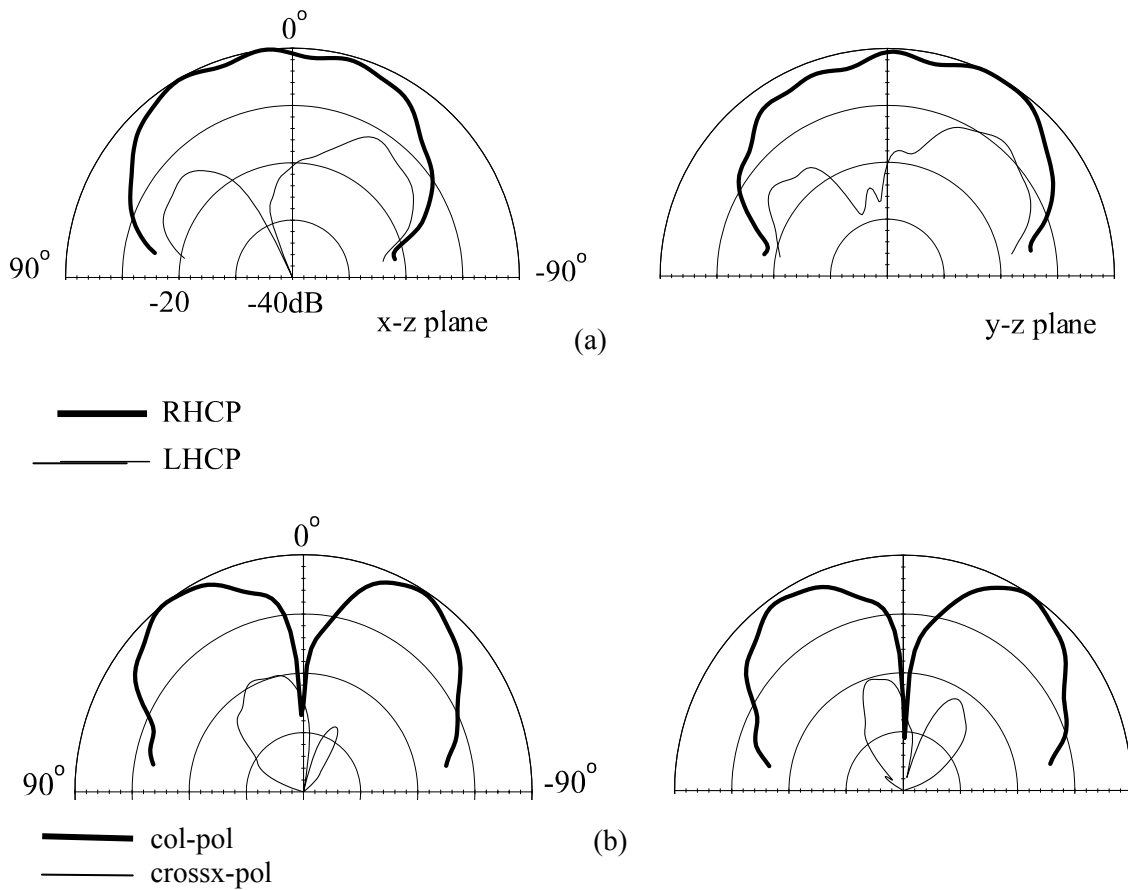

Fig. 4 (a) Measured radiation patterns for GPS antenna at 1575 MHz. (b) Measured radiation patterns for GSM antenna at 1800 MHz