

EFFECT OF DIMENSION OF CONDUCTING BOX ON RADIATION PATTERN OF A MONOPOLE ANTENNA FOR PORTABLE TELEPHONE

Ryo Yamaguchi[†], Kunio Sawaya[†], Yoshiyuki Fujino[‡] and Saburo Adachi[†]

[†]*Department of Electrical Engineering, Tohoku University, Sendai, 980, Japan*

[‡]*Communications Research Laboratory, Koganei, Tokyo, 184, Japan*

I. INTRODUCTION Recently, the demand of mobile communications such as the car telephone and the portable telephone has increased rapidly. Monopole antenna and built-in type antennas such as an inverted planer F-shaped antenna are mostly commonly used for portable telephone[1]. Since these antennas induce a surface current on the conducting box strongly and the radiation from the box can not be ignored, the dimensions of the box are considered to affect the characteristics of antenna. For example, it has been pointed out that the radiation pattern of an antenna mounted on the box tends to tilt toward a lower direction by some experiments[2]. However, the relation between the radiation pattern and the dimension of the conducting box has not been reported theoretically. In this report the effect of the dimension of the conducting box on the radiation is described. As an example of antenna for the portable telephone, we employ the quarter-wavelength monopole antenna having a sinusoidal current distribution. Several methods for the analysis of an antenna in the vicinity or mounted on a conducting box have been used. The wire-grid method, which replaces the conducting surface with a wire mesh, is simple method[3]. A Galerkin-moment method analysis using a Fourier series expansion of the surface current of the conducting box requires a complicated formulation of the elements of the impedance matrix. However, it has an advantage of a higher accuracy than other methods[4],[5]. Therefore, we employ the Galerkin-moment method in this report.

II. GEOMETRY AND METHOD OF ANALYSIS The geometry of a monopole antenna mounted on a top of a conducting box is shown in Fig.1. Surface current on #1-#6 planes (Fig.1(b)) of the box is expanded with Fourier series, e.g., the surface current on #1 and #4 is expanded by using a basis function given by

$$J(m_i, n_i, x, y) = \frac{1}{\sqrt{ab}} e^{j(\frac{m_i \pi}{a} x + \frac{n_i \pi}{b} y)} \quad (1)$$

where m_i and n_i are mode numbers of the basis functions on the plane #1 and #4 as shown in Fig.1(c). Applying the Galerkin-moment method and using the basis and the test functions given by Eq.(1), an electric field integral equation is converted into a matrix equation. Since our interest is focused on a radiation pattern of a quarter-wavelength monopole antenna, we assume a sinusoidal current distribution on the monopole antenna. The voltage vector in the matrix equation is calculated by taking an inner product between the test function and the incident field which is generated by the sinusoidal current. Although there are 12 types the elements of the voltage vector (2 directions and 6 planes), only 4 fundamental types of the elements are necessary as shown in Table 1. The other 8 types of elements are easily obtained by using a coordinate transformation. By using the procedure described above, the surface current of the conducting box can be numerically calculated and the radiation pattern is obtained.

III. RADIATION PATTERN

The radiation pattern of the monopole antenna shown in Fig.1 having the quarter-wavelength is calculated. The dimension of the conducting box and the location of the monopole antenna used for calculations are summarized in Table 2. Fig.2 shows the theoretical radiation pattern in yz plane with experimental data, where the value of the radiation field is normalized as 0 dB by the maximum level. Good agreement between the theory and the experiment is observed confirming the validity of the present analysis. It is noted that a beam tilt toward a lower direction is observed and the relative radiation level of the horizontal direction decreases. The theoretical radiation pattern with varying the values of the width a and the thickness b of the conducting box is shown in Fig.3. When the width a or the thickness b is changed, the horizontal level is much affected. However, the direction of the beam is not much affected.

Fig.4 illustrates the effects of the height c of the conducting box. As the height c increases, the number of ripples increases and the main beam goes to lower direction, where a sufficient horizontal gain can not be obtained. When height c is less than $\lambda/4$, the main beam direction is close to the horizontal direction, and the beam width becomes wide. In this figure, the radiation field by the box and that of the monopole antenna are shown separately. It is noted that the level of radiation from the box is comparable to that from the monopole antenna. The theoretical and experimental results of the direction of the beam in yz plane versus the height c of the box is shown in Fig.5. Good agreement between the theory and the experiment is again observed.

IV. CONCLUSION Effect of dimension of a conducting box on a radiation pattern of a monopole antenna has been analyzed by using the Galerkin-moment method with Fourier series expansion. It has been shown that the beam tilts towards lower direction and the horizontal level decreases as the height of the conducting box increases. Good agreement between the theory and the experiment has been observed, confirming the validity of the analysis.

REFERENCES

- [1] H.Haruki, A.Kobayashi, "Inverted Planer F-Shaped Antenna for Portable Telephone", *National Conv. Rec. IECE Japan*, 613, Mar. 1982.
- [2] K.Suda, K.Sawaya, K.Igari and S.Adachi, "S-Shaped Antenna for Portable Telephone", *Trans. IEICE Japan*, Vol.71-B, No.11, pp.1365-1367, Nov. 1988.
- [3] K.Hirasawa, K.Fujimoto, "Characteristics of a Wire Antenna Attached to a Conducting Rectangular Box", *Trans. IECE Japan*, Vol.J65-B, No.9, pp.1133-1139, Sep. 1982.
- [4] T.Kurioka, K.Sawaya and S.Adachi, "Analysis of a Slot Antenna on a L-Shaped Conducting Plane using Fourier Series Expansion and Galerkin-Moment Method", *Trans. IEICE Japan*, Vol.J71-B, No.11, pp.1386-1388, Nov. 1988.
- [5] Y.Fujino, K.Sawaya and S.Adachi, "Analysis of a Slot Antenna on a Three-Dimensional Rectangular Conductor using Fourier Series Expansion and Galerkin-Moment Method", *Trans. IEICE Japan*, Vol.J72-C-I, No.11, pp.781-786, Nov. 1989.
- [6] R.Yamaguchi, Y.Fujino, K.Sawaya and S.Adachi, "The Effects of the Dimensions for the Directivity of a Monopole Antenna on the Conducting Box", *Tech. Rept., IEE Japan*, EMT-91-80, pp.41-47, Oct. 1991.

Table 1 Fundamental 4 elements of voltage vector.

Element	Surface	Polarization of incident field
$V_{1x}(m_i, n_i)$	#1	x-direction
$V_{1y}(n_i, m_i)$	#1	y-direction
$V_{2y}(p_i, q_i)$	#2	y-direction
$V_{2z}(q_i, p_i)$	#2	z-direction

Table 2 Dimensions of box and monopole antenna used for calculations.

Dimension of box	a	0.3λ (60 mm)
	b	0.05λ (10 mm)
	c	0.515λ (130 mm)
Length of monopole	h	0.25λ (50 mm)
Radius of monopole	r_0	0.0025λ (0.5 mm)
Location of monopole antenna	a_0	$a/2$
	b_0	$b/2$
Modes included in calculations	m_i, n_i	
	p_i, q_i	-3,-2,-1,0,1,2,3
	s_i, t_i	

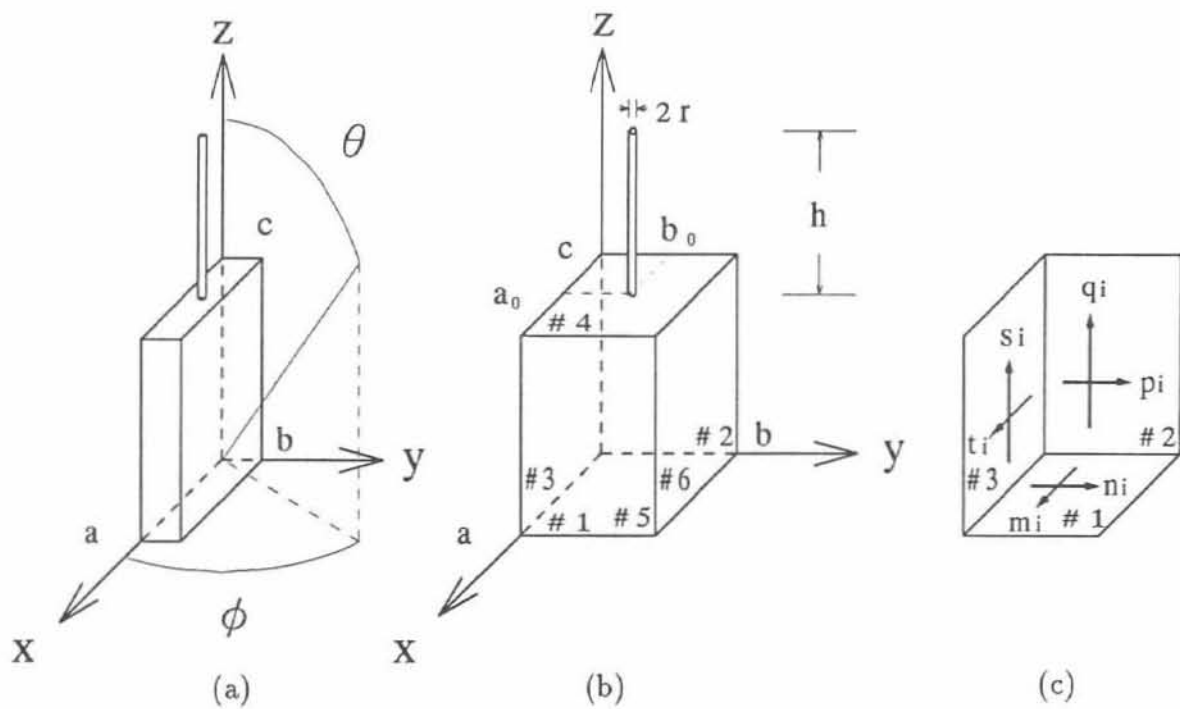

Fig.1 Geometry of monopole antenna and coordinate system.

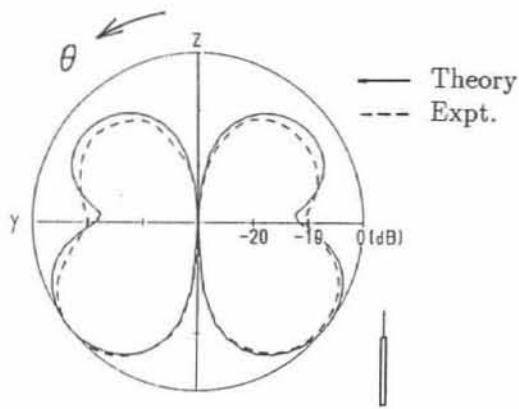

Fig.2 Radiation pattern of monopole antenna.
 E_θ in yz plane ($\phi=90^\circ$).

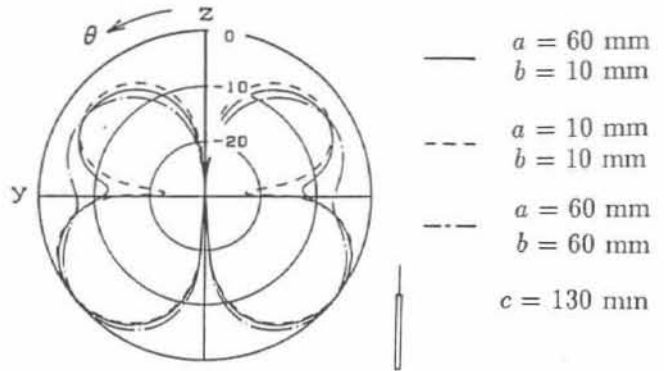

Fig.3 Radiation pattern with varying the width a and the thickness b of the conducting box.
 E_θ in yz plane ($\phi=90^\circ$).

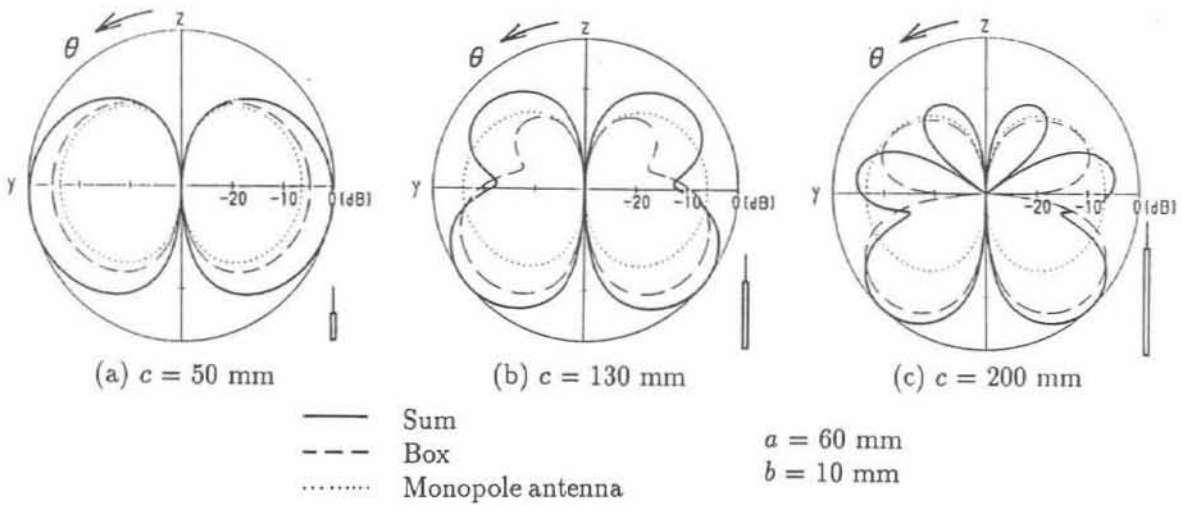

Fig.4 Radiation pattern with varying the height c of conducting box.
 E_θ in yz plane ($\phi=90^\circ$).

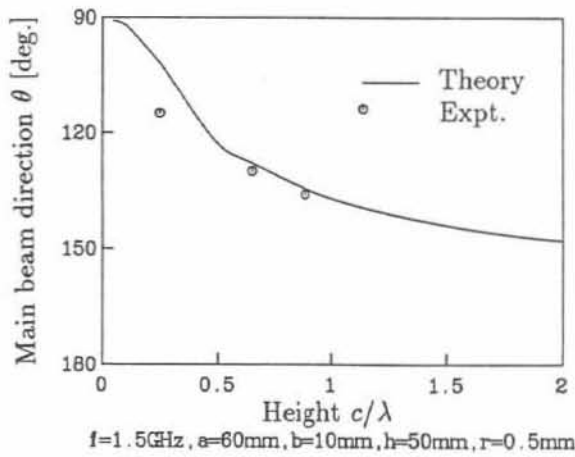

Fig.5 Direction of main beam in yz plane versus height of conducting box.
 E_θ in yz plane ($\phi=90^\circ$).