

# Expectation for Metamaterials for Antenna Applications

Naobumi Michishita

Department of Electrical and Electronic Engineering, National Defense Academy  
1-10-20 Hashirimizu, Yokosuka, 239-8686 Japan

**Abstract** - Metamaterials are strongly expected to be useful for antenna miniaturization and high functionality. The composite right/left-handed transmission line theory has been proposed to expand to the left handed region. As a result, the degree of freedom of antenna design is enhanced and novel antenna can be achieved. In this paper, the metamaterial technologies are explained as three fields of the application. In addition, the research and development in future are shown in each application.

**Index Terms** — Metamaterials, Small antennas, Leaky wave antennas, Artificial magnetic conductors, Multi-layer ceramic capacitors.

## 1. Introduction

Electromagnetic field in a material, in which both the permittivity and permeability simultaneously becomes negative, has been theoretically considered in 1968 [1]. After that, an artificial material was called as metamaterial, and the phenomenon of negative refractive index using a left-handed material has been demonstrated in 2000 [2]. Metamaterials are strongly expected to be useful for antenna miniaturization and high functionality. The composite right/left-handed (CRLH) transmission line theory has been proposed to expand to the left handed region [3]. As a result, the degree of freedom of antenna design is enhanced and novel antenna can be achieved. In recent years, novel possibilities have been shown such as transformation electromagnetics, non-foster element, non-reciprocal circuit [4].

To consider the future of the antenna, the application, simulation, and material are important points [5]. To develop the antennas for various applications at high frequency band in future, the metamaterial will become an essential technology in order to meet required specifications. To do that, a systematic antenna design method becomes effective such as the characteristic mode analysis [6]. An increased role of metamaterials is expected as the antenna element or the antenna surrounding medium. In this paper, the metamaterial technologies are explained as three fields of the application. In addition, the research and development in future are shown in each application.

## 2. Classification of metamaterial antennas

Metamaterial antennas can be classified as shown in Table I. The antenna element means the application of metamaterials to the transmission line composing the

antenna. This application can be divided into resonant and non-resonant types. The antenna surrounding medium can improve the antenna characteristics by arranging the metamaterial surrounding the conventional antennas. The antenna material means uses the metamaterial as a base material for the conventional antennas.

TABLE I  
Classification of metamaterial antennas

Application	Type		Features
Antenna element	Resonant	Radiation element	Small
		Parasitic element	Mutual coupling reduction
	Non-resonant		Broadband
Antenna surrounding medium	Electromagnetic bandgap structure		Coupling reduction
	Artificial magnetic conductor		Low-profile
	Negative refractive index lens		Thin and small

## 3. Application to antenna element

Since the dispersion characteristics can be designed through the metamaterial technology, the resonant-type metamaterial antenna can achieve the miniaturization of the antenna size. This is because the resonance in the left-handed band occurs at low frequency band. To obtain the left-handed branch, the series capacitance and shunt inductance are implemented. The transmission lines actually used are coaxial line, parallel line, microstrip line, coplanar waveguide, parallel plate waveguide, and waveguide.

A resonant phenomenon at the frequency of  $\beta = 0$  is called as the zeroth order resonance in particular [7]. The wavelength becomes infinite due to constant phase over the whole resonator. Therefore, the zeroth order resonator is promising as a miniaturization technique of the antenna. In addition, the antenna with no phase variation can allow the installation space of the antenna becomes very thin and large area, or slender area.

The leaky wave antenna composed of the CRLH transmission line has the feature of broadband and the beam scanning capability by varying the operational frequency. To achieve high gain in the case of the handset antennas, two unit cell composed of the mushroom structure has been proposed as shown in Fig. 1 [8]. The antenna characteristic is varied by terminal conditions. In the case of the shunt

condition, the bandwidth becomes 106%, and the realized gain becomes more than 2.1 dBi within the operating frequency band.

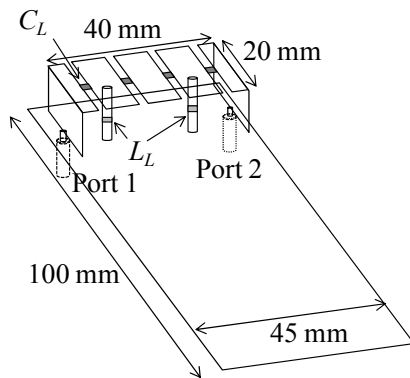

Fig. 1. Small broadband handset antenna.

#### 4. Application to antenna surrounding medium

The electromagnetic bandgap (EBG) structures have been employed for realizing low profile antenna, mutual coupling reduction, gain enhancement, bandstop filter, and so on. Since the EBG structure can be fabricated with antenna element by the manufacturing method of print circuit board, the improvement of the antenna characteristic can be easily achieved. Another feature of the EBG structure is the in-phase reflection, and is called as artificial magnetic conductor (AMC). When the AMC reflector is used as the antenna reflector, low profile and high gain can be achieved. In addition, very thin wave absorber composed of the mushroom structure on the FR-4 substrate has been investigated [9]. The metasurface can achieve a stable operation for absorbing frequency at oblique incident angles more than 30 degrees.

#### 5. Application to antenna material

To achieve low loss metamaterial at high frequency band, the dielectric resonator-based metamaterial has been proposed [10]. Furthermore, a new level set-based topology optimization method has been also proposed for designing the dielectric resonator-based metamaterial [11]. In the proposed method, the shape and topology of the dielectric resonators are represented by the level set function, and topology optimization problems are formulated on the basis of the level set-based representation. When the dielectric metamaterial is used as a lens antenna, the negative refractive index lens with thin, small, and wide angle scanning can be achieved. However, the three dimensional and simple metamaterial structure needs to be developed for a limited dimension in the case of small antennas.

A small antenna covered with epsilon negative shell can exceed an antenna miniaturization limit through electromagnetic simulation [12]. To realize that, the homogeneous and non-dispersive metamaterial should be developed. On the other hand, the left-handed metamaterial structure composed of multi layer ceramic capacitor has been proposed in order to realize the small unit cell configuration [13]. The various metamaterial antennas such as slender and

low profile configuration has been shown. However, the appropriate feeding method, the increase of radiation resistance, or optimum cell arrangement should be investigated in future.

#### 6. Conclusion

This paper presents the metamaterial technologies for antenna applications with the research and development in the past, the present, and the future. The metamaterial study shifted from the discovery of a novel electromagnetic phenomenon to the suggestion of the practical use antenna. The recent progress of terahertz or optical metamaterial studies is also remarkable. In addition, the multi-physics analysis with heat transfer, a fluid, structure, or the acoustic metamaterials will shift to the next stage. Metamaterials are strongly expected to be useful for the future of the antenna.

#### References

- [1] V.G. Veselago, "The electrodynamics of substances with simultaneously negative values of  $\epsilon$  and  $\mu$ ," *Sov. Phys. Usp.*, vol. 10, no.4, pp. 509-514, Jan.-Feb. 1968.
- [2] D.R. Smith, W.J. Padilla, D.C. Vier, S.C. Nemat-Nasser, and S. Schultz, "Composite medium with simultaneously negative permeability and permittivity," *Phys. Rev. Lett.*, vol. 84, no.18, pp. 4184-4187, May 2000.
- [3] C. Caloz and T. Itoh, *Electromagnetic Metamaterials: Transmission Line Theory and Microwave Applications*, Wiley-Interscience, 2005.
- [4] A. Sanada, "Recent advancement of metamaterials," *IEICE Commun. Society Mag.*, no.33, pp.6-11, June 2015 (in Japanese).
- [5] H. Arai, "Future of antenna technologies," *IEICE Commun. Society Mag.*, no.19, pp.198-202, March 2012 (in Japanese).
- [6] R. Harrington, J. Mautz, "Theory of characteristic modes for conducting bodies," *IEEE Trans. Antennas Propagat.*, vol.19, no.5, pp.622-628, Sep. 1971.
- [7] A. Sanada, C. Caloz, and T. Itoh, "Novel zeroth-order resonance in composite right/left-handed transmission line resonators," *Asia-Pacific Microw. Conf.*, Seoul, Korea, pp.1588-1592, Nov. 2003.
- [8] N. Michishita, H. Kitahara, and Y. Yamada, "Small broadband handset antenna using composite right/left-handed transmission line," *IEICE Trans. Commun. (Japanese Edition)*, vol. J95-B, no.9, pp.1060-1068, Sep. 2012.
- [9] J. Shinohara, N. Michishita, Y. Yamada, and H. Hada, "Thin wave absorber composed of mushroom structures," *IEEE AP-S Int. Symp.*, 402.7, pp.1-2, Chicago, IL, July 2012.
- [10] T. Ueda, A. Lai, and T. Itoh, "Negative refraction in a cut-off parallel-plate waveguide loaded with two-dimensional lattice of dielectric resonators," *36th Eur. Microw. Conf.*, pp 435-438, Manchester, U.K., Sep. 2006.
- [11] S. Yamasaki, T. Nomura, K. Sato, N. Michishita, Y. Yamada, and A. Kawamoto, "Level Set-based Topology Optimization Targeting Dielectric Resonator-based Composite Right- and Left-handed Transmission Lines," *Int. J. Numerical Methods Eng.*, vol.89, no.10, pp.1272-1295, March 2012.
- [12] R.W. Ziolkowski and A. Erentok, "Metamaterial-Based Efficient Electrically Small Antennas," *IEEE Trans. Antennas Propagat.*, vol.54, no.7, pp.2113-2130, July 2006.
- [13] N. Michishita and H. Morishita, "Metamaterial Structures Composed of Multi-Layer Ceramic Capacitors for Antenna Applications," *45th Eur. Microw. Conf.*, pp.1327-1330, Paris, France, Sep. 2015.