

Active and Passive Aperture Coupled Microstrip Antenna Design

#M.K.A Rahim, Z.W Low, P.J.Soh, A. Asrokin, M.H. Jamaluddin, M.R. Ahmad

Wireless Communication Centre (WCC)
Faculty of Electrical Engineering
Universiti Teknologi Malaysia
81310 UTM Skudai
Johor Malaysia

Email: mkamal@fke.utm.my, zhiwei82@gmail.com, sohpingjack@gmail.com, awi1982@yahoo.com, haizal@fke.utm.my, riduan@ieee.org

Abstract

Microstrip antennas has a few feeding technique applicable to them. One of them is the non-contacting feeds, which is the aperture-coupled feed techniques. The main mechanism of power transfer between its feed line and patch is the coupling mechanism through the aperture. This work is an effort to design, simulate, fabricate and measurement of passive and active rectangular patch with aperture coupled feed techniques. Simulation is being done using the Method of Moments (MoM). This is simulated in Microwave Office software. This design intends to focus on studying the differences in simulated and measured parameters of the antenna on its return loss, bandwidth and radiation pattern..

I. INTRODUCTION

The wireless industry has experienced a significant growth in the past several years. There is an essential need for a light weight with a low profile and a good performance antenna for wireless application. In order to meet these demands, printed circuit patch antenna is one of the solutions to it. There are four feedings for microstrip antenna which can be categorized in contacting feed and non-contacting feed. For contacting feed, there are microstrip feed and coaxial feed while non-contacting feed are proximity feed and aperture coupled feed. However, for microstrip feed and coaxial feed, these antennas are characterized by bandwidth limitation, which is about 1-2% [1]. To overcome this problem, aperture coupled microstrip antenna is discovered by the researchers for the purpose to improve antenna performance features such as bandwidth. Their features have met the essential need for wireless application which requires a light weight with a low profile

and a good performance antenna. The structure consists of two substrates, one containing the radiating patch and other containing the feed network [2]. A small aperture located under the patch allows coupling of the patch to the feed line which has the form of an open-circuited stub [3]. The input impedance can be controlled by its size, position, and shape of the aperture and open-ended stub length. Besides that, its performance will also affected by the type of the antenna which comprise of active or passive. In this paper, the aperture coupled microstrip antenna for active and passive are investigated in terms of its return loss, bandwidth and radiation pattern. The antenna structure has been design at 2.4 GHz frequency.

II. ANTENNA STRUCTURE AND DESIGN

The main objective of this work is to design the active aperture coupled microstrip antenna to resonate at the frequency of 2.4 GHz. Since a suitable and similar substrate must be chosen in order to provide a general platform for the shapes to be simulated, the chosen substrate is FR-4, which has a dielectric constant (ϵ_r) of 4.5, dielectric loss tangent ($\tan\delta$) of 0.019 and substrate height (h) of 1.6mm.

The first design is the active aperture coupled microstrip antenna. The patch of the antenna is calculated based on the equation in [4] and the dimension is adjusted for optimization. For the calculated patch, the dimension is 37.7 mm for the width and 29.1 mm for the length but after optimization the patch for the width is 38 mm for the width and 28 mm for the length. This design is according to the normal feed width in FR-4 for 50 ohm microstrip line which is 3 mm. The feed line has a width and length of 3mm x 57.5mm starting from the stub, where 28 mm of the length is overlapped under the ACMA patch. The antenna's full dimension is shown in Fig. 1 and the schematic of the active

antenna is shown in Fig. 2. The schematic of the active antenna is using the transmission line circuit simulator from Microwave office software. The capacitor chosen for the dc block is 100 pF. The current for the transistor is biased at 40 mA.

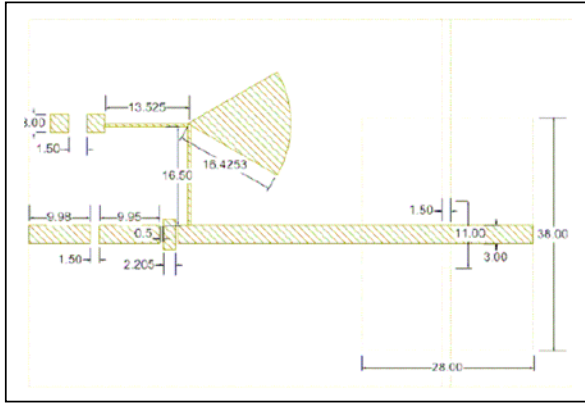

Fig. 1: Dimension of active aperture coupled microstrip antenna

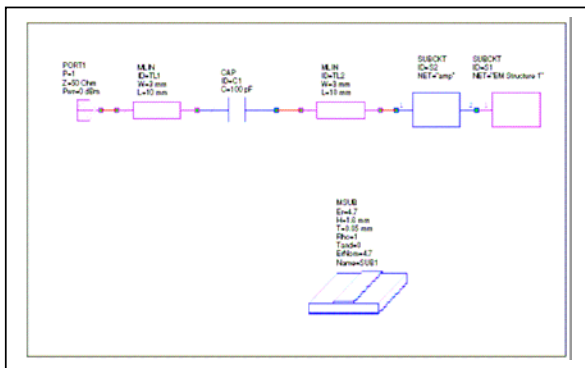

Fig. 2: Schematic view of active aperture coupled microstrip antenna

Fig. 1 shows the radial stub used for the amplifier biasing. The biasing voltage is depend on the amplifier data sheet. Fig. 2 shows the schematic diagram using microstrip line and capacitor with 100 pF. The following is the microstrip line connecting the ERA-2sm amplifier from mini-circuit and the right most ended is the ACMA. All the microstrip line in the active antenna design is in 3 mm wide except the stub line is using only 1 mm wide feed line.

The passive aperture coupled microstrip antenna and the dimension for the antenna is fixed except the feed line width for the comparison purpose. The overall dimension for the feed line of the passive ACMA is 8 mm x 57.7 mm. Its patch is 37 mm x 28 mm while the aperture slot is in 11 mm x 1.5 mm. The full dimension for the passive aperture coupled microstrip antenna is shown in Fig. 3.

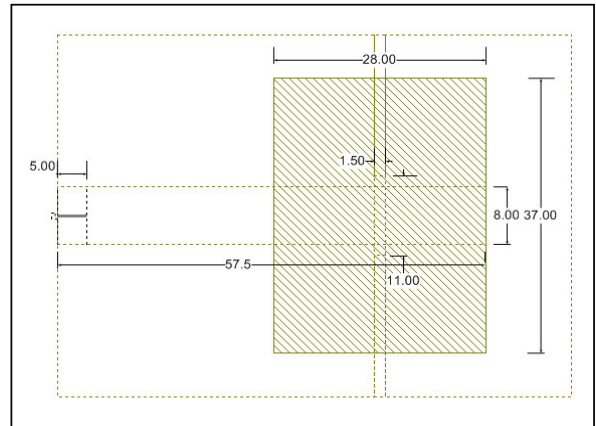

Fig. 3: Dimension of 8mm feed line width aperture coupled microstrip antenna

III RESULT

The designs shown in the previous section have been simulated and fabricated. Then the simulated result and the fabricated result are compared. The simulated and measured return loss result for the passive aperture coupled microstrip antenna is shown in Table 1 while the simulated and measured bandwidth is shown in Table 2.

The simulated passive design resonates at 2.41 GHz while the fabricated resonates at 2.435 GHz. This yields a variation of 0.025 GHz or 1.04% which shows a good approximation for the simulated and fabricated design in its real operation. However, the return loss varied by 6.95 dB or 27%. The return loss graph is shown in Fig. 4. From the data, bandwidth for the rectangular design is 190 MHz in simulation while only 110 MHz in measurement. The summarized result is shown in Table 1 and Table 2.

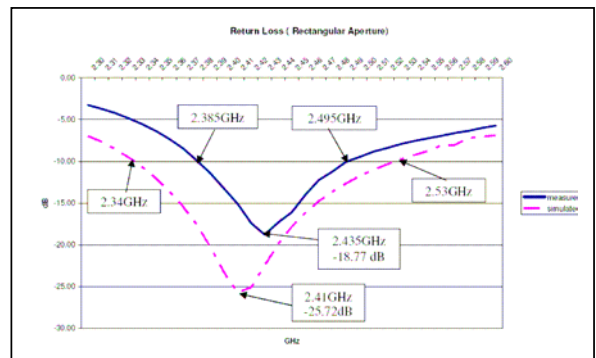
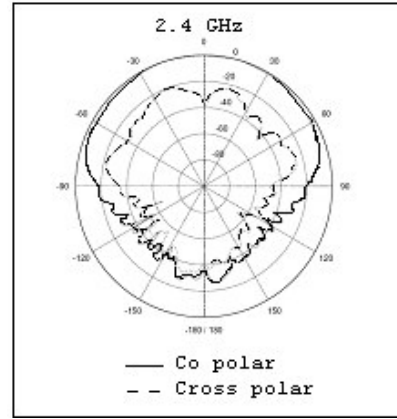

Fig. 4: Comparison of simulated and measured return loss graph for 8mm feed line width

TABLE 1: SIMULATION AND MEASUREMENT OF RETURN LOSS

| Feed Line Width | Model | Return Loss (dB) | Res. Freq (GHz) | Res. Freq Var. (GHz) | Res. Freq Var. (%) |
|-----------------|-------|------------------|-----------------|----------------------|--------------------|
| active | Sim | -21.9 | 2.336 | 0.214 | 9.2 |
| | Meas | -38 | 2.55 | | |
| passive | Sim | -25.72 | 2.41 | 0.025 | 1.04 |
| | Meas | -18.77 | 2.435 | | |



(a) E Plane

TABLE 2: SIMULATION AND MEASUREMENT OF BANDWIDTH

| Feed Line Width | Model | BW Range (GHz) | BW (MHz) | BW (%) | BW Var. (%) |
|-----------------|-------|-----------------|----------|--------|-------------|
| active | Sim | 2.131- >3.1 | 969 | | 42.11 |
| | Meas | 2.24- 2.68 | 440 | | |
| passive | Sim | 2.34- 2.53 | 190 | 7.88 | 42.11 |
| | Meas | 2.385- 2.495 | 110 | 4.52 | |

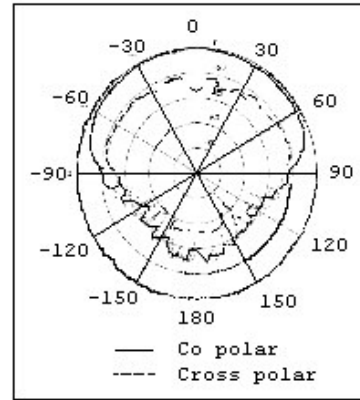

(b) H Plane

Fig. 5: Polar plot radiation pattern for passive antenna

The radiation pattern for passive aperture coupled microstrip antenna give a good HPBW (half power beam width), it has a simulated Half Power Beam Width (HPBW) of 110.28° for H-plane and 81.8° for E-plane while has a measured HPBW of 98° for E-plane and 117° for H-plane. The rectangular aperture coupled feed technique produced a relatively moderate HPBW values and acceptable isolation level (Isolation $< -20\text{dB}$). The measured radiation pattern of the passive aperture coupled microstrip antenna is shown in Fig. 5

The simulated and measured result for active aperture coupled microstrip antenna is summarized in Table 1 and Table 2. The optimal resonant frequency is varied by 0.214 GHz or 9.2%. However, the return loss is suffering a very large variation than the simulated one. Both of the simulated and measured return loss shapes are different. The simulated active antenna gives a very wide bandwidth starting from 2.131 GHz to over 3.1 GHz which comprise more than 0.969 GHz. However, in the real world, the bandwidth is just 0.44 GHz. It is significant drop if compare to the simulated active antenna. The measurement result for active antenna is shown in Fig. 6.

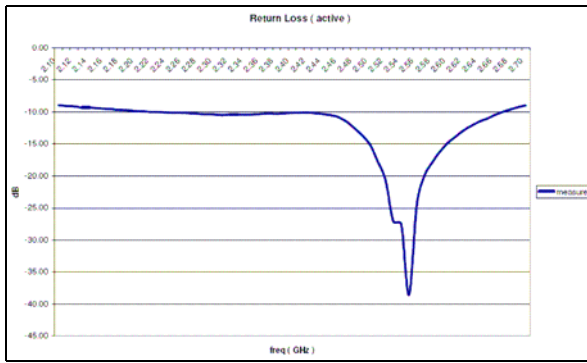
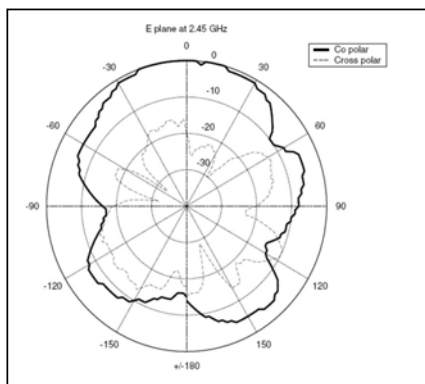
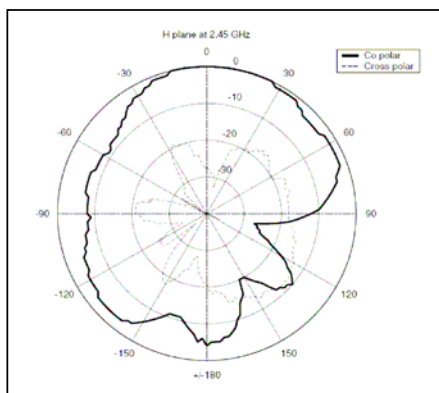

Fig. 6: Measured return loss graph for active ACMA

The radiation pattern of the active antenna design yields simulation results of 100.7° for E-plane and 95.8° for H-plane. The measured result varied from the simulation with 72° for E-plane and 92° for H-plane. The summarized radiation pattern result is shown in Table 3. Figure 7 shows the polar plot of E-plane and H-plane for active aperture coupled microstrip antenna. The HPBW and isolation results are shown in Table 3.



(a) E Plane



(b)H Plane

Fig. 7 : Radiation Pattern for active antenna

TABLE 3: RADIATION PATTERN RESULT

| Feed Line Width | Active | | Passive | |
|----------------------|---------|---------|---------|---------|
| | E-plane | H-plane | E-plane | H-plane |
| HPBW (deg) sim | 100.7 | 95.8 | 110.3 | 110.7 |
| HPBW (deg) meas | 104 | 80 | 117 | 94 |
| Cross Isolation (dB) | 27 | 20 | 35.92 | 15 |
| Gain (dB) | 3 | | 0 | |

IV DISCUSSION

Two comparisons results are made in this paper. Typically, the 3 mm feed line width is designed for 50 ohm line for ordinary microstrip feed antenna and it is applied in the active ACMA. However, the 8 mm feed line width is chosen for the passive ACMA because this width gives the best optimize results after adding the feed line width from 3 mm. In addition, the 3 mm feed width does not make the design works. The 3 mm design resonates at the desired frequency but it does not meet the specification that return loss exceed -10 dB. But, the 8 mm feed width does work with the same dimension for the passive ACMA.

The 3 mm feed line width does work with the active ACMA. One of the reasons of the working is because the active circuit such as the amplifier is added in the antenna. The current which is pumped into the feed is amplified by the amplifier before propagated into the feed line. It makes the coupling power strong enough to couple through the aperture to the patch.

For the variation on return loss, resonant frequency and bandwidth, the main factor is the simulation software constraint. The constraint is the conductor is not able to draw under the substrate. Since the aperture coupled antenna needs the feed to be on the same layer with the ground plane or the aperture, thus one more substrate is defined so that the feed can be drawn on the substrate. On the other hand, the simulation for the active antenna is done by using the schematic only. The air gap existed between the patch with the aperture is a factor as well. In simulation, the design is ideal and no air gap exists between the patch and the ground plane. With the use of adhesive to stick the patch with the ground plane, the variation is affected more

as the adhesive will affect the effective dielectric constant and contribute some height to the gap.

In practical, nothing is perfect and this includes the dielectric material. The dielectric material used in this work, which is the FR-4, has a relative dielectric constant that varies from 4.0 to 4.8 depending on the operating frequency. In simulation, the substrate is assumed to a constant value of dielectric constant. In practice, this definition is unrealistic, as the dielectric constant has certain amount of variation along the length, width and even thickness of the structure.

The usage of adhesive will worsen the situation as this adhesive will contribute dielectric constant as well and contribute to the variation. Other than that, Electromagnetic coupling is one of the important mechanisms to aperture coupled microstrip antenna. But in the simulation, the electromagnetic coupling to the environment is not modeled. While doing return loss measurement, the antenna is not tested in the cleanest environment, thus there will always exists a level of coupling to surrounding objects or even parts of human body.

V. CONCLUSION

A comparison is made between active and passive aperture coupled microstrip antenna. The dimension, return loss graph and polar plot for radiation pattern of the design are shown in this paper. Both designs achieved the best return losses at the desired frequency as well. The active aperture coupled microstrip antenna gives a very outstanding BW and return loss. All the variation issues on the design is discussed, the factors of the variation are pointed out as well.

VI REFERENCES

1. T.A. Denidni, M. Hotton (1999). Design of Aperture-Coupled Microstrip Antenna for Applications in Wireless Communications. *SBMODEEE MIT-S IMOC'99 Proceedings*. IEEE, 654 – 657.
2. D.M Pozar (1996). *A Review of Aperture Coupled Microstrip Antennas: History, Operation, Development, and Applications*. Amherst: University of Massachusetts at Amherst.
3. V. Rathi, G. Kumar, K.P. Ray (1996). Improved Coupling for Aperture Coupled Microstrip Antenna. *IEEE Transaction On Antennas and Propagation, Vol.44*, August: IEEE, 1196 - 1198.
4. Balanis, C.A. (1997). *Antenna Theory: Analysis and Design*. 2nd Ed. New York: John Wiley and Sons.
5. B. Robert., T. Razban, A. Papiernik, 'Compact Amplifier integration in square patch antenna', *Electronic letter*, vol. 28 No. 19, 1992, pp1808-1810
6. M.K.A Rahim, P. Gardner, 'Active Log periodic Antenna' , RF and Microwave Conference 2004, Subang Jaya, Kuala Lumpur Malaysia
7. R.A Sainati (1996). *CAD for Microstrip Antennas for Wireless Application*. Boston: Artech House
8. Soh P.J. (2005). *Microstrip Antenna With Different Feeding Methods*. Universiti Teknologi Malaysia, Master Thesis.