

A Method for Controlling Phase Difference between Propagation Channels for Short-Range MIMO Transmission

#Kazumitsu Sakamoto¹, Ken Hiraga¹, Tomohiro Seki¹,
Tadao Nakagawa¹, and Kazuhiro Uehara¹

¹NTT Network Innovation Laboratories, NTT Corporation
1-1 Hikarinooka, Yokosuka-shi, 239-0847 Japan, sakamoto.kazumitsu@lab.ntt.co.jp

1. Introduction

Higher data rate wireless transmission systems are needed to meet the needs for high-speed wireless transmission of high definition videos and large files. In wireless communications, the multiple-input multiple-output (MIMO) transmission technique [1] has been gathering attention because it can increase the wireless transmission rate without expanding the frequency bandwidth through the use of multiple antennas at the transmitter and receiver. The MIMO technique has found practical consumer use in high-speed wireless LAN systems [2].

In our research, we have focused on the short range MIMO (SR-MIMO) transmission that performs MIMO transmission by utilizing the length differences in the propagation channels between facing transmitting (Tx) and receiving (Rx) array antenna elements in short range wireless communications [3] [4]. As an application of SR-MIMO transmission, we have proposed a wall transmissive wireless repeater (shown in Fig. 1(a)) that is installed on both sides of a wall [5]. The repeater, even in buildings where the laying construction of optical fibers is prohibited, enables high speed data transmission to be performed between rooms and broadband networks to be brought indoors through wireless links. Also, in case of using millimeter wave band, the non-contact high speed data transfer application shown in Fig. 1(b) can be expected because the array antenna becomes small size [6].

As mentioned above, SR-MIMO is characterized by utilizing the length differences in propagation channels to perform signal separation. We have already clarified the existence of optimum element spacing, which maximizes the channel capacity for a given distance between transceivers [3]. For example, when there is a 90-degree phase difference between each propagation channel between transceiver antenna elements, 2×2 SR-MIMO transmission achieves maximum channel capacity. However, in actual usage cases it is likely difficult to perform SR-MIMO transmission over optimum distances using an array antenna designed with a certain element spacing. To address the issue in this paper, we propose a phase difference control technique that adjusts the phase difference between each propagation channel to 90 degrees. This maximizes channel capacity by controlling the transmission (or received) power ratio of sub-array antenna. We also show the proposed method's effectiveness by simulation and experimental evaluation.

The rest of the paper is organized as follows: in section 2, we review SR-MIMO transmission principles and problems; in section 3, we describe our proposed phase difference control technique between each propagation channel by controlling the transmission (or received)

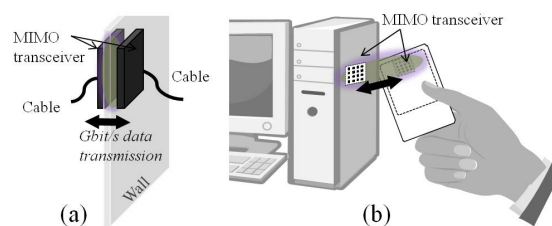

Fig. 1: Application of SR-MIMO transmission technique

power ratio of sub-array antenna; and in section 4, we show the effectiveness of the proposed method.

2. Short-Range MIMO

Figure 2 shows a 2×2 SR-MIMO transmission model. General MIMO transmission can transmit multiple signal streams by utilizing the multipath-rich environment in which low spatial correlation can be achieved between multiple antenna elements. On the other hand, SR-MIMO utilizes the length differences among each propagation channel between facing transmitting (Tx) and receiving (Rx) array antenna elements in order to achieve full-rank MIMO transmission. In SR-MIMO, when Tx and Rx array antennas are very close relative to the antenna's element spacing, low spatial correlation can be achieved between adjacent elements because the signals that reach those elements have different phases and amplitudes depending on the path length differences [3][4].

Figure 3 shows the relationship between 2×2 SR-MIMO channel capacity and antenna element spacing for this model. The relationship between phase difference and antenna element spacing is also shown. Frequency is 4.85 GHz and transmission distance D is 120 mm. As the figure shows, in SR-MIMO transmission the channel capacity is maximized when there is optimum element spacing, in which there is a 90-degree phase difference between each propagation channel [3] [7]. That is, a 2×2 channel matrix with optimum element spacing is approximated by Eq. (1).

$$\mathbf{H} = \begin{bmatrix} h_{11} & h_{12} \\ h_{21} & h_{22} \end{bmatrix} \approx h_{11} \begin{bmatrix} 1 & -aj \\ -aj & 1 \end{bmatrix} \quad \left(a = \left| \frac{h_{21}}{h_{11}} \right| \right) \quad (1)$$

Here, $h_{i,j}$ (i and j : positive integers less than or equal to 2) denotes the propagation channel component from the j -th Tx antenna to the i -th Rx antenna. Moreover, as shown in Fig. 3, with optimum element spacing the channel capacity achieved by using zero forcing (ZF) is almost the same as that achieved by using eigenmode beamforming (EM-BF).

However, in applications involving the use of a wireless repeater or a non-contact high speed data transfer system (see Fig. 1), it is difficult to perform SR-MIMO transmission over optimum distances using an array antenna designed with a certain element spacing. If displacement from optimum transmission distance occurs, SR-MIMO performance degrades due to displacement from a 90-degree phase difference, which is the optimum condition for propagation channels.

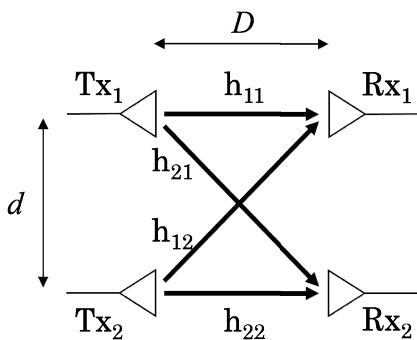

Fig. 2: 2×2 SR-MIMO transmission model

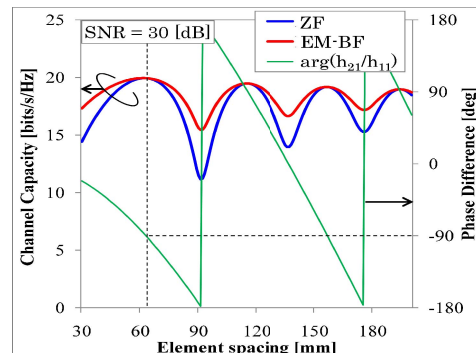

Fig. 3: Channel capacity and phase difference versus antenna element spacing

3. Phase Difference Control Technique

In this section, we describe our proposed method of compensating for the displacement from a 90-degree phase difference. In the method, as shown in Fig. 4, multiple antenna elements are used as a sub-array antenna and the phase difference between each propagation channel is adjusted to 90 degrees, which enables channel capacity to be maximized by controlling the sub-array antenna's transmission (or received) power ratio. Two sub-array antennas in each Tx and Rx array antenna are used to perform 2×2 SR-MIMO transmission. Each sub-array antenna consists of two antenna elements. The ratio of signal power transmitted by antenna element #1 to the signal power

supplied to sub-array antenna 1 is represented by α , where $0 \leq \alpha \leq 1$. The ratio of transmission signal power P_1 of antenna element #1 to transmission signal power P_2 of antenna element #2, i.e., the power ratio, is represented as $P_1 : P_2 = \alpha : 1 - \alpha$.

When α is 1 (see Fig. 4(a)), the signal transmitted by sub-array antenna 1 is radiated to the propagation channel on the basis of antenna element #1's directivity pattern. When α is 0 (see Fig. 4(b)), the signal is radiated on the basis of antenna element #2's directivity pattern. When α is 0.5, the directivity pattern's peak points forward on the perpendicular bisector of antenna elements #1 and #2 because the signal is radiated by antenna elements #1 and #2 with the same power. The sub-array antenna's radiation point is changed to a pseudo-point by changing the power ratio of each sub-array antenna element. Thus, as shown in Fig. 4, it is possible to adjust the phase difference $\theta_H = \arg(h_{21}/h_{11})$ between channel h_{11} from sub-array antenna 1 to sub-array antenna 3 and channel h_{21} from sub-array antenna 1 to sub-array antenna 4. In the receiver, the received point is also changed to a pseudo-point by changing the combining ratio of each signal received by the antenna element. In this way, the phase difference between each propagation channel can be adjusted.

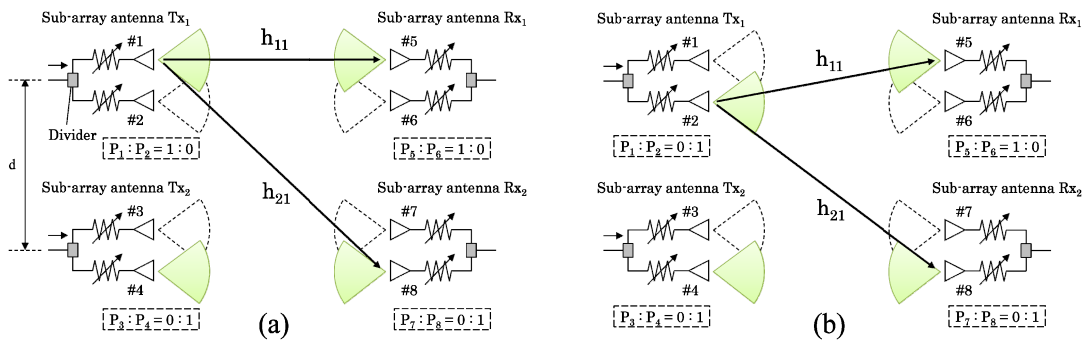

Fig. 4: Principle of phase difference control with proposed method

4. Performance Evaluation

Figure 5 shows an evaluation model for 2×2 SR-MIMO transmission. Frequency is 4.85 GHz, transmission distance D is 300 mm, sub-array antenna spacing d is 88.0 mm, and element spacing of the sub-array antenna's two antenna elements is half wavelength. Figure 6 shows the details of the sub-array antennas. The antenna elements are microstrip antennas $19.5 \text{ mm} \times 19.5 \text{ mm}$ in size and are formed on finite-size dielectric substrates whose thickness is 1.56 mm, dielectric constant is 2.17, and loss tangent is 0.0005. Each element has one feed point located 3.60 mm from the antenna center. The elements are designed to have matched impedance at 4.85 GHz. The power ratio of each Rx sub-array antenna elements is set to 0.5 : 0.5 and only the power ratio of Tx sub-array antenna elements is changed using variable attenuators. In the above described configuration, we analyzed a 2×2 MIMO channel using electromagnetic simulation by the Method of Moment. The configuration was kept the same during measurement as was simulated.

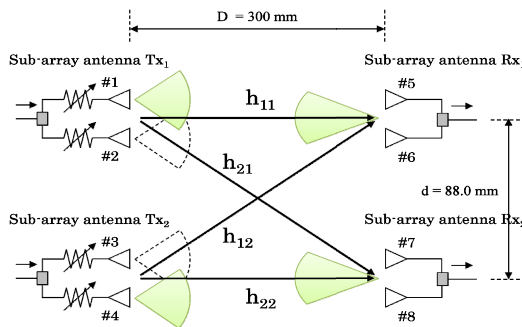

Fig. 5: Evaluation model

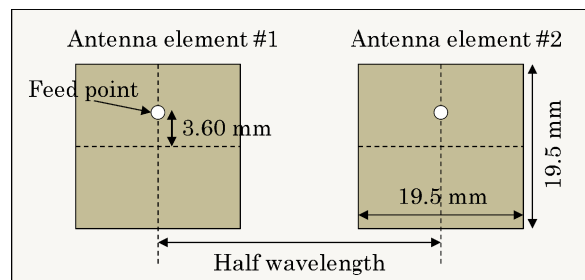

Fig. 6: Sub-array antenna configuration

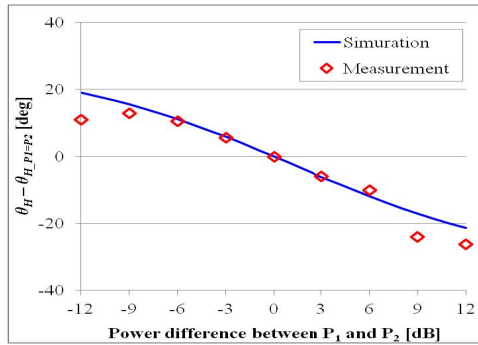

Fig. 7: Variable range of phase difference

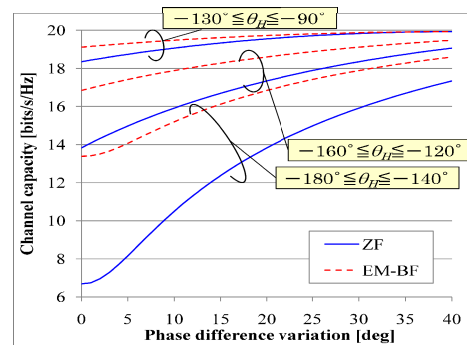

Fig. 8: Channel capacity improvement

Figure 7 shows the variable range of phase difference $\theta_H = \arg(h_{21}/h_{11})$ between each propagation channel obtained with the proposed method in both simulation and measurement. The horizontal axis represents transmission power difference between P_1 and P_2 . From the 0 mark to the right is an increase in P_1 , and to the left is an increase in P_2 . The vertical axis represents the difference between θ_H and $\theta_{H, P_1=P_2}$, where $\theta_{H, P_1=P_2}$ is the phase difference in $P_1 = P_2$. The method was able to adjust the phase difference within a range of about 40 degrees. Figure 8 shows channel capacity improvement when the phase difference is adjusted within a range of about 40 degrees, (e.g. $-130^\circ \leq \theta_H \leq -90^\circ$, $-160^\circ \leq \theta_H \leq -120^\circ$, and $-180^\circ \leq \theta_H \leq -140^\circ$). The 0 mark of the horizontal axis represents $\theta_H = -130^\circ$, -160° , -180° , respectively. The method can improve channel capacity by from 1.5 to 10 bits/s/Hz.

5. Conclusion

We proposed a method in which the phase difference between each propagation channel is adjusted by controlling the transmission (or received) power ratio of each sub-array antenna element. In this way the method compensates for the displacement from optimum phase difference in SR-MIMO transmission. In simulation and experimental evaluations, we clarified that the proposed method can adjust the phase difference within a range of about 40 degrees in 2×2 SR-MIMO transmission when the transmission power ratio is only controlled. We also clarified that the method can improve channel capacity by from 1.5 to 10 bits/s/Hz. Furthermore, it is expected that the proposed method can adjust the phase difference within a range of about 80 degrees when the transmission and received power ratio are controlled.

References

- [1] G. J. Foschini and M. J. Gans, "On limits of wireless communications in a fading environment when using multiple antennas," *Wireless Personal Commun.*, vol. 6, no. 3, pp. 311-335, Mar. 1998.
- [2] IEEE STD 802.11n.
- [3] N. Honma, K. Nishimori, T. Seki, and M. Mizoguchi, "Short Range MIMO Communication," in *The 3rd European Conference on Antennas and Propagation (EuCAP 2009)*, Mar. 2009.
- [4] K. Nishimori, T. Seki, N. Honma, and K. Hiraga, "On the Transmission Method for Short Range MIMO Communication," *IEEE Trans. on VT*, vol. 60, no. 3, pp. pp.1247-1251, Mar. 2011.
- [5] T. Seki, K. Nishimori, K. Hiraga, and K. Nishikawa, "High Speed Parallel Data Transmission Technology for Short Range Wireless Relay System," *IEICE Tech. Rep., AP2009-55*, pp. 65-70, July 2009.
- [6] K. Hiraga, T. Seki, K. Nishimori, K. Nishikawa, I. Toyoda, and K. Uehara, "Analyses of Antenna Displacement in Short-Range MIMO Transmission over Millimeter-Wave," *IEICE Trans. on Commun.*, vol. E94-B, no. 10, pp. 2891-2895, Oct. 2011.
- [7] P. F. Driessen, and G. J. Foschin, "On the Capacity Formula for Multiple Input-Multiple Output Wireless Channels: A Geometric Interpretation," *IEEE Trans. on Commun.*, vol.47, no.2, pp.173-176, Feb. 1999.