

A FLAT DIVERSITY ANTENNA BY DISK LOADED MONOPOLE AND THREE NOTCHES

Seiji HOSONO[†], Hiroyuki ARAI,[†] Naohisa GOTO^{††}

[†]*Division of Electrical and Computer Engineering, Faculty of Engineering, Yokohama National University, Yokohama-city, 240 Japan.*

^{††}*Department of Electric and Electronic Engineering, Faculty of Engineering, Tokyo Institute of Technology, Tokyo, 152 Japan.*

SUMMARY— A flat diversity antenna, consisting of a disk loaded monopole antenna (DLM) and three notch antennas composed in the same disk, is proposed as a vehicular antenna to reduce a fading effect of urban mobile telephone. Three notches are used for a turnstyle antenna to obtain small correlation coefficient for the disk loaded monopole antenna. The propagation measurement verifies the diversity effect of a new flat diversity antenna.

1. Introduction

Techniques to reduce multipath fadings in a land mobile communication system are space diversity, polarization diversity, antenna pattern diversity, and energy density reception for antenna diversity. According to a random propagation model, the diversity effect depends on a correlation coefficient between two antennas. Small correlation coefficient is obtained by different amplitude radiation pattern or different phase pattern. A flat energy density antenna consists of a disk loaded monopole antenna and four notch antennas designed as a crossed slot antenna composed in the disk [1][2]. While the electric field is received by the disk loaded monopole antenna, the magnetic field by the notch array; as a result, the energy density reception is obtained. The energy density reception is obtained by this antenna, however, it is also explained by two antennas with small correlation coefficient based on different phase radiation pattern.

This paper presents a new flat diversity antenna, reducing the electrical volume of the antenna by altering four notch array to three, and measurement results of its input characteristics, radiation pattern and propagation measurements. In addition, the radiation pattern in a horizontal plane of a notch antenna is explained using a model of a magnetic current.

2. Flat Diversity Antenna

The turnstyle radiation pattern of four notches excited with phase difference of 90° is equivalent to that of three notches excited with phase difference of 120° . This antenna and its input impedance characteristics (return loss, isolation) is shown in Figs. 1 and 2, respectively. This excitation is given by a power divider and delay lines. The horizontal phase radiation pattern is constant for the disk loaded monopole. On the other hand, it varies from 0 to 2π for the turnstyle notch antenna. As a result, this combination is expected to give a small correlation coefficient as two diversity branches.

Table 1 shows the frequency band width, the isolation between antennas, and electrical volume for the flat diversity antenna of four and three notches. Three notch array reduces the physical volume of the flat diversity antenna a factor of 59.1%, and also reduces normalized antenna volume 27%. (The antenna volume is normalized by frequency band width of the disk loaded monopole in Table 1). The fractional frequency

bandwidths with a return loss of less than -10dB are 5.6% for the disk loaded monopole, and 3.1% for each notch antenna. The isolation between the ring patch and each notch is less than -9.5dB, and that between notches is less than -7.3dB (Tab. 1). The mutual coupling between notches are increased by 2dB, compared with four notch array.

The mutual couplings disturb the radiation pattern of a notch antenna in Fig. 3. The radiation from the notch antenna is assumed to be a figure of eight pattern in the horizontal plane, assuming a magnetic line current on the notch. However one notch antenna is excited, other two notches terminated to dummy loads are excited by the mutual coupling between notches. In other words, we can assume a magnetic currents on these two notches, which causes an elliptical radiation pattern.

When we assume a phase difference of $\pm 120^\circ$ respectively between the adjacent magnetic currents (confirmed by experiment), radiation pattern $E(\theta)$ of notch antenna in a horizontal plane is given by

$$E(\theta) = A(\theta)e^{-j\phi(\theta)} + MA(\theta + \frac{2}{3}\pi)e^{-j\phi(\theta - \frac{2}{3}\pi)} + MA(\theta + \frac{4}{3}\pi)e^{-j\phi(\theta + \frac{2}{3}\pi)} \quad (1)$$

where $A(\theta)$ is the horizontal radiation pattern of the notch antenna, and M is amplitude coefficient between notches. The calculated result, in Fig. 3, agrees well with measurement.

The mutual coupling is calculated by magnetic current filaments shown in Fig. 4. The amplitude of phase of mutual coupling are shown in Fig. 5(a)(b). The mutual coupling is -7.3dB for $d=2\text{cm}$ to explain the isolation characteristics, however, the phase difference of $d=2\text{cm}$, -154° , is not agree with eq.(1). It is necessary to explain the notch array performance by an analysis model of magnetic line or sheet current.

3. Propagation Measurements

We made propagation measurements at 900MHz band to verify the diversity effect of the flat diversity antenna. In the measurement, two antenna outputs were inputted to a spectrum analyzer, and data were recorded in a digital form at each one-tenth wavelength in free space interval.

Figures 6 shows the cumulative probability of the signal strength referred to the median value of the main antenna. The main antenna is the disk loaded monopole, and the sub antenna is the turnstyle notch antenna. The curve of the selection diversity shows that this flat antenna provides as efficient two diversity branches, where the voltage correlation coefficient is 0.13 for the flat antenna.

4. Conclusion

This paper presented the flat diversity antenna for mobile telephone consisted of the disk loaded monopole antenna and turnstyle notch antenna. A prototype of the flat antenna has been built and tested at 900MHz band, and its measured results of the input impedance characteristics and the radiation patterns are presented. The radiation pattern of notch antenna was explained using a model of magnetic current. The voltage correlation coefficient is 0.13 between the ring patch and the turnstyle notch antenna. We also verified the diversity effect of the flat antenna by the field measurement. The flat diversity antenna is shown to be useful for the diversity antenna of mobile telephone systems.

References

- [1] H. Arai, H. Iwashita, M. Toki, and N. Goto, "A flat energy density antenna system for mobile telephone", *IEEE Veh. Techno.*, vol. 40, pp.483-486, May 1991
- [2] H. Arai, H. Iwashita, and N. Goto, "Vehicular diversity flat antenna at 900 MHz", *IEICE Trans.*, vol.E 74, no.10, pp.3222-3226, Oct. 1991

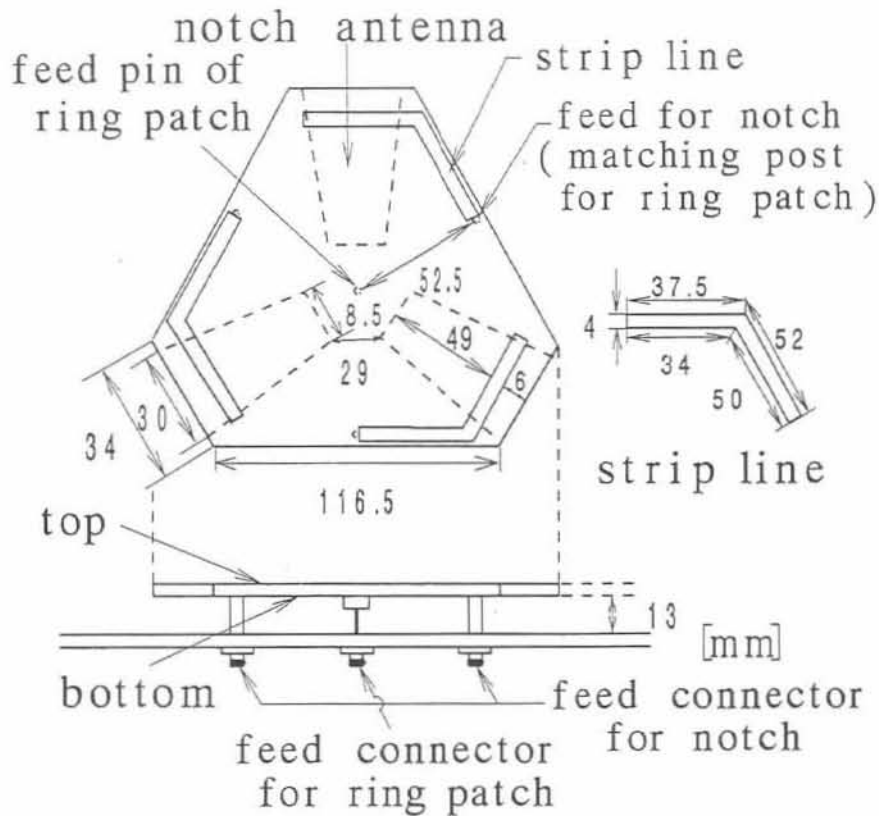

Fig. 1 Flat diversity antenna

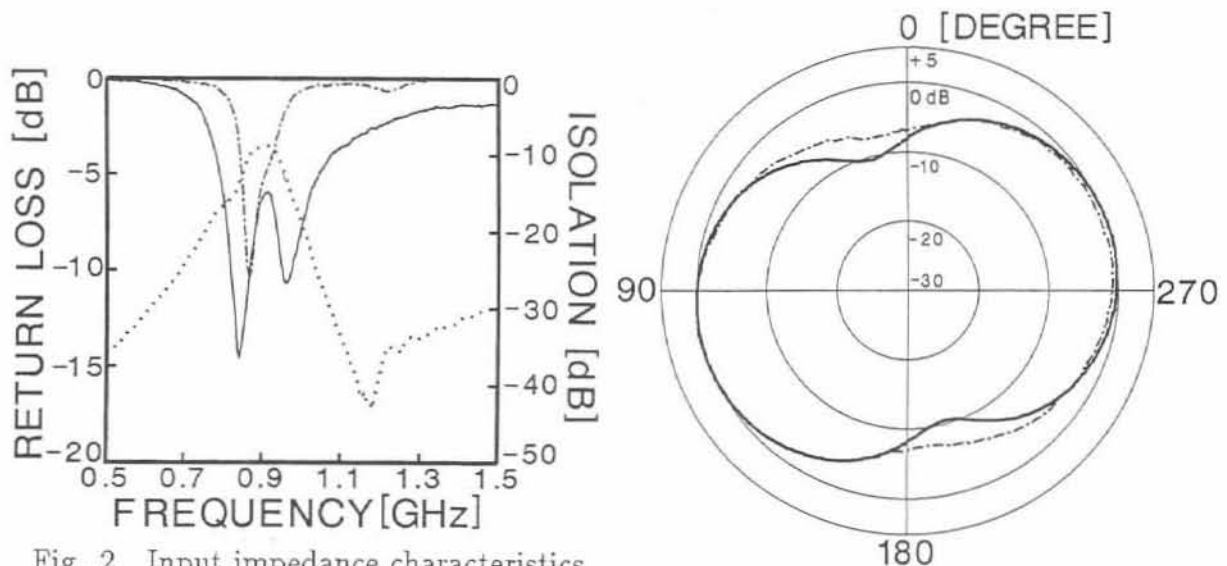

Fig. 2 Input impedance characteristics

- Return loss of DLM
- - - Return loss of notch
- · · Isolation

Fig. 3 The horizontal radiation pattern of a notch antenna

- Measured
- - - Calculated

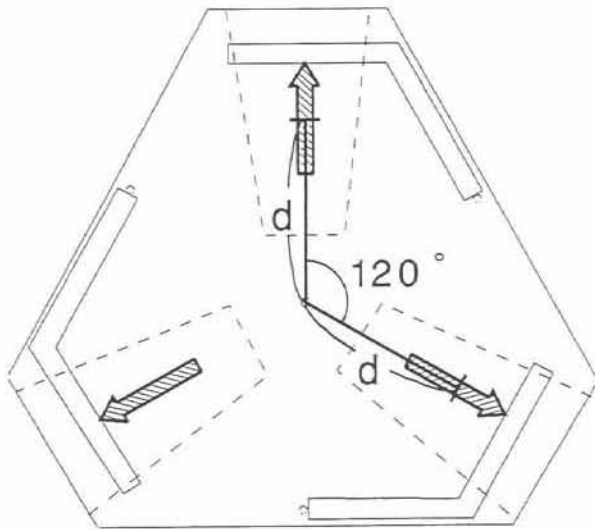
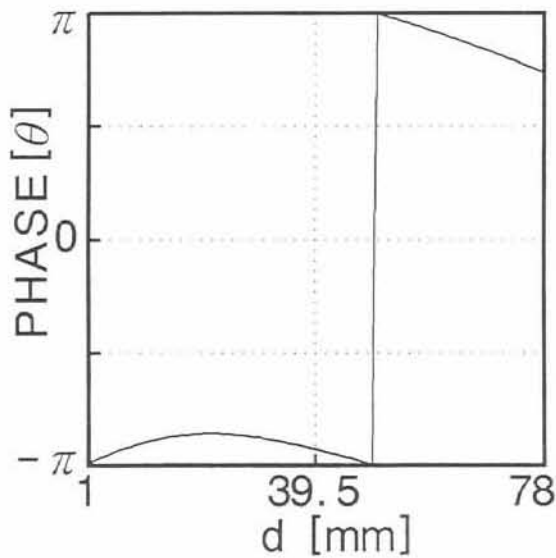

Fig. 4 Mode of magnetic current filaments

Table1 Frequency bandwidth, isolation, antenna volume of 4/3 notches array

number of notch	4	3
bandwidth of DLM [%]	10.0	5.6
bandwidth of notch [%]	4.5	3.1
isolation between DLM and notch [dB]	-10.6	-9.5
isolation between notches [dB]	-9.4	-7.3
antenna volume [cm ³]	4.77×10^2	1.95×10^2
normalized volume [cm ³ /%]	4.77×10^3	3.47×10^3



(a) Phase vs. distance

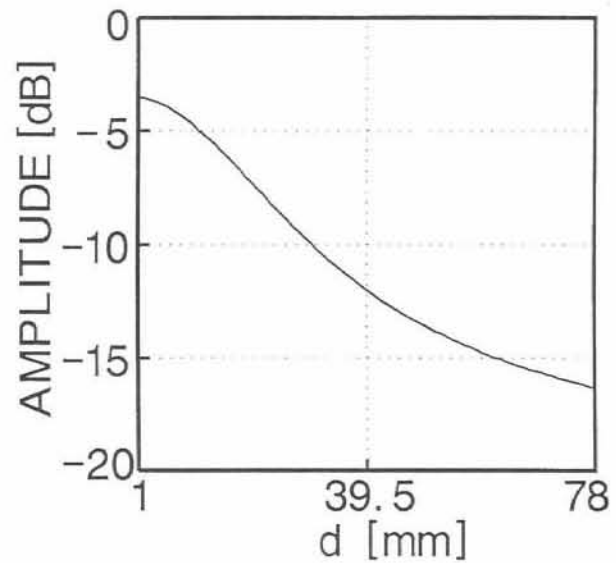

(b) Amplitude vs. distance

Fig. 5 Mutual coupling between magnetic current filaments

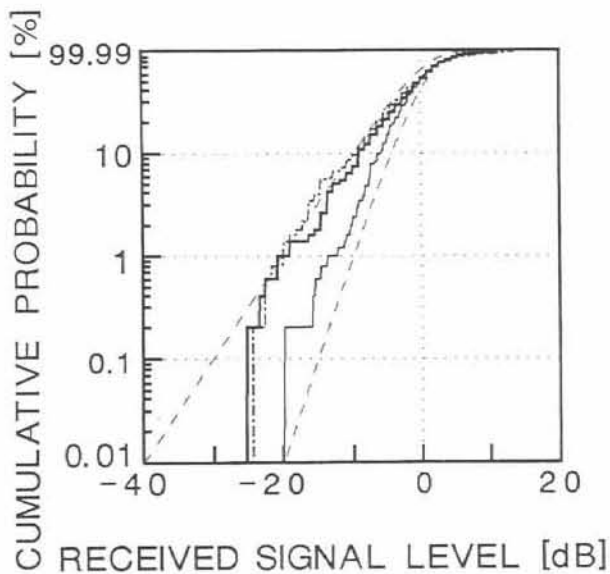

Fig. 6 Cumulative Probability

— Main - - - Sub
 . . . Diversity
 - . - - Layleigh diagram