

A Q-Band Dual-Mode Cavity-Backed Wideband Patch Antenna with Independently Controllable Resonances

Tao Zhang, Yan Zhang, *Member, IEEE*, Shunhua Yu, Wei Hong, *Fellow, IEEE*, and Ke Wu, *Fellow, IEEE*
State Key Laboratory of Millimeter Waves, School of Information Science and Engineering,
Southeast University, Nanjing, 210096, P. R. China
taozhang@emfield.org, weihong@seu.edu.cn

Abstract—In this paper, a dual-mode cavity-backed patch antenna and a 2x2 array is proposed for Q-band wireless applications. In addition to the original TM01 mode of patch antenna, an independently controllable resonance is introduced by loading the antenna with an inductive via and an annular slot. The bandwidth (return loss < -10 dB) of the antenna element is thus expanded to 12.4% while the bandwidth of the 2x2 array is 12.7%, with a peak gain of 6.57 dBi and 10.6 dBi, respectively. The 2-dB gain bandwidth of the array is wider than 13.95%. Besides, in order to provide a deep understanding of the antenna, a fully physically based circuit model is presented. The circuit simulation and full wave simulation agree well with the measurements.

Key words— dual-mode, cavity backed, patch antenna, circuit model

I. INTRODUCTION

With a rapid development of millimeter-wave wireless communications, many researches are focusing on antennas operating in millimeter-wave bands with a sufficient bandwidth.

Conventional cavity backed patch antennas enjoy the advantages of easy fabrication compatibility with integrated circuits systems, low weight, low mutual coupling when forming an array, and then it is reasonable to adopt this kind of antennas for millimeter-wave applications. However, patch antennas only have one resonance, which implies narrow bandwidth. In order to overcome such shortcoming, numerous efforts have been dedicated to expanding the bandwidth of patch antennas, including: 1) using thick substrate with low permittivity, 2) employing matching stubs on the feeding lines, and in millimeter-wave applications, 3) introduce more resonances. However, 1) and 2) are limited by some disadvantages such as the easy excitation of surface wave on thick substrates, the tedious size introduced by the matching stubs. As for 3), parasitic patches [1], L-shaped probes [2], slots on patches [3], are adopted. Many of these techniques may have their own application contexts and may have some drawbacks: the tedious size introduced, the structural complexities, and high cross polarization, etc.

In this paper, a method to expand the bandwidth of patch antennas is presented for Q-band wireless communications, such as the point-to-point system (40.5–43.5GHz) for backhaul application and IEEE 802.11aj etc. By loading an inductive

via and a capacitive annular slot, an additional resonance is introduced. The additional resonance, in combination with the original one of the patch mode, expands the -10dB-returnLoss bandwidth of the antenna element to 12.4%, ranging from 38.85 GHz to 43.98 GHz. Moreover, a physically based circuit model is presented to illustrate the mechanism of the antenna.

II. THE ANTENNA ELEMENT

A. Antenna Configuration

The geometry of the antenna element is shown in Fig. 1. The feeding CPW is etched on the ground of the antenna, and at the end of the CPW, a pad is introduced on which a feeding via is used to connect the patch and the pad. The feeding via also serves as an inductor. Under the via is a pad which serves as the positive plate of the introduced capacity while the negative plate is the ground of the antenna. The antenna is designed on a substrate of Rogers 5880 with a thickness of 0.508mm.

B. Circuit Model and Antenna Mechanism

In Fig. 2, it is shown that the antenna has two resonances: one is at $f_1=40.45\text{GHz}$, another is at $f_2=43\text{GHz}$. As is shown in Fig. 3(a),(b), at f_1 , the field resonates as the typical TM01 mode of patch antennas while the field resonates around the inductive feeding via and the annular slot on the ground at f_2 , which verifies that a new mode is introduced by the above two elements.

In order to deeply explain this phenomenon, a detailed circuit model is presented in Fig. 4(a), with its simplified counterparts in Fig. 4(b). The TM01 model is modeled by Lh , Lpa , Cpa , and Ri . The inductive feeding via is modeled by $Lprb$ while the annular slot is modeled by $Cgap$. A mutual inductor is adopted to model the distorting effects of the via on the TM01 model as shown in Fig. 3(c). $Cp2p$ illustrates the capacity between the pad and the patch while $Cgap$ represents the capacity between the upper metal and the patch. $Lcav$ is used to model the cavity, which is negligible since the cavity is formed by many inductive vias in parallel, making $Lcav$ rather small. Moreover, Lh , used to model the effects of higher modes, is also neglected since only the dominant mode is considered in our design. The capacity denoted by $Cp2p$ is ignored for the illustrative circuit model. Finally, $Cgap$ is

absorbed into Cpa , resulting in $Cpa2$ in Fig. 4(b). Since many complex effects are neglected, the circuit model is quite an illustrative one, used only to qualitatively explain the antenna mechanism. As shown in Fig. 2, the simulation between the circuit and HFSS agree well, which demonstrates the validity of the circuit model.

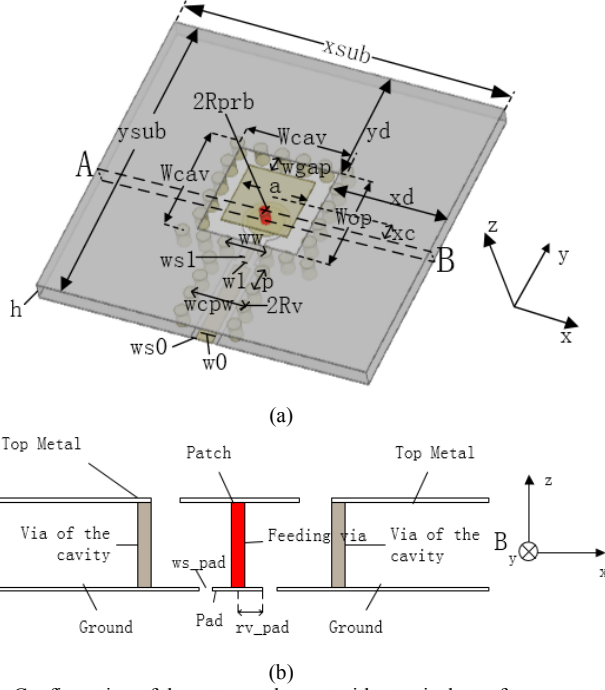

Fig. 1. Configuration of the antenna element with a typical set of parameters: $x_{sub}=6.7$, $y_{sub}=10$, $x_d=0.5$, $y_d=3.5$, $x_c=0.3$, $W_{cav}=3.3$, $W_{op}=3$, $w_w=1.2$, $w_{cpw}=1.6$, $w_0=0.5$, $w_1=0.15$, $w_{s0}=0.15$, $w_{s1}=0.2$, $w_{s_pad}=0.15$, $w_{gap}=0.5$, $r_{v_pad}=0.53$, $r_{prb}=0.15$, $a=2$, $R_v=0.2$, $p=0.65$, all parameters are in "mm". (a) overall view, (b) sectional view.

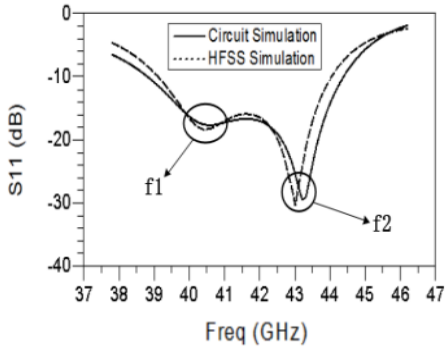

Fig. 2. Simulated return loss (in dB) by HFSS and circuit model.

Fig. 5 presents the behaviors of the two resonances as parameters change. In Fig. 5(a), as "a" (the length of the square patch) increases by even steps, f_1 decreases with equal intervals with a merely slight influence on f_2 , as is expected for TM₀₁ mode of patch antennas. In Fig. 5(b), as r_{v_pad} increases, f_2 shifts down. This attributes to the increase of C_{gap} in Fig. 4(b) based on formula (1). Similar rules and explanations stand for "ws_{pad}", which is not provided here. In Fig. 5(c), as the radius of the feeding via goes higher, f_2

increases since L_{prb} decreases. As shown in Fig. 5(d), x_c influences the depth of the S11 curve, that is, the matching of the antenna, while maintaining the resonant frequencies. We have to inform that the analysis by (2) is quiet a rough one, since it is based on single RLC series or parallel circuit. In fact, a more rigorous one, done by simulating the circuit when tuning the relative element in Fig. 4(b), agrees with the above explanation, which is not provided here.

$$f_0 = \frac{1}{2\pi\sqrt{LC}} \quad (1)$$

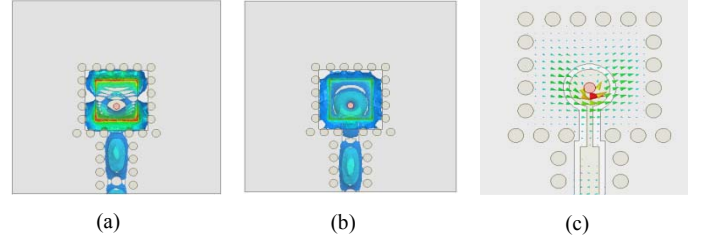

Fig. 3. Field distribution in the cavity. (a) E-Field at f_1 , (b) E-Field at f_2 , and (c) H-field distorted by the feeding via.

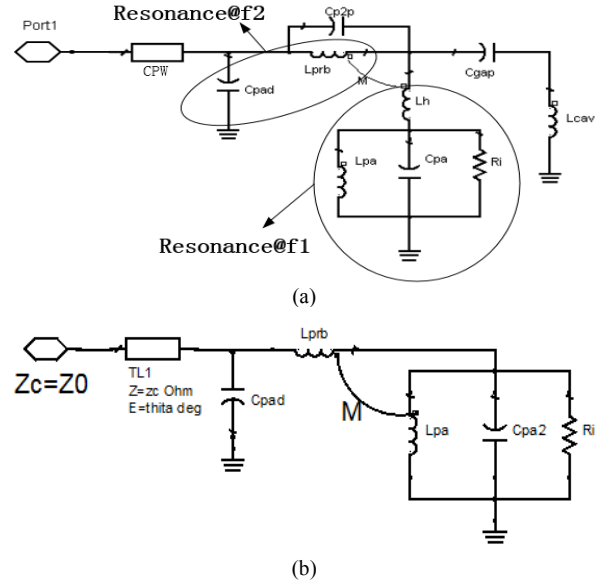

Fig. 4. Circuit model for the proposed antenna. (a) Detailed circuit model, (b) Simplified circuit model: $Z_0=75\Omega$, $C_{pad}=0.166\text{pF}$, $L_{prb}=0.117\text{nH}$, $L_{pa}=0.017\text{nH}$, $M=0.00627\text{nH}$, $C_{pa2}=0.863\text{pF}$, $R_i=30\Omega$, $z_c=234\Omega$, $\theta_{ita}=194\text{deg}$.

C. Design Procedure

First, the size of the square patch is determined based on center frequency of a traditional patch antenna. Second, the size of the annular ring is adjusted until a new resonance appears at a proper frequency. Finally, the position of the feeding point, denoted by x_c , is adjusted to achieve a good matching.

Determination of other parameters: w_{gap} is selected the same as the thickness of the substrate, which in turn determines the size of the cavity; the feeding via is set to be as thin as the fabrication standards permit (this has two benefits: the feeding point would be smaller so that it is closer to a

lumped excitation; the inductor introduced is larger so that the annular slot could be smaller based on (2), which will help reduce backward radiation.); the width of the annular slot should be as small as possible because this indicates larger capacity, which in turn will help reduce the annular slot.

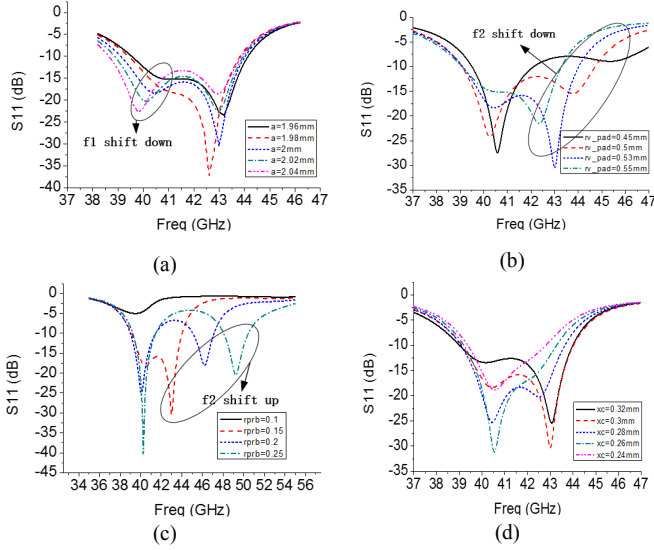

Fig. 5. Parameter study of the proposed antenna by HFSS.

D. Antenna Performance

In order to test the performance of the antenna, the 75Ohm feeding line is matched to 50Ohm by a quarter-wave CPW. The structure is shown in Fig. 6. The simulated and measured performance is shown in Fig.7. The simulated bandwidth is 14.2%, ranging from 39.3 GHz to 45.3 GHz. The measured bandwidth (return loss < -10 dB) of the antenna element is 12.4%, ranging from 38.85 GHz to 43.98 GHz, with a gain of 6.57dBi at f_1 and 6.2dBi at f_2 . The measured return loss shifts lower by 2%, causing a bandwidth sacrifice of 1.8%. This mainly attributes to fabrication errors and improper estimation of dielectric constant at Q bands.

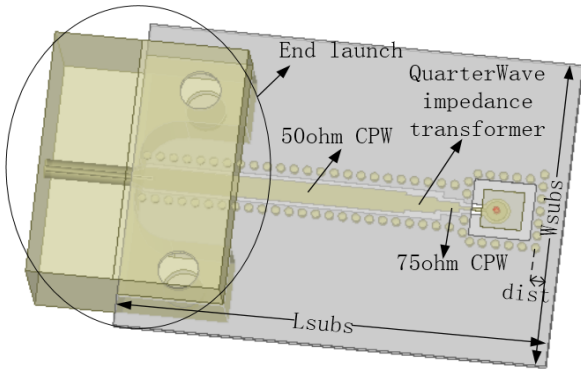
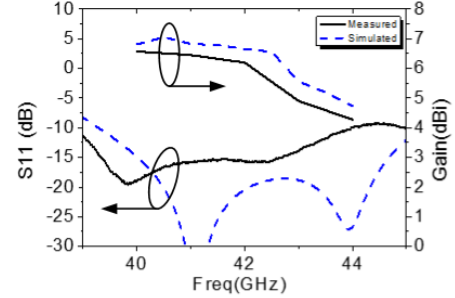

Fig.6. Antenna structure for measurement.

$L_{sub}=21\text{mm}$, $W_{sub}=16\text{mm}$, $r_{v_pad}=0.5\text{mm}$, $dist=1.5\text{mm}$.

In Fig. 7(c), the side lobe at 90° is irregularly high. This is due to the influence of the metal end launch which serves as a reflector. As a result, the boresight gain suffers from a drop at higher frequencies as shown in Fig. 7(a). In fact, the simulated

gain without the end launch shown in Fig. 1(a) is 7.27dBi at f_1 and 6.52dBi at f_2 , which verifies that the gain drop is mostly caused by the end launch rather than the annular slot on the ground. In applications, this effect could be avoided by etching the patch on the ground of the circuit boards when integrated with circuit systems.



(a) Return loss and boresight Gain

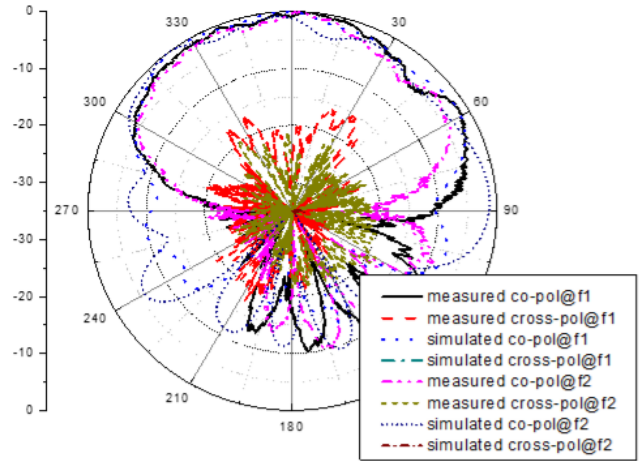

(b) E-Plane radiation pattern

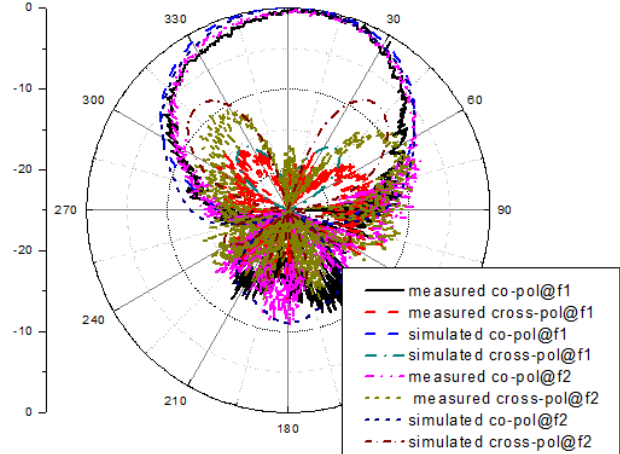

(d) H-Plane radiation pattern

Fig.7 Performance of the antenna element.

III. ANTENNA ARRAY

In addition to the antenna element, we also designed a 2x2 array using parallel-feeding technique. The feeding network consists of a 180° self-compensating phase shifter [6], a divider and a SIW to CPW transition [7]. The overall structure is shown in Fig.8 (the end launch is not shown) with its performance shown in Fig.9. The size of the square patch is optimized to 1.92mm and rv pad to 0.48mm, xc to 0.33mm. The simulated impedance bandwidth and the 2-dBi gain bandwidth are 13.95%, both of which ranging from 40 GHz to 46 GHz. The measured return loss shifts higher by 2%, ranging from 41 GHz to 46.7 GHz, with a sacrificed bandwidth of 0.3 GHz. The discrepancy between the simulated and measured results in Fig.9 (a) mainly attributes to fabrication errors and improper estimation of dielectric constant of the substrate at Q-Bands. The overlapping bandwidth is 11.4%, from 41GHz to 46 GHz.

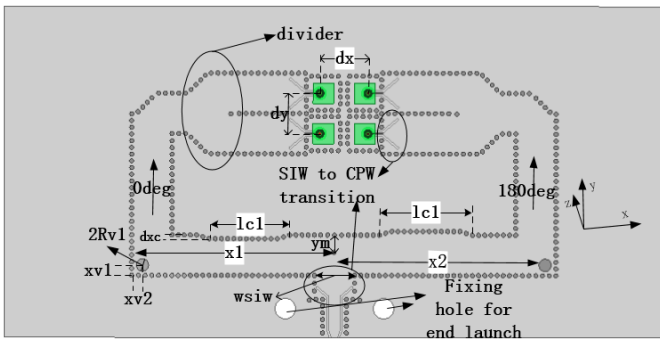
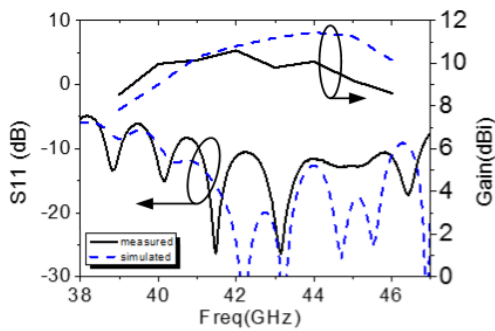
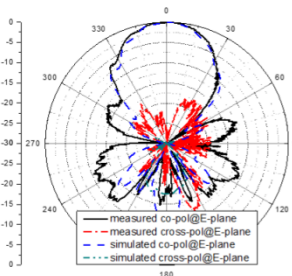

Fig.8. Structure of the 2x2 array. $xv1=1.05\text{mm}$, $xv2=1\text{mm}$, $dxc=0.36\text{mm}$, $Rv1=9\text{mm}$, $lcl=l_{c2}=9\text{mm}$, $dx=4\text{mm}$, $dy=3.9\text{mm}$, $x1=19.57\text{mm}$, $x2=21.53\text{mm}$, $wsiw=3.9\text{mm}$. The size of the substrate is 64mmx32mm.



(a) Gain and return Loss



(b) E-plane pattern at 43GHz

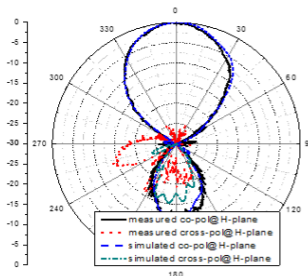

(c) H-plane pattern at 43GHz

Fig.9. Performance of the 2x2array.

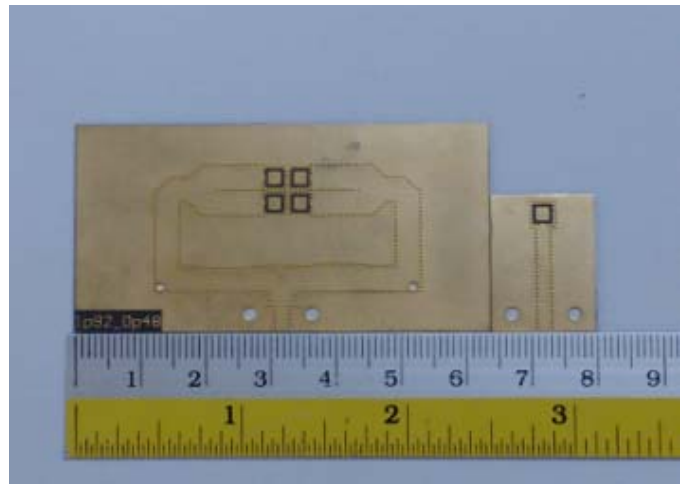

Fig.10. Photograph of the antenna element and array.

IV. CONCLUSION

In this paper, a dual-mode cavity-backed patch antenna with independently controllable resonances is proposed and studied in detail. Moreover, a 2x2 array based on this antenna is presented. The photograph of the antenna element and array are presented in Fig. 10.

ACKNOWLEDGMENT

This work was supported in part by National 973 project 2010CB327400 and in part by NSF of Jiangsu province under Grant SBK201241785.

REFERENCES

- [1] Sang-Hyuk Wi, Yong-Shik Lee and Jong-Gwan Yook, "Wideband Microstrip Patch Antenna With U-Shaped Parasitic Elements", *IEEE Trans. Antennas Propagat.*, vol.55, Issue 4, April 2007.
- [2] Mak, C.L, Luk,K.M, Lee,K.F "Experimental study of a microstrip patch antenna with an L-shaped probe", *IEEE Trans. Antennas Propagat.*, vol.48, Issue 5, May 2000.
- [3] K. F. Lee, K. M. Luk, K. F. Tong, S. M. Shum, T. Huynh, and R. Q. Lee, "Experimental and simulation studies of coaxially fed U-slot rectangular patch antenna," *Inst. Elect. Eng. Proc. Microwave Antennas Propagat.*, vol. 144, 1997.
- [4] Yu Jian Cheng, WeiHong and KeWu, "Broadband Self-Compensating Phase Shifter combining delay line and quaal-length unequal-width phaser", *IEEE trans. Microw. Theory Tech.*, vol.58, no. 1, Jan.2010.