

Adaptive Closed-loop Phase Source

#Tang Chengcheng¹, Quan Xue¹

¹Department of Electronic Engineering, City University of Hong Kong
Tat Chee Avenue, Kowloon, Hong Kong
richard.tangcc@gmail.com

1. Introduction

Nowadays, more and more researchers pay attention to phased array antennas, which play an important role in the fields of radio frequency identification (RFID), radar, and wireless communications because of their wonderful characteristics of beam forming. In order to maintain good performance in phase shift and feasibility, many techniques have been applied. Such as an electronic phase control circuit for microwave system, which changes the phase velocity along a section of diode-loaded transmission line, was proposed in 1999 [1]. This technique was further developed with a microelectromechanical system (MEMS) variable capacitor diode, which takes place of transmission lines, can be processed to be a commercial integrated circuit (IC) to give us a very good performance [2]. However, this kind of phase shifter suffers from insertion loss and noise as the signal needs to pass through the phase shifter. What's more, as lossy power dividers used to provide signals to each element, signal power at each antenna element would be decreased with the increase of the number of antenna elements in array. In order to eliminate the problem of power dividing, some ideas of active phase shifters or phase control circuits are implemented in the phased source techniques, such as active phased array antenna based on DDS [3], where phased signals were provided by a direct digital signal synthesizer at low frequency and up-converted to desire high frequency; phase control was implemented at high frequency with the help of phase lock loop (PLL) [4] [5]. However, this kind of technique applies phase control through high frequency component, which is expensive and complicated. To improve the performance of both microwave phase shifter and active phase control circuit, an Indirect Controlled Phased Source (ICPS) was implemented in 2006, where phase control was realized by changing the phase of the reference signal of PLL at low frequency to give a corresponding phase shift at desire high frequency [6]. By this approach, not only the problem of lossy power dividing system can be solved, but also the complexity of phase control at high frequency can be reduced a lot.

However, as ICPS technique has an open-loop construct, it may suffer from the change of environment or acuminate noise of components as it cannot monitor the instant phase information of the output signal. In this paper, we propose an adaptive closed-loop phase source (ACPS), which is developed from the original ICPS. With the help of a novel phase detector array, the whole construct works like a PLL, i.e. it can monitor the instant phase information and lock the output signal to a certain phase. In ACPS, a varactor type low frequency phase shifter (LFPS) takes place of the 2ⁿ type one in [6] to provide a continuous phase shift. In this paper, a two-path prototype is fabricated to implement phase locking.

2. Analysis of ACPS

Fig. 1 shows a presented four-path ACPS diagram. It contains three main parts, modified ICPS unit, phase detector array and MCU.

a. Modified ICPS Unit

According to [6], ICPS unit has three main parts:

i) Crystal Oscillator

10 MHz crystal oscillator is designed in ICPS unit to provide a pure signal source to the frequency synthesizer.

ii) Low Frequency Phase shifter

In [6], a 2^n type discrete phase shifter was used, whose configuration is shown in figure 2, while in ACPS, a varactor type phase shifter is used to provide a continuous change of phase and its configuration is shown in figure 3.

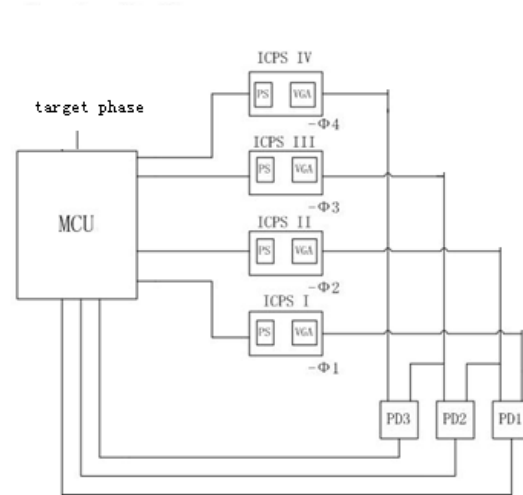

Figure 1. ACPS diagram

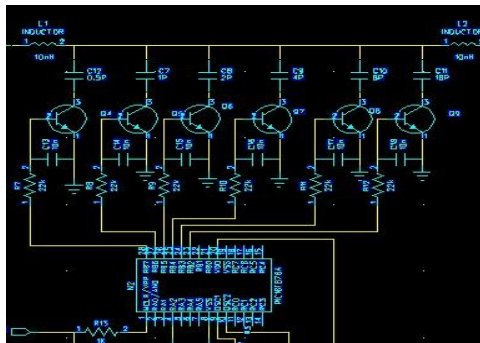

Figure 2. 2^n type LFPS

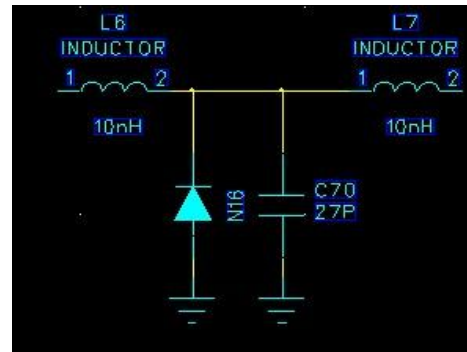

Figure 3. Varactor type LFPS

We can change the phase changing range of the varactor type LFPS by changing the value of the capacitor, which is parallel with the varactor. There is a treatment between the linearity and controlling of the varactor type LFPS. A small capacitor would give us a good linearity, but bad controlling LFPS, whose performance is shown in figure 4, while a large capacitor would give us a bad linearity but good controlling LFPS, whose performance is shown in figure 5.

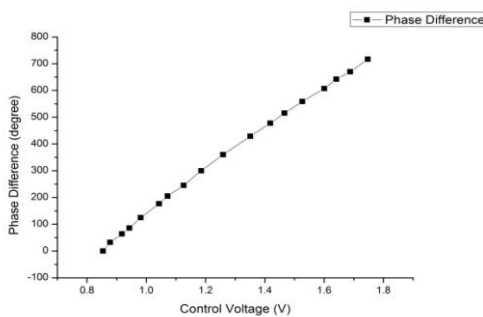

Figure 4. Cap=27Pf

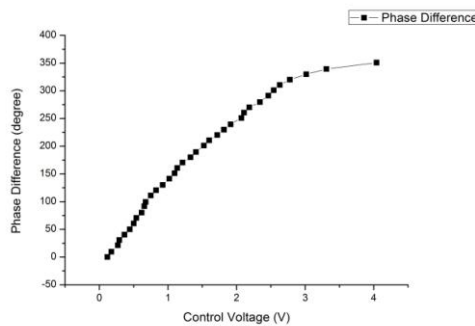

figure 5. Cap=1200 Pf

Because of the use of DSP, a nonlinear but good controlling structure is preferred.

iii) Frequency Synthesizer

The frequency synthesizer, which is made up of a PLL chip (MB15E07) and a VCO chip (MAX2750), can up convert a signal of 10 MHz from the crystal oscillator to a signal of any desired frequency with the help of MCU programming.

b. Phase Detector Array

This phase detector array consists of three pieces of phase detector chips (AD8302) with Wilkinson power dividers as the connection. It can be used to detect the phase difference between the two adjacent channels' signals. Before being used as an array, every phase detector chip should be calibrated in order to record its performance in the MCU for a later operation.

Calibration procedure is quite simple. It contains two iterative steps. The first step is to use an oscilloscope to measure the input phase difference, and the second step is to measure the output voltage value of every phase detector chip with the measured phase difference signals as the input signals. Every step counts 10 degrees' phase shift and it will repeat 36 times for a full range of phase shifting. The calibration result is shown in the following figure 6.

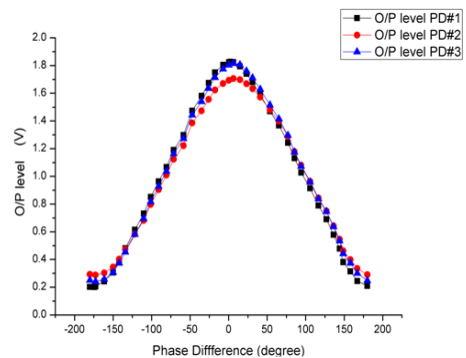

Figure 6. Performance of phase detector array

From this performance above, we can see that three phase detectors have different performance at same situation. As a result of that, all the three phase detector elements' performance should be stored as tables in the MCU for later operation. What's more, as the step size in the calibration procedure is discrete, interpolation is needed for more possible values.

c. MCU

PIC 16F876A is used in ASSA as a MCU. It controls LFPS according to the phase information in the closed-loop operation. PicBasic Pro language is used.

3. Design Example

To demonstrate an accurate phase control, a two-path prototype is fabricated. The procedure diagram of this test function is shown in figure 7.

First, a target phase difference is set to MCU. Then, the MCU would control the phase shifters in the ICPS units to give a phase close to the target phase based on the phase shifter table. Then the phase detector would read a phase difference and send the phase info to the MCU. MCU would compare the measured phase difference with the target one and then fine adjust the phase difference by tuning one phase shifter. It will repeat until the measured phase difference matches the target one.

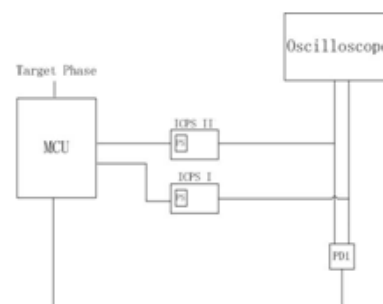

Figure 7. Procedure diagram of test function

The demonstration table is shown in figure 8.

This prototype has the following two characteristics:

1) Average Phase Reading

It is programmed to calculate an average phase difference value of every 50 times of reading. This can reduce the effect of the unstable singles due to the coupling effect.

2) Adaptive Tuning Step

It has an adaptive tuning step during the phase adjustment procedure. When the measured phase difference is far away from the target one, the MCU would tune the phase shifter at a larger step while is the measured phase difference is close to the target one, the tuning step would be reduced. This can give us a fast but careful phase control.

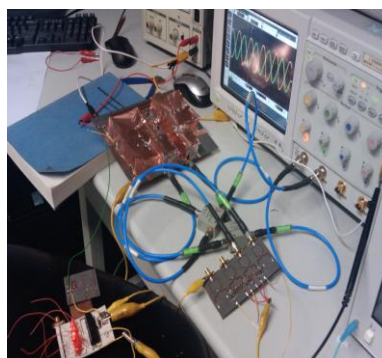

Figure 8. demonstration table

4. Conclusion

This paper has presented an adaptive closed-loop phase source. By utilizing varactor type low frequency phase shifters and phase detector array, it can provide any accurate adjacent phase difference to antenna array elements. A two-path prototype was fabricated and proved to give a fast and careful phase control. With a closed-loop construct and instant feedback, this type of phase source can not only eliminate power dividing system, but also implement the phase shift at low cost, and furthermore, provide a instant monitoring of output signal's phase information to lock the phase to a certain value.

Acknowledgments

This work was supported by Shenzhen Science and Technology Planning Project for the Establishment of Key Laboratory in 2009 (Project No.CXB200903090021A)

References

- [1] A. S. Nagra and R. A. York, "Distributed analog phase shifters with low insertion loss," *IEEE Trans. Microw. Theory Tech.*, vol. 47, no. 9, pp. 1705–1711, Sep. 1999.
- [2] N. S. Barker and G. M. Rebeiz, "Optimization of distributed MEMS transmission-line phase shifters U-band and W-band designs," *IEEE Trans. Microw. Theory Tech.*, vol. 48, no. 11, pp. 1957–1966, Nov. 2000.
- [3] J. Lu, M. Wu, X. Jin, and Z. Fang, "Active phased array antenna based on DDS," in *Proc. IEEE Int. Symp. Phased Array Syst. Technol.*, Oct. 2003, pp. 511–516.
- [4] A. W. Houghton and P. V. Brennan, "Phased array control using phaselocked- loop phase shifters," *Proc. Inst. Elect. Eng.*, vol. 139, no. 1, pp. 31–37, Feb. 1992
- [5] N. B. Buchanan and V. F. Fusco, "Triple mode PLL antenna array," in *IEEE MTT-S Int. Dig.*, Jun. 2004, vol. 3, pp. 1691–1694.
- [6] Kwun-Chiu Wan and Quan Xue, "Indirect Controlled Phase Source," *IEEE Microwave and Wireless Components Letter*, vol.16, no. 12, pp702-704, Dec. 2006