

COMPUTER-AIDED DESIGN OF ANTENNAS AND RADOMES MOUNTED
ON COMPLEX PLATFORMS AND PERFORMANCE ENHANCEMENT OF
COMMUNICATION ANTENNAS USING METAMATERIALS

Raj Mittra

Electromagnetic Communication Lab
Department of Electrical Engineering
Pennsylvania State University
University Park, PA 16802-2705, USA
rajmittra@ieee.org

1. Introduction

Recently, the advent of powerful distributed computing platforms has had a marked influence on the antenna design strategies, particularly for those mounted on complex platforms, *e.g.*, satellites, spacecrafts, aircrafts and ships. The modeling of such antennas represents a formidable challenge for several reasons: the platforms have complex material properties; the limited real estate available creates a serious compatibility problem; the frequency range over which the modeling is desired is often large; and, available commercial codes for antenna analysis are woefully inadequate. The difficulties in modeling these problems are further exacerbated by the presence of dielectric or FSS (frequency selective surface) radomes that interact with the antenna and influence the impedance and radiation characteristics of the antenna, often in a deleterious way. It is necessary to estimate these effects accurately in order to predict the system performance of the antenna complex.

In the first part of this review paper, we will discuss a number of antenna designs (see Figs. 1-6) that serve as illustrative examples of challenging problems, and then go on to describe how we might meet the challenges they presented when we attempted to model them.

Next, we will turn to the problem of analyzing and synthesizing antenna composites with metamaterial type of substrates and superstrates, used to enhance the performance of a class of planar antennas (see Figs. 7-11). Strategies for designing these types of antennas, which have drawn considerable recent attention of the antenna community, will be presented along with examples of both successful and “not so successful” designs. Guidelines for successful design of antenna-metamaterial composites will also be included in the presentation.

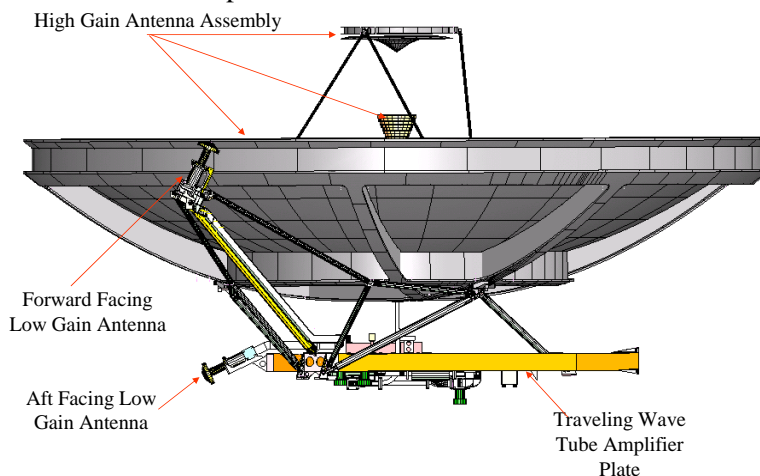

Fig. 1. Mars Reconnaissance Orbiter High Gain Antenna and Low Gain antenna Configuration (courtesy of W. Imbriale, JPL).

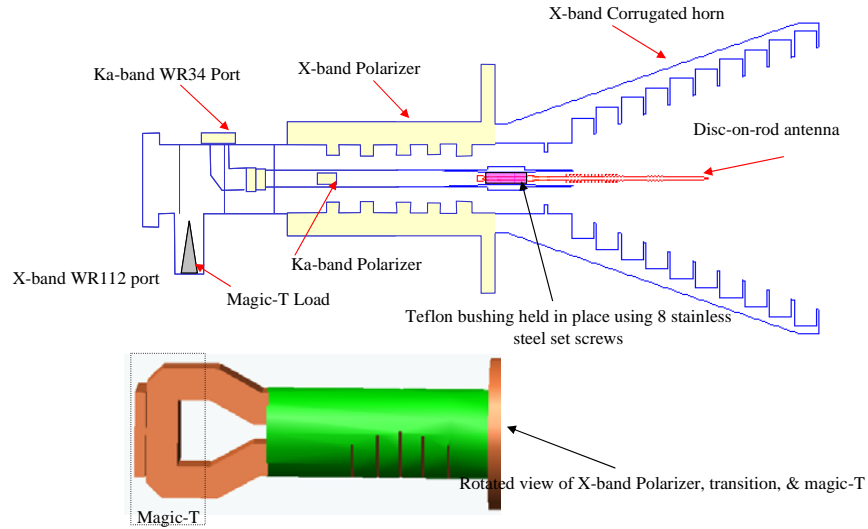

Fig. 2. Various view of X-Ka-band Feed assembly (without the long X-band and Ka-band waveguides) (courtesy of W. Imbriale, JPL).

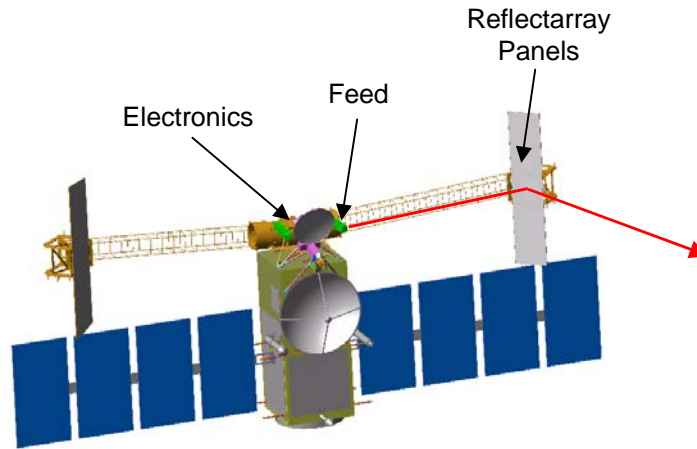

Fig 3. Illustration of offset-fed reflectarray antennas spacecraft accommodation (courtesy of W. Imbriale, JPL).

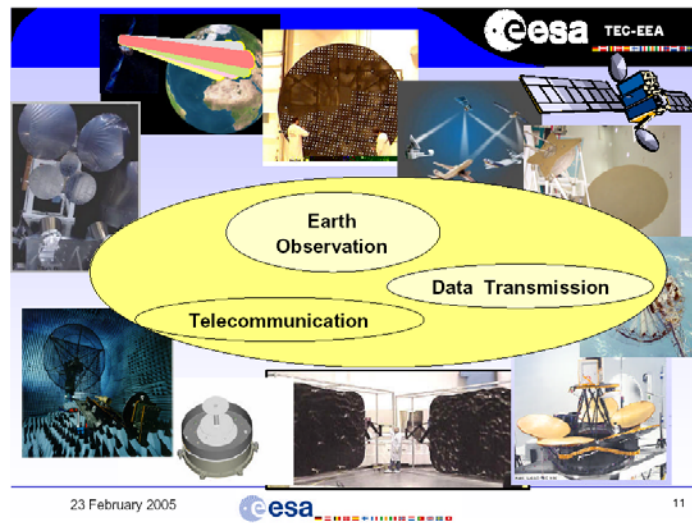

Fig. 4. ESA satellites (courtesy of C. Mangenot, P. Rinous, ESA).

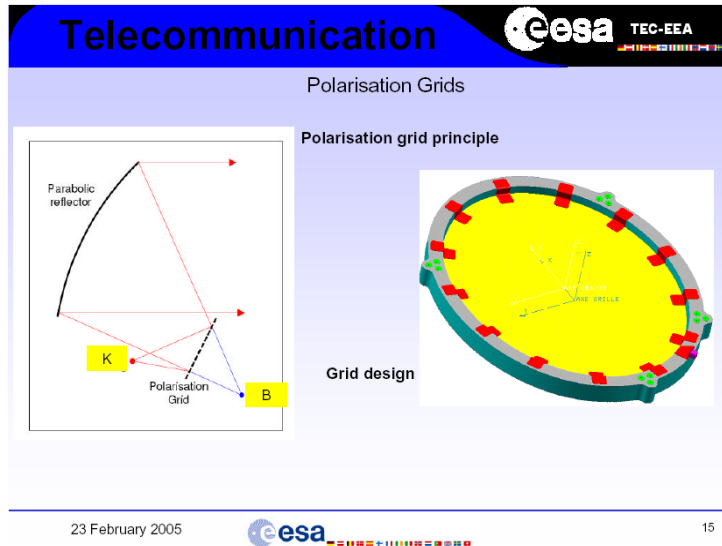

Fig. 5. Polarization grid design (courtesy of C. Mangenot, P. Rinous, ESA).

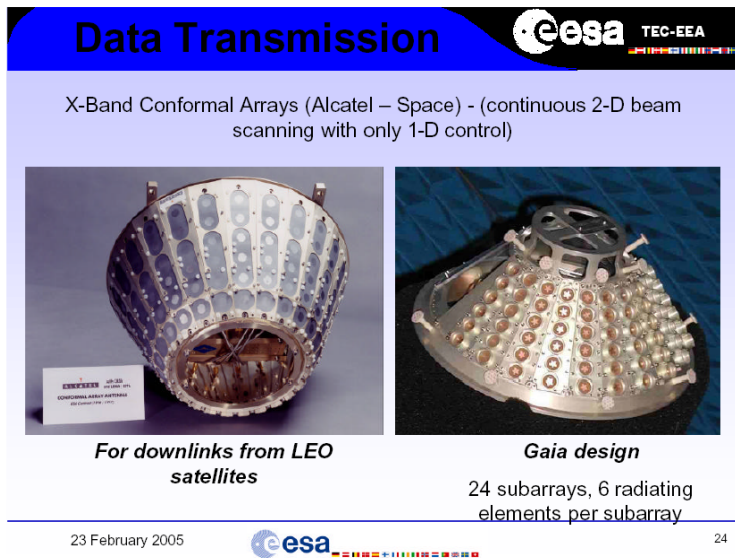

Fig. 6. Conformal arrays (courtesy of C. Mangenot, P. Rinous, ESA).

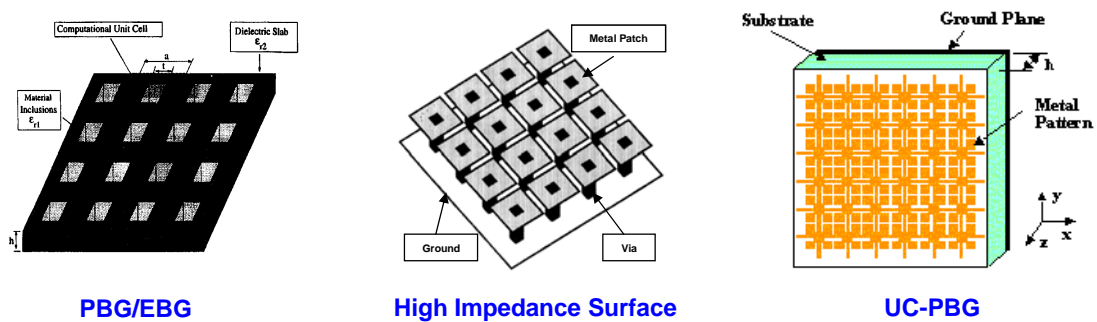

Fig. 7. Artificial Magnetic Ground Planes (AMGs). Synthesized 2-D or 3-D periodic metallic or dielectric structures to effectively impede the propagation of electromagnetic waves in a specified band of frequency.

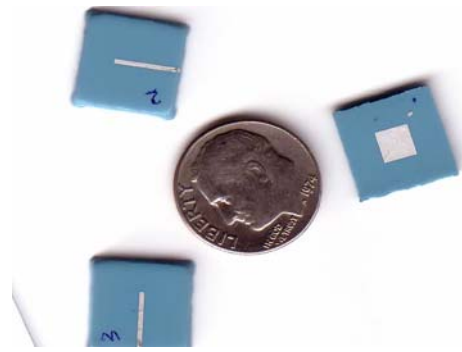

Fig. 8. Reduced size antenna realized with metamaterial loading.

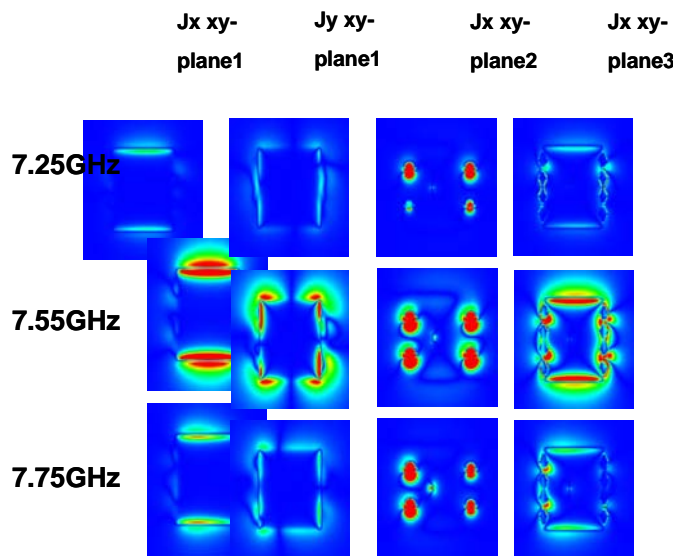

Fig. 9. Current Densities computed by using the parallelized FDTD (PFDTD) code.

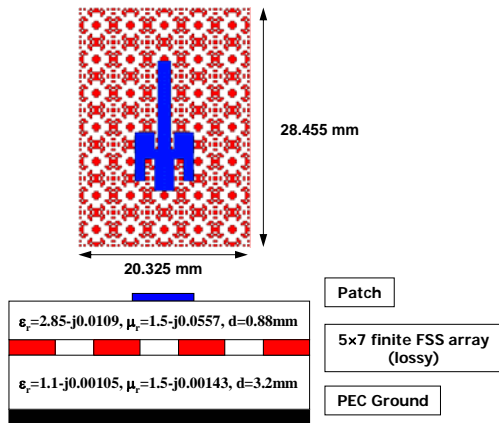

Fig. 10. Microstrip patch antenna on AMGs

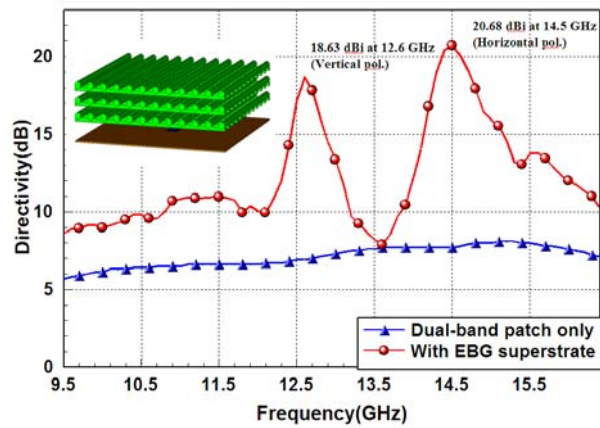

Fig.11. Directivity of the Dual-band dual polarized Patch Antenna with/without EBG Superstrate.