

A Study on Employing Diversity Reception at Base Station in Indoor Environments

Yuta TAKAGI, Ryo YAMAGUCHI, and Shinji UEBAYASHI
NTT DoCoMo, Inc.
3-5 Hikari-no-oka, Yokosuka, Kanagawa, 239-8536 Japan
E-mail: takagi@mlab.yrp.nttdocomo.co.jp

1. INTRODUCTION

Although the use of cellular phones in indoor environments has expanded, their use in some indoor environments such as medical facilities is restricted. This is due to the consideration that electric waves radiated from cellular phones impart influence to medical electronic devices. We consider that it is necessary to control the transmission power of mobile stations to achieve the minimum required level in order to reduce the influence on these electric devices in such environments. However, there is a problem in that a signal transmitted from a mobile station at the minimum required level cannot be received at a base station. To address this problem, it is important to enable the base station to receive electric waves from any location, and it is possible to improve the reception quality at the base station by taking appropriate measures in indoor environments.

The area surrounding an indoor base station comprises a multiple wave environment in which the arrival angle and polarized waves from the uplink are widely distributed. Diversity techniques such as space, site, and polarization are effective techniques that improve the reception level in such environments. In particular, polarization diversity can be achieved at the identical spot. There is almost no correlation among the branches and polarization diversity does not depend on the change in the received polarized wave when XPR is small. Recent reports indicate that electric and magnetic fields can be adopted as independent channels in environments with a wide arrival angle [1][2]. However, it is difficult in an actual situation to introduce diversity reception into indoor base station equipment because an RF transmission system that can handle the increase in the number of diversity branches and expansion of the facilities of the baseband signal processing system are required.

On the other hand, simply achieving path separation is insufficient and RAKE diversity does not effectively operate in CDMA in indoor environments because the propagation distance is generally short and the delay difference in the arrival paths is short.

As a means to address these problems, we examine a new reception system configuration that obtains a diversity gain using only one existing reception system by adding a fixed delay to the independent diversity branches and combining the branches in a RF band. This paper proposes a base station employing RAKE diversity that adopts polarization diversity in which each of the three-axis components of the electric and magnetic fields are combined with a six-branch power delay profile.

In this paper, the effectiveness of the proposed system is evaluated based on simulation and experiment. First, we calculate the fading of electric waves in an indoor environment and evaluate the transmission wave dependence on polarization for polarization diversity and space diversity. We also construct a prototype system and evaluate the characteristics. In addition, we experimentally verify the abatement of the deterioration in the reception quality using the experimental model in an indoor environment.

2. COMPOSITION AND PRINCIPLE OF SIX-BRANCH ELECTRIC AND MAGNETIC FIELD DIVERSITY RECEPTION METHOD

Figure 1 shows the configuration of the proposed system, which employs three-axis electric and magnetic field antennas and a delay power combiner system. Figure 2 shows the operating principle. The arrival angles and the polarized waves are widely distributed around the indoor base station. Since each component of the electric and magnetic fields is expected to behave independently in such an environment, electromagnetic radiation is widely distributed around the indoor base station. Moreover, since they are expected to behave independently in such an environment, each branch received by the three-axis electric field magnetic field (EH) antenna is anticipated to have a low correlation. After a relative delay time is given to the six received waves, the electric power is combined in a RF band. Because the combined signal has the delay profile shown in Fig. 2, a diversity combination becomes possible using the RAKE receiver. In short, this system can be considered to convert the polarization diversity into time diversity. The

proposed system is advantageous in that it can be constructed using one receiver even if the proposed system employs multiple antennas because the electric power is combined in the RF band.

3. SIMULATION

3.1. Evaluation method

We evaluated the diversity reception characteristics under the influence of fading generated by imaginarily moving the mobile station (transmission side), as shown in Fig. 1. The evaluation procedure is described hereafter. First, an indoor environment in which fixtures and furniture are not arranged in any specific arrangement is divided into 187 blocks, and transmitted at a height of 1 m in each block. The electric wave propagation and each arrival path are calculated using the ray-trace method. Next, the change in each path is calculated using the information of each original path calculated in the case that the transmission side moves along the x-axis. Rayleigh fading is generated by multi-paths arriving from various directions. Here, the arrival direction of each path is assumed not to change. Moreover, the equal-gain combining method is used as the diversity combining method.

3.2. Reception Characteristics

The reception level characteristics were examined when a three-axis electric field antenna and a three-branch space diversity antenna were installed on the ceiling. First, when the correlation of each branch was evaluated, the results showed that the correlation between each antenna branch was low for all polarizations and blocks for each antenna (correlation value 0.25 or less). We evaluated the accumulation probability of the entire indoor environment when a vertical polarized wave and horizontal polarized wave were transmitted respectively. We paid attention to the accumulation probability at 1% of the relative reception level comparing with the reception sensitivity of the commercial base station system. This is due to that it is important that the place where the reception level in the base station reception is small is decreased in order to realize the communication by the lowest transmitting power. We also evaluated the reception characteristics for polarization diversity and space diversity when the transmission polarization was changed from vertical to horizontal as shown in Fig. 3. This figure shows that the polarization diversity has stable reception characteristics that do not depend on the polarization on the transmission side, and that space diversity greatly depends on the polarization on the transmission side. These results indicate the possibility of polarization diversity for the anticipated stable reception in an indoor environment in which various polarized waves arrive at a base station.

4. PROTOTYPE AND EXPERIMENTAL

4.1. Thee-Axis EH Antenna

Figure 4 shows the composition and the appearance of the prototype three-axis EH antenna. A dipole antenna is used as the electric field antenna and a slot antenna is used as the magnetic field antenna. For the dipole antenna, each antenna is made orthogonal by inclining it by approximately 55° and arranging them in an equilateral triangle. The slot antenna comprises a triangular pyramid using a printed wiring board in which one plane is a right-angled isosceles triangle, and a half wavelength slit is installed centering on the tangent. To secure the half wavelength length, the slit is in the shape of a hook. The size of this antenna system is 12X12X8 cm (30X30X8 cm including the ground), and is approximately 1/3 the size of a six-branch monopole antenna. To evaluate the effectiveness of this antenna, we constructed a prototype. The basic characteristics of the prototype are given below.

I. Return loss characteristic: At 1.95 GHz, the return loss for all branches is 10 dB or more and excellent results are shown.

II. Mutual coupling characteristic: Between dipole antennas this characteristic is -20 dB or less. Between slot antennas and between a slot antenna and a dipole antenna this characteristic varies, but a value of -10 dB or less is obtained in each case.

III. Radiation directivity and Radiation efficiency: The peak for the dipole antenna is directed outside (60°) although the radiation is directed downwards, compared to a general base station antenna. On the other hand, the slot antenna has a peak in the direction of the antenna ridge line. The average radiation efficiency for each branch of the constructed prototype antenna is approximately 73%. It is thought that the mutual coupling characteristic does not exhibit good performance. We could not obtain results that satisfy the expected performance level from the viewpoint of the mutual couplings and the radiation efficiency. Improvement in the antenna performance is a topic for future work.

4.2. DELAY COMBINER SYSTEM

Figure 5 shows the composition and the appearance of the delay combiner system. The signal input to each branch is the signal received from the three-axis EH antenna and the mutual correlation are low. The resonance filter is used for the delay circuit, and the delay time of each resonance filter is approximately 100 ns. The delay time of each branch can be adjusted in the range from 0-500 ns by connecting the resonance filter in series as needed. The electric power of the six branches is combined in the RF band and is output. The resolution time of the RAKE reception in CDMA (16 Mcps) is approximately 70 ns, and the delayed wave at intervals of 100 ns can be recognized as a RAKE reception wave. Moreover, an amplifier and attenuator are inserted in each branch and the level is adjusted in order to equalize the output level of each branch. Figure 6 shows the delay profile when employing the manufactured delay combiner system. The results show that the delay of approximately 100 ns occurred and that the obtained delay was according to the design.

4.3. PROPAGATION CHARACTERISTICS

We installed the three-axis EH antenna as described in Section 4.1, a six-branch monopole space diversity antenna, and a one element monopole antenna on the ceiling (shield laboratory). We evaluated the reception characteristics based on the experimental parameters given in Table I. Here, the equal-gain combining method is used as the diversity combining method. The dipole antenna (VF, HF) was connected to the transmitter while the mobile station was used. The experimental area, a hallway in the laboratory, was divided into 50 blocks, and the transmission was measured while walking at random in each block of the experimental area. The fixtures, furniture, and measuring instruments in the experimental area were assumed to be untouched. First, when the correlation of the branches of the proposed antenna was evaluated, the results showed that the correlation between each antenna branch was low for all polarizations and blocks (correlation value 0.3 or less).

Next, we evaluated the reception characteristics. Here, we evaluated the relative reception level at the base station and the diversity gain at the accumulation probability of 1%. The relative reception level is set by adding noise to the base station reception level obtained for the measurement off-line. Figures 7(a) and 7(b) show the cumulative probability of the laboratory when the vertical and horizontal polarized waves (x axis) are transmitted, respectively. Figure 7(b) shows that the proposed antenna obtains the average diversity gain of -2 dB compared to the six-branch space diversity antenna. We consider that the reception signal level decreased because the radiation efficiency of the constructed antenna was low and the environment we measured was where sub polarized wave components were large. These results indicate the effectiveness of the abatement of the relative reception level deterioration using the proposed system in an indoor environment.

5. CONCLUSION

We examined the method for configuring a diversity reception system to improve the reception quality of the base station in indoor environments and to achieve a decrease in the transmission power from a mobile station. We proposed a polarization reception method that combines each of the three-axis components of electric and magnetic fields with the RAKE reception of a six-branch delay power combined system applying the RAKE scheme. First, we evaluated the dependence on polarization of the transmission wave for polarization diversity and space diversity based on simulations and we confirmed the possibility of the polarization diversity. Next, we constructed a prototype system and evaluated the characteristics. As a result, we confirmed that it is possible for each antenna of the three-axis EH antenna to work well on the whole as a diversity branch in the same location, and the delay profile of the delay combination system worked fairly well according to the design. In addition, we experimentally verified the abatement of the deterioration of the reception quality when using the experimental model in an indoor environment. As a result, we abated the deterioration in the relative reception level in an indoor environment by combining the delay combination system with the three-axis EH antenna.

As a future project, we plan to improve the antenna performance and downsize the antenna. Furthermore, we plan to verify the improvement in the reception quality degradation including the delay combination system.

REFERENCES

- [1] T. Svantesson, et. al., "Analysis of Electromagnetic Field Polarizations in Multiantenna Systems," *IEEE Trans. Wireless Commun.*, vol. 3, pp. 641–646, Mar. 2004.
- [2] R. A. Andrews, et. al., "Tripling the capacity of wireless communications using electromagnetic polarization," *Nature*, vol. 409, pp. 316–318, Jan. 2001.

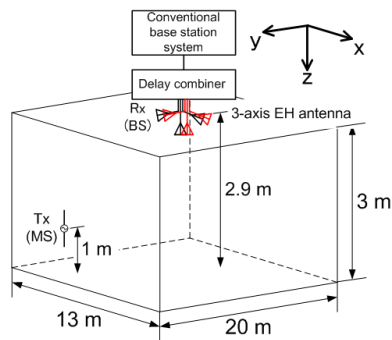

Fig. 1 Configuration of proposed system

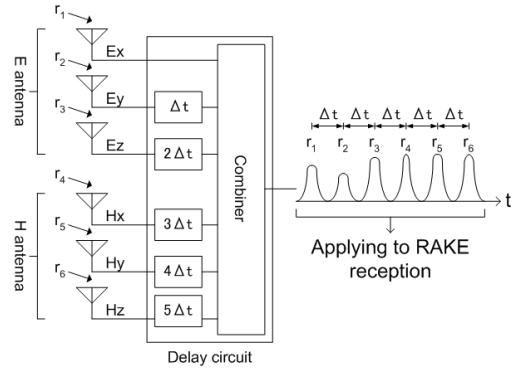

Fig. 2 Principle behind proposed system

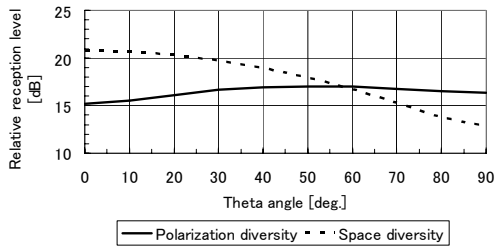

Fig. 3 Dependence on polarization of Tx

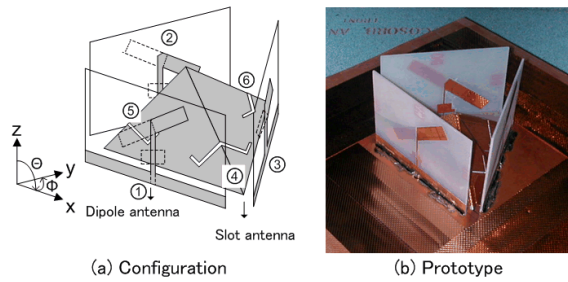

Fig. 4 3-axis EH antenna

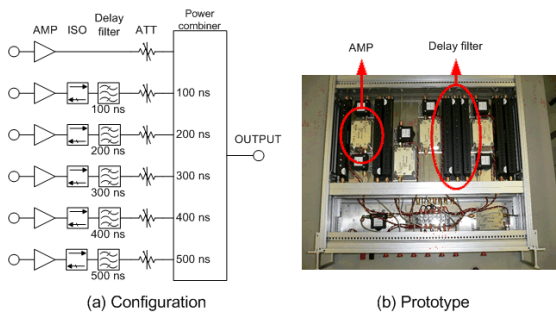

Fig. 5 Delay combiner system

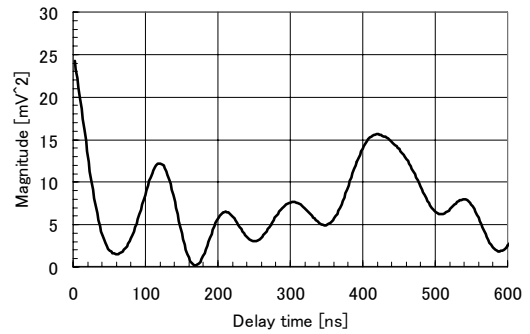
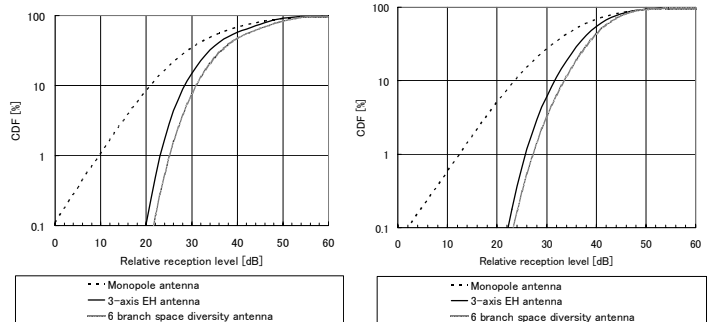

Fig. 6 Delay profile

Table I. Experimental parameters

Frequency	1950 MHz (CW)
Polarization	Vertical, Horizontal (x-axis, y-axis)
Tx antenna	Dipole antenna
Rx antenna	3-axis EH antenna
	6-branch monopole space diversity antenna
	Monopole antenna
Height of antennas	Tx: 1 m, Rx: 2.9 m
Measured range	1.2 m × 1.2 m × 50 blocks
Measured time	20 s
Measured route	Random walking pedestrian
Measured environment	Laboratory (13 m × 20 m × 3 m)



(a) Vertical (b) Horizontal (x-axis)
Fig. 7 Accumulation probability