

# Triple-band LTCC Chip Antenna using Stacked Meandered Lines for Mobile Communication System

Ho-Yong Kim, Young-Do Kim, Hyoung-Jun Lim, Hong-Min Lee  
Department of Electronics Engineering Kyonggi University  
Yi-ui dong, Young-tong gu, Suwon-Si, Kyonggi-do, Korea  
E-mail: hyounran@hanafos.com

## 1. Introduction

In recent years, with the advance of new technology, the demand for an antenna operating at multi-bands is increasing rapidly. The multi-band antennas which are used in mobile communication hand-set, require much more space in system. Therefore compact internal multi-band antenna design becomes the hot topic in order to realize the small and light antennas. The stacked patches structure and multi-current paths techniques are useful methods for achieving multi-band antenna, but it is difficult to adjust frequency ratio and achieve good return-loss.<sup>[1-4]</sup> In this paper, we propose a novel triple-band antenna using LTCC (Low Temperature Co-fired Ceramic) multi-layer technology. The low-profile meander lines are stacked on LTCC substrate to achieve minimization of occupied space of the proposed triple-band antenna. The experimental result shows that the proposed antenna achieves available radiation pattern, frequency ratio, and good return-loss.

## 2. Antenna Design

The meander line radiation structure, which is one of electrically small antennas extends effective current path of the antenna, the miniaturization of antenna size can be achieved easily. As changing the width of ground, the maximum length of the antenna is varied also, so the impedance bandwidth and gain are affected. Therefore, in the design of proposed antenna the substrate size of the common mobile communication handset ground plane environment are considered.

The figure 1(a) shows ground environment. The dimension of FR-4 substrate is  $80\text{mm} \times 40\text{mm}$ , ground plane is  $40\text{mm} \times 50\text{mm}$  and the dielectric constant of FR-4 is 4.4. The figure 1(b) shows the structure of proposed antenna which is mounted on FR-4 substrate. The dimension of proposed antenna is  $12.5\text{mm} \times 20\text{mm} \times 1\text{mm}$ . The proposed antenna consists of three meandered lines on LTCC multi-layer. The dielectric constant of LTCC multi-layer is 7.8. The three meandered lines are designed in order to cover the GPS, PCS and satellite DMB frequency bands. The GPS and PCS meandered lines are connected by via 1. The diameter and height of via 1 are 0.12 mm and 0.2mm. The PCS and satellite DMB meandered lines are connected by via 2. The diameter and height of via 2

are 0.12mm and 0.3mm. When the antenna radiating elements are stacked vertically, the frequency ratio of the antennas is reduced by the mutual coupling effect. Therefore the GPS and PCS meandered lines should be arranged carefully for reducing this coupling effect. If Satellite DMB meandered line affects GPS meandered line, the proposed antenna shows bad return-loss, so the impedance matching of satellite DMB-band will be difficult. The PCS and Satellite DMB meandered lines are stacked vertically also for reducing effect on GPS meandered line, therefore the field is concentrated between PCS and Satellite DMB meandered lines. The Couplings are adjusted by two vias and for the improving frequency ratio and return-loss of the antenna three meander lines arrangement are adjusted. The figure 2 shows surface currents on the radiating elements at each of resonance frequencies. The figure 2(a) shows flow of surface current on the effective current path of GPS meandered line at 1.592GHz. The figure 2(b) shows little coupling between GPS and PCS meandered lines at 1.816GHz. The figure 2(c) shows concentrated filed between PCS and satellite DMB meandered lines. We can verify the coupling effect between satellite DMB and GPS meandered lines is reduced

### 3. Experimental results

The figure 3(a) shows return loss of simulated antenna. The return loss of simulated antenna achieve suitable frequency ratio, applicable impedance bandwidths in GPS/PCS/satellite DMB systems. The figure 4 shows the photos of fabricated antenna using LTCC technology. The used green sheets are DP9599 of Dupont. The dielectric constant of green sheet is  $7.8 \pm 1$ . The dimension of fabricated antenna is  $12.52mm \times 19.95mm \times 1.05mm$ . The figure 3(b) shows return loss of measured antenna and simulated antenna. The resonance frequencies of measured antenna shift to upper frequency(about 20MHz). Because variable factors of fabricated antenna are error of fabrication, effective dielectric constant, and shrinkage conductor. But the fabricated antenna improve return-loss and frequency ratio. The resonance frequencies are 1.696GHz, 1.888GHz, and 2.680GHz. The impedance bandwidths ( $VSWR \leq 2$ ) are 150MHz, 120MHz and 60MHz. The figure 5 shows radiation patterns of proposed antenna. The maximum gains are 0.08dBi, 1.70dBi and -1.27dBi at resonance frequencies.

### 4. Conclusion

In this paper, we propose a novel triple-band antenna using stacked three meandered lines and two vias with LTCC technology. The arrangement of each meandered lines is optimized for adjusting the coupling of each antenna element. The proposed antenna has a small size( $12.52mm \times 19.95mm \times 1.05mm$ ), applicable frequency ratio, the impedance bandwidths and gain. The measured radiation patterns of this antenna are quasi monopole. The structure of proposed antenna will be applied for the multi-band mobile communication antenna systems.

### Acknowledgements

This work was supported by grant NO. (2004-043-0) from Research program of the Korea Sanhak foundation.

## 5. Reference

- [1] K. Young-Do, K. Myoung-seok, K. Ho-yong, L. Hong-min, "Dual-Band Chip Antenna Using LTCC Multilayer Technology for Mobile Communication Applications," 2004 IEEE AP-S
- [2] Gwo-yun Lee, Wen-shyang Chen, and Kin-Lu Wong, "A dual-frequency triangular chip antenna for w-LAN operation," Microwave and optical technology letters, Vol. 38, No. 3, August 5 2003
- [3] C. R. Rowell and R. D. Murch, "A compact PIFA suitable for dual-frequency 900/1800-MHz operation," IEEE Trans. Antennas Propagat., vol. 46, pp. 596-598, Apr. 1998.
- [4] W. P. Dou and Y. W. M. Chia, "Novel meandered planar inverted-F antenna for triple-frequency operation," Microwave opt. Technol. Lett., vol. 27, pp. 58-60, Oct. 2000.

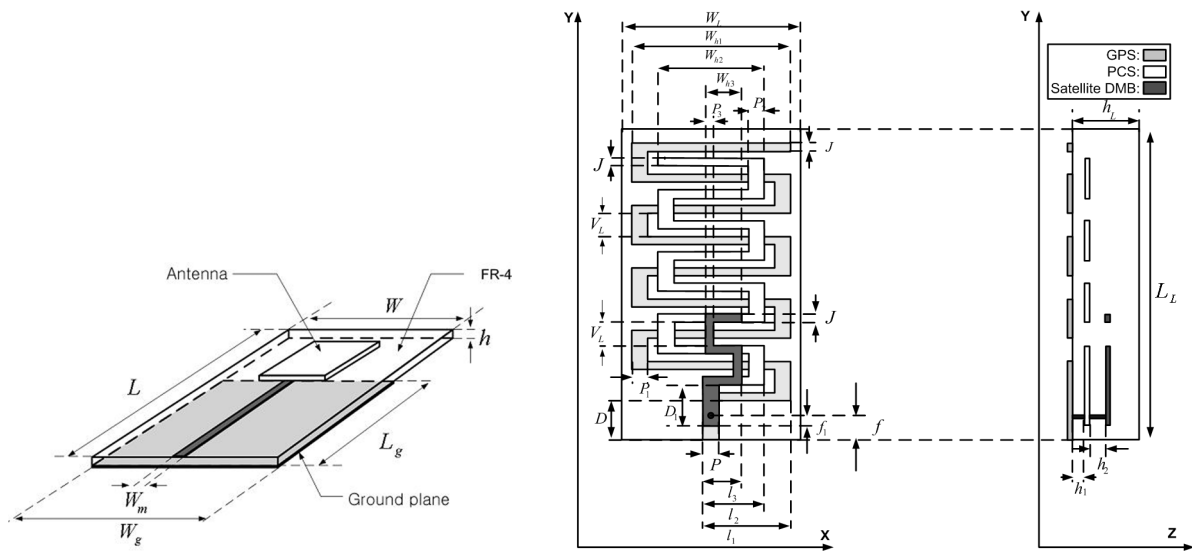

(a) Ground environment

(b) Structure of proposed antenna

$L = 80\text{mm}$ ,  $W = 20\text{mm}$ ,  $h = 0.8\text{mm}$ ,  $W_m = 1.5\text{mm}$ ,  $L_g = 50\text{mm}$ ,  $W_g = 40\text{mm}$ ,  $W_L = 12.5\text{mm}$ ,  $L_L = 20\text{mm}$ ,  
 $h_L = 1\text{mm}$ ,  $W_{h1} = 10.5\text{mm}$ ,  $W_{h2} = 6.3\text{mm}$ ,  $W_{h3} = 1.8\text{mm}$ ,  $J = 0.4\text{mm}$ ,  $V_L = 1.6\text{mm}$ ,  $P, P_1, P_2 = 1\text{mm}$ ,  $P_3 = 0.4\text{mm}$ ,  
 $D = 2\text{mm}$ ,  $D_1 = 2.1\text{mm}$ ,  $f = 1.4\text{mm}$ ,  $f_1 = 0.5\text{mm}$ ,  $l_1 = 5.75\text{mm}$ ,  $l_2 = 3.65\text{mm}$ ,  $l_3 = 2\text{mm}$ ,  $h_1 = 0.2\text{mm}$ ,  $h_2 = 0.3\text{mm}$

**Fig. 1** Ground environment and structure of proposed antenna

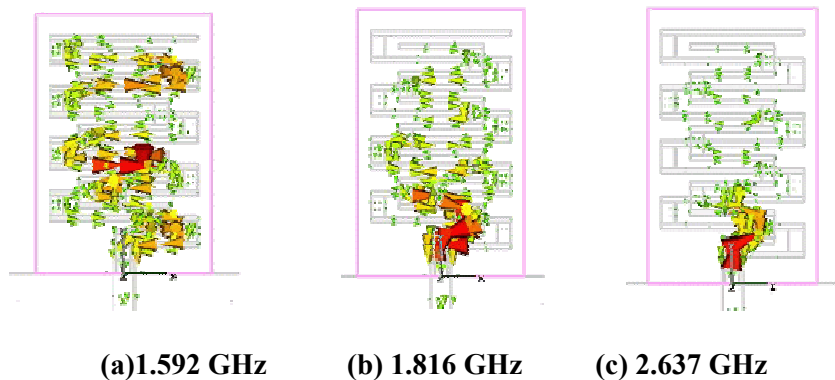

(a) 1.592 GHz

(b) 1.816 GHz

(c) 2.637 GHz

**Fig. 2** Surface currents of proposed antenna at resonance frequencies

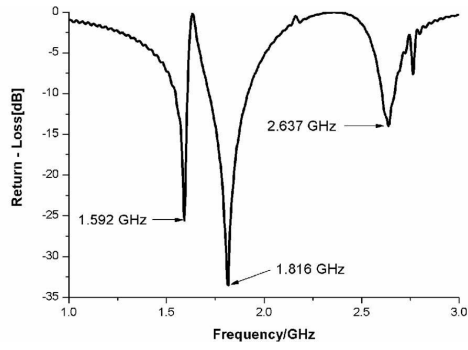

(a) Simulated antenna

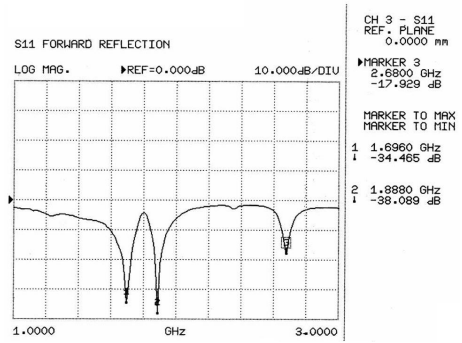

(b) Measured antenna

Fig. 3 Return loss of proposed antenna

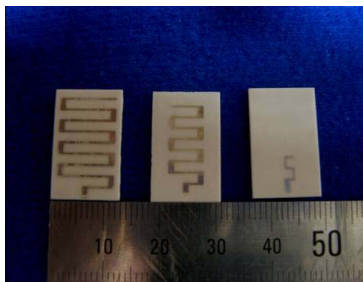

(a) Inner structure of proposed antenna

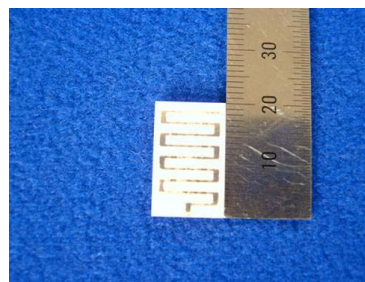

(b) proposed antenna

Fig. 4 Photo of fabricated antenna

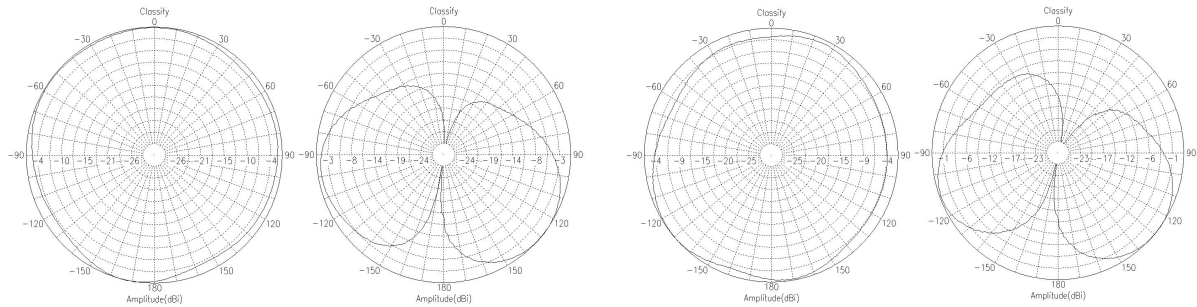

X-Z Plane

Y-Z Plane

X-Z Plane

Y-Z Plane

(a) 1.696GHz

(b) 1.880GHz

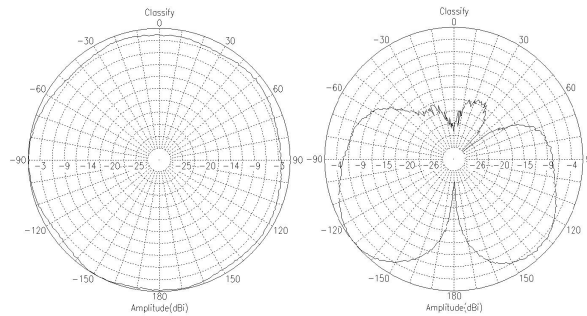

X-Z Plane

Y-Z Plane

(c) 2.680GHz

Fig. 5 Radiation pattern of measured antenna at resonance frequencies