

ULTRA WIDEBAND PRINTED MONOPOLE ANTENNA

Myungbum Kim¹, Hosung Choo², and Ikmo Park¹

¹Department of Electrical and Computer Engineering
Ajou University
5 Wonchon-dong, Youngtong-gu, Suwon 443-749, Korea
E-mail: ipark@ajou.ac.kr

²School of Electronic and Electrical Engineering
Hongik University
72-1 Sangsu-dong, Mapo-gu, Seoul 121-791, Korea

1. Introduction

Recently, there has been a great deal of interest in the design of broadband antennas for wireless communications. Various types of antennas such as biconical antennas, sleeve antennas, spiral antennas, and monopole antennas have been widely researched for broadband applications [1, 2]. Especially, the monopole type of antenna has several well-known attractive features such as its compact size, which is merely half the size of the equivalent dipole antenna, an omni-directional radiation pattern, simple design procedure, and ease of modification of radiating element to adapt to various communication system requirements. However, the major disadvantage of the typical monopole antenna is its narrow bandwidth characteristics. To date, various techniques have been carried out to improve the bandwidth of the monopole antenna [3-6]. In this paper, we propose a printed monopole using the modified ground plane to significantly increase the bandwidth of the monopole antenna for an ultra wideband application. The bandwidth of antenna can be expanded by controlling the size of the tapered slot that formed between the disk and the modified ground plane. The measured impedance bandwidth ratio of the proposed antenna is more than 30:1 for $VSWR < 2$.

2. Antenna design and results

The geometry of the proposed printed monopole antenna is shown in Fig. 1. The top portion of the ground plane, including a part of the circle with a radius R_o is etched out to form a modified ground plane. The disk and the microstrip feedline are printed on the other side of the substrate. The bottom of the disk along with a microstrip feedline is placed with a gap size of g_f from the circular arc of the ground plane. Two types of the disk, a circular disk and a rectangular disk with a half circular base, are considered in this paper. Different shapes of the upper disk cause minor changes to the return loss characteristics. However, they have more effect to the radiation pattern characteristics. For the disk shape investigated in this paper, a rectangular disk with a half circular base shows better radiation pattern characteristics than a circular disk. The radius of the circular disk is R_i , and the length and width of the rectangular disk is a and b , respectively. The vertical length of the disk is approximately 0.2λ at the starting frequency of around 0.9 GHz. This arrangement of the antenna structure generates a tapered slot between the ground plane with a circular arc and the disk. The tapered slot provides a smooth and gradual input impedance transition from the microstrip feedline to the disk. Therefore, the antenna maintains nearly constant input impedance over a wide frequency range. The antenna has two types of radiation modes, a disk mode and a slot mode. The slot mode becomes stronger as frequency increases as illustrated from the radiation patterns shown in Fig 3. The antenna is fabricated on a single piece of relatively low loss substrate with a dielectric constant of 3.38 and a thickness of 0.508

mm (RO 4003). The size of the substrate is 240 mm × 140 mm. The aluminum zig is constructed to feed the antenna with a special SMA connector by Giga Lane Inc., which maintains a return loss level of more than –20 dB from DC to 30 GHz.

Return loss measurements of antennas were carried out by using an HP 8510C vector network analyzer and radiation pattern measurements were performed in a 10 m × 10 m × 12 m anechoic chamber. The optimized design parameters of proposed antennas are listed in Table 1. All design parameters for both antennas are the same except those for a and b . Fig. 2 shows the measured return loss curves of the two antennas. The measured impedance bandwidth for VSWR<2 is from 0.94 GHz to over 30 GHz for the antenna with a circular disk and from 0.89 GHz to over 30 GHz for the antenna with a rectangular disk with a half circular base. The measured radiation pattern of the antenna with a rectangular disk with a half circular base at 1 GHz, 3 GHz, 5 GHz, and 7 GHz is shown in Fig. 3. Both co- and cross-polarized components of the xz-plane and yz-plane cuts are plotted in the same figure. The radiation patterns in the xz-plane and yz-plane cuts show a relatively good conical beam pattern up to 3 GHz. The back radiation and cross polarization level, however, goes up as the frequency increases. The measured gains of the antenna at 1 GHz, 3 GHz, 5 GHz, and 7 GHz are 3.43 dBi at $\theta=55^\circ$, 4.87 dBi at $\theta=40^\circ$, 4.42 dBi at $\theta=72^\circ$, and 7.47 dBi at $\theta=55^\circ$, respectively.

3. Conclusions

A novel ultra wideband printed monopole antenna was proposed, fabricated and measured. The proposed antenna can improve the bandwidth characteristic with the taper slot structure formed by a modified ground plane and disk element. The measured impedance bandwidth ratio of the antennas are more than 30:1 for VSWR<2.

References

- [1] W. L. Stutzman and G. A. Thiele, *Antenna Theory & Design*, John Wiley & Sons, New York, 1998.
- [2] G. Kumar and K. P. Ray, *Broadband Microstrip Antennas*, Artech House, Norwood, MA, 2003.
- [3] J. H. Johnson and Y. Rahmat-Samii, "The tab monopole," *IEEE Trans. Antennas Propagat.*, vol. 45, no. 1, pp. 187-188, Jan. 1997.
- [4] S. Y. Suh, W. L. Stutzman, and W. A. Davis, "Multi-broadband monopole disc antennas," *IEEE AP-S int. Symp. Digest*, vol. 3, pp. 616-619, June 2003.
- [5] J. Liang, C. C. Chiau, X. Chen, and C. G. Parini, "Printed circular disc monopole antenna for ultra wideband applications," *Electron Lett.*, vol. 40, no. 20, pp. 1246-1247, Sept. 2004.
- [6] Z. Wu, P. Sevret, and M. J. Ammann, "Broadband dual-plate monopole antenna," *IEE International Conf. Antennas Propagat.*, vol. 2, pp. 493-495, 2003.

Table 1. Optimized design parameter of the antenna (in mm).

Parameter	R_i	R_o	a	b	g_1	h_1	h_2	h_3	t	w_f
Value	30	40	30	60	0.3	45	15	80	0.508	1.15

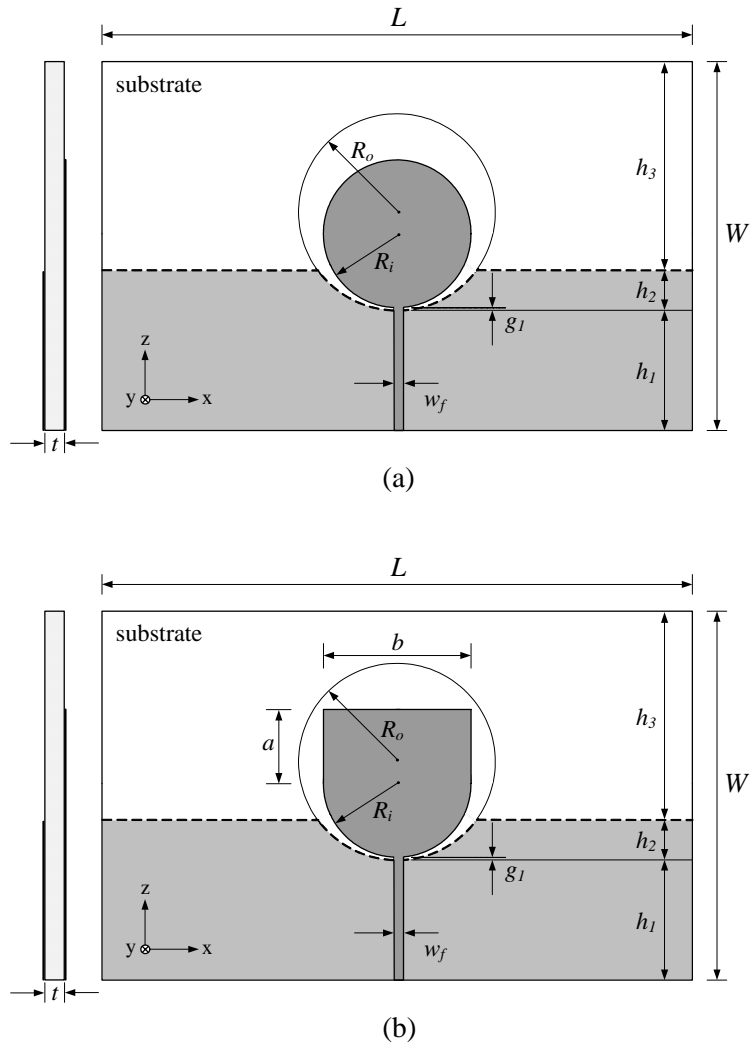

Fig. 1. Proposed antenna structure; (a) circular disk, (b) rectangular disk with circular base.

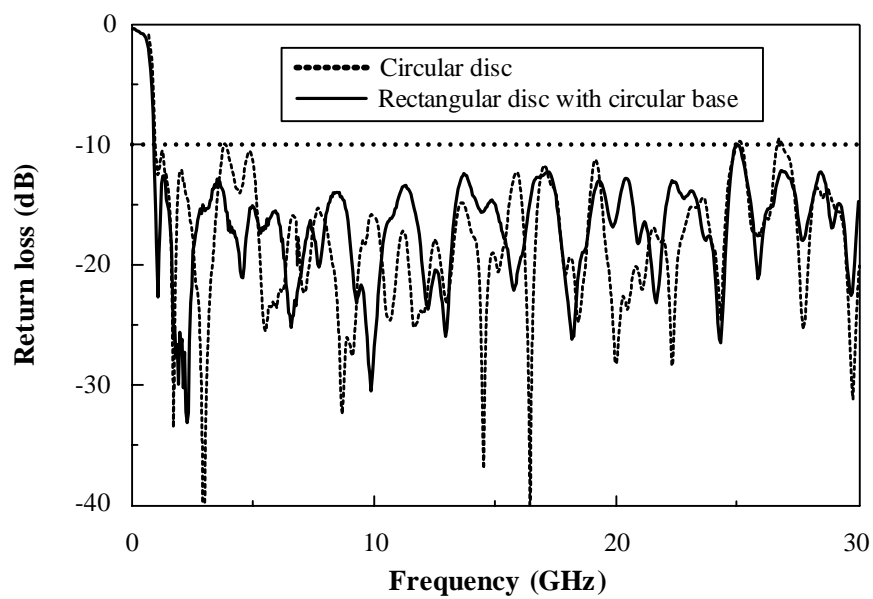
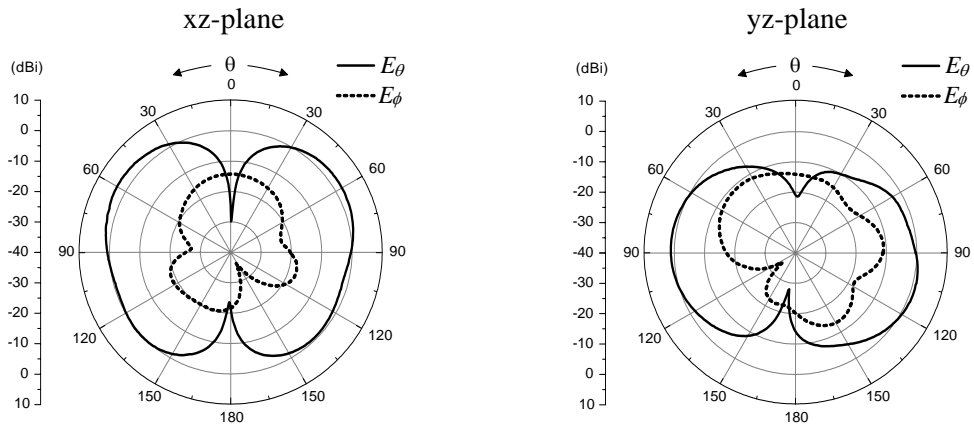
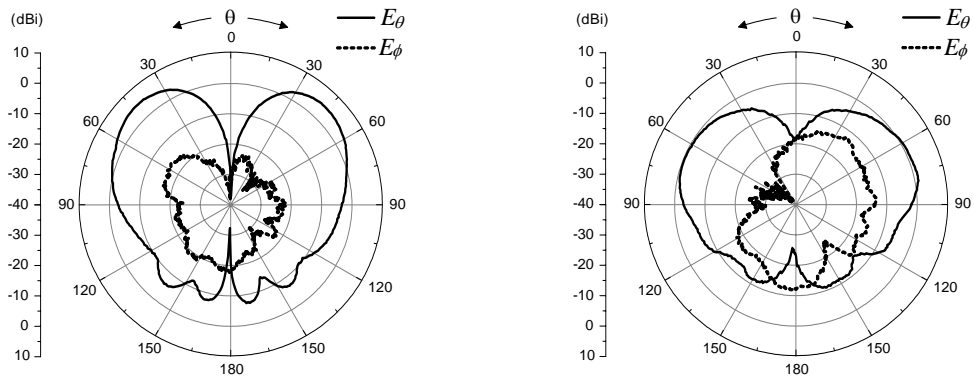

Figure 2. Measured return loss.



(a) 1 GHz



(b) 3 GHz

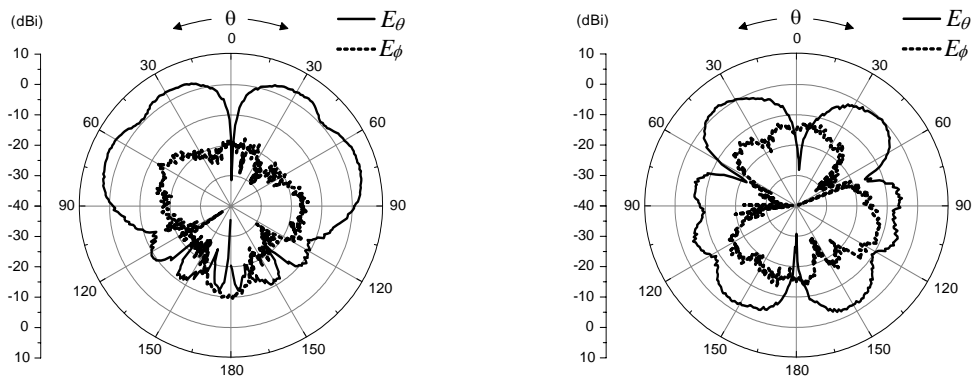

(c) 5 GHz

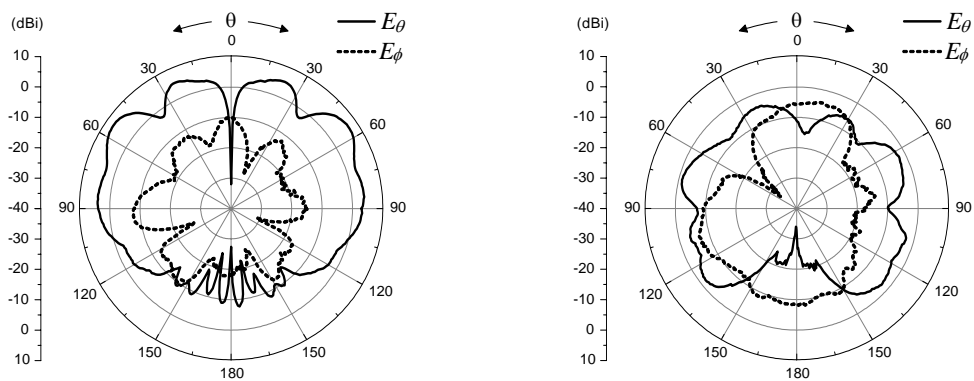

(d) 7 GHz

Figure 3. Measured radiation pattern.