

A Dual Polarization Microwave Power Transmission System for Microwave Propelled Airship Experiment

Y. Fujino*¹, M. Fujita*¹, N. Kaya*², S. Kunimi*³,
M. Ishii*³, N. Ogihara*⁴, N. Kusaka*⁵ and S. Ida*²

*¹ Communications Research Laboratory, Tokyo 184, Japan.

*² Kobe University, Kobe 657, Japan.

*³ Nissan Motor Co. Ltd., Tokyo 167, Japan.

*⁴ Saitama Institute of Technology, Saitama 369-02, Japan.

*⁵ Musashi Institute of Technology, Tokyo 158, Japan.

1. Introduction

Microwave power transmission is a strong candidate as a means of energy supply to an unmanned stationary platform flying around 20 km altitude for radio relay, environmental monitoring and other applications [1][2][3]. To show a technical feasibility of the platform and microwave power transmission technique, a demonstration experiment with an airship, which is a candidate for the stationary platform, was carried out as a cooperative research between Communications Research Laboratory(CRL), Kobe University and other two organizations. The project was named Energy Transmission toward High altitude long endurance airship Experiment (ETHER). For the joint research, CRL and Kobe University developed a microwave power transmission system consisting of transmitting and receiving systems.

Using a microwave transmitted power, we drove the motor on the airship and succeed a stationary flight of the airship. In this paper, we report mainly on a rectenna development including characteristics of the microwave transmitting and receiving system.

2. Outline of the power transmission system for ETHER

Figure 1 shows a concept of ETHER. The airship used in the ETHER project, called the HALROP-16 (High Altitude Long Range Observation Platform 16), was 16 m long and had a maximum diameter of 6.6 m [4], which was designed by Mechanical Engineering Laboratory. The airship was designed to fly only when propulsion power was applied to it. Electricity to drive the airship's two motors was to be transmitted by microwaves from the ground. The microwave transmitting system was consisting of a parabolic reflector antenna of 3 m in diameter and two 5-kW, 2.45-GHz magnetron oscillators [5]. The antenna had two feeding ports for orthogonally polarized dual polarizations, and each oscillator was connected to one of the ports to transmit 10 kW of microwave power. The dual polarization transmission system was used to double the power flux density and to keep the output power stable even when the attitude of the airship varied with time. The transmitting antenna was designed to concentrate 70% of the transmitted energy (i.e. 7 kW) within a 3-m diameter area at the distance of 50 m, which was the planned flight altitude of the airship. Since the RF-DC conversion efficiency of a rectenna was confirmed to be approximately 70% in the preliminary experiment [2], a DC

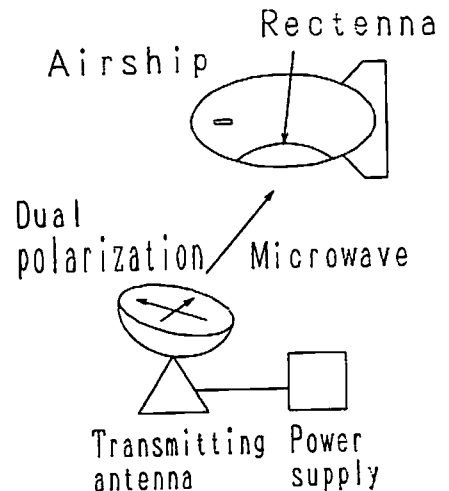

Figure 1. Conceptual sketch of ETHER.

output power of 5 kW was expected. A rectenna array was attached to the bottom of the airship for microwave power reception from the ground.

3. Design of the rectenna

The rectenna must be thin and lightweight for mounting beneath the airship. We designed a rectenna element as shown in Fig. 2 to meet these requirements. A circular microstrip patch antenna (CMSA) was used as an antenna element of this rectenna. The antenna was fed at two points for dual polarization reception. An individual rectifying circuit was coupled to each feed point. Figure 2 also shows the rectifying circuits named Type A and Type B for orthogonal polarization components. A microwave received by the antenna element is at first fed to an input filter. After passing through the input filter, it is rectified by a diode connected between a microstrip line and a ground plane. A GaAs Shottky diode of its breakdown voltage of 60 V and total capacitance of 2.4 pF, was chosen as a rectifier. The rectifying circuit was adjusted to obtain the maximum RF-DC conversion efficiency by changing a position of the diode and the filters in the microstrip line.

The average output power of each rectifying circuit was 2.5 W. The rectenna had two rectifying circuits for dual polarizations, hence it could provide an output of 5 W. Therefore, 1000 rectenna elements were needed for a 5-kW output rectenna array. We made total of 1200 elements, including 200 for reserve. The array distance between adjacent rectenna elements in a rectangular arrangement was chosen to be 0.7 wavelengths. To mount this big rectenna array beneath the airship, the array was divided into 60 subarray panels each containing 20 elements to allow easy handling. To provide a required voltage for driving electric motors, four rectenna elements (eight rectifying circuits) were connected in parallel, and then the five sets were connected in series within each subarray panel.

A measurement of an RF to DC conversion efficiency of each panel was carried out in a radio anechoic chamber. Figure 3 shows a block diagram of the measurement. For microwave generation, we used a TWTA and a magnetron oscillator with outputs of 500 W and 840 W, respectively. The outputs of these transmitters were supplied to horn antennas, each of which was for V or H polarization, fixed next to each other, facing the rectenna

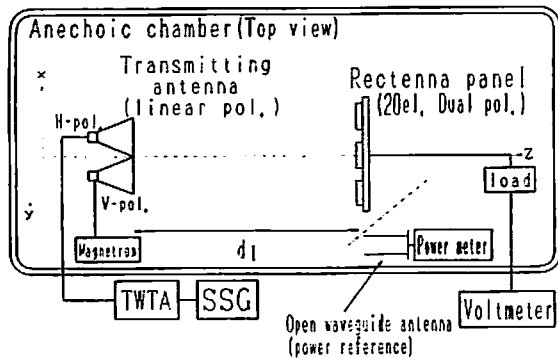
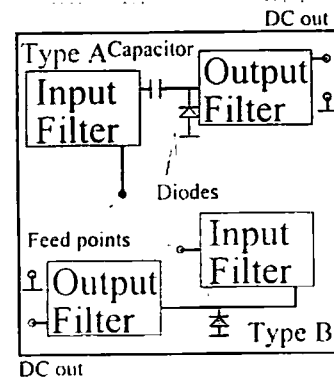
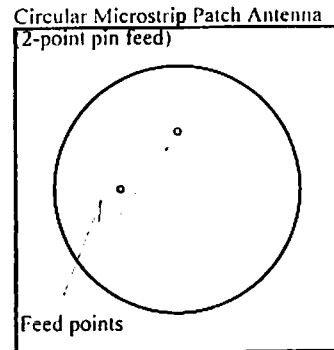

Figure 3. Block diagram for measuring the conversion efficiency in the dual polarization environment.

Front view



Rear view

Figure 2. Configurations of the dual polarization patch rectenna.

to generate the dual polarized microwaves. A distance between the transmitting antennas and the rectenna was 1.9m. The RF to DC conversion efficiency was determined as a ratio of an input RF power and a DC output power of the rectenna. The input power was calculated from the physical area of the rectenna and the input power flux density. The power flux density was measured by using an open-ended

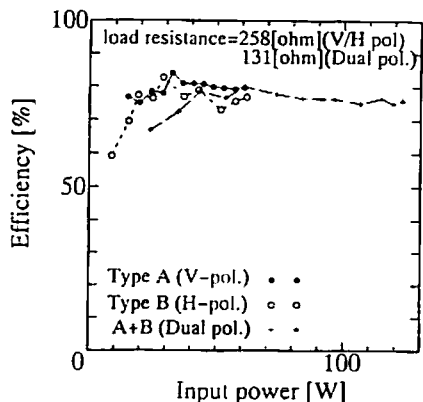

Figure 4. Conversion efficiency versus input power for the 20-element rectenna panel.

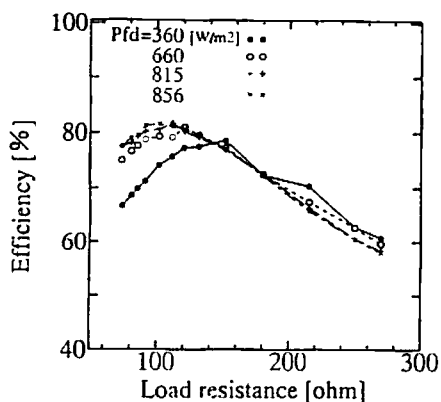

Figure 5. Conversion efficiency versus load resistance for the 20-element rectenna panel.

waveguide on the surface where the 20-element rectenna was to be placed.

Figure 4 shows the conversion efficiency versus input power of one subarray panel for each polarization component. Type A exhibits a higher efficiency than Type B, with a difference of around 2–3%. The efficiency varied from 75 to 80%, which met the requirement of the ETHER project. Figure 5 shows the conversion efficiency versus load resistance in the dual polarization environment at four different power flux density conditions. Maximum efficiency is 81% when the load resistance is 100 Ω. With this load resistance, however the efficiency decreases rapidly with a decrease in the input power. To improve the efficiency in the low power region, we set the load resistance to 130 Ω, yielding the constant efficiency characteristics against the variation in the input power as shown in Fig. 4. The load resistance for a subarray panel was thus determined to be 130 Ω.

The measurement was repeated for all rectenna panels. A simple summation of the output power from 60 panels gave 5.88 kW. Also, when we tested all the panels at the same time, a total power of 3 kW was observed. The rectenna efficiency in the working condition was estimated to be more than 70%, including the reduction of the efficiency which results from the difference in operation condition for each rectenna [6]. Outer view of the fabricated rectenna array (2.7 m height and 3.4 m width) is shown in Fig. 6. Total weight of the rectenna array 22.8 kg, hence a weight power ratio of the present rectenna was 3.8 g/W. This value was one-third that of our previous rectenna for the airplane experiment [3].

4. ETHER demonstration

ETHER demonstration was held on October 16 th, 1995 in CRL Kansai Advanced Research Center, Kobe using the microwave power transmission system mentioned above. Airship motors were driven strongly and it was ascended by microwaves from 35m to 45m above the transmitter. We succeeded in the continuous flight for three minutes at one point in the first trial (Figure 7). Also, the airship stayed at the almost same position for two minutes and half continuously, and four minutes and fifteenth second intermittently in the second trial.

5. Summary

We reported the microwave power transmitting system and receiving system for microwave propelled airship experiment (ETHER). A dual polarization microwave transmitting system was constructed using two 5-kW magnetron oscillators and a 3m ϕ parabolic antenna. For microwave power reception, we developed a thin, light weight, high-power rectenna, and its maximum conversion efficiency was 81%. A weight power ratio of the rectenna developed for ETHER project was 3.8 g/W which was one-third of our previous model.

Acknowledgment

The authors thank Dr. Masahiko Onda of the Mechanical Engineering Laboratory, and Kazumasa Tomita and Mamoru Yamada of A.E.S. Co., Ltd. who developed and operated the airship in this experiment. The authors thank Dr. Kazuaki Kawabata of Toshiba Co. Ltd. for his advice in developing the rectifying circuit.

References

- [1] W.C. Brown, "The history of power transmission by radio waves.", *IEEE Trans. Microwave Theory Tech.*, Vol. MTT-32, No.9, pp.1230-1242, Sept., 1984
- [2] T. Ito, Y. Fujino and M. Fujita, "Fundamental experiment of a rectenna array for microwave power reception.", *IEICE Trans. on Communications*, Vol.E76-B, No.12, pp.1508-1513, Dec., 1993
- [3] Y. Fujino, T. Ito, M. Fujita, N. Kaya, H. Matsumoto, K. Kawabata, H. Sawada and T. Onodera, "A rectenna for MILAX", *Proc. of 1st Wireless Power Transmission Conference*, Texas, Feb., 1993.
- [4] M. Onda, K. Hayashi, M. Misawa, M. Fujita, Y. Fujino, N. Kaya, K. Tomita, M. Yamada, O. Imaizumi and M. Sasuga, "Primary tests on ground-to-airship microwave power transmission for the future stationary high-altitude platform.", *Proc. of 2nd. Wireless Power Transmission Conference*, Kobe, Oct., 1995.
- [5] N. Kaya, S. Ida, Y. Fujino and M. Fujita "Transmitting antenna system for ETHER air-ship demonstration", *Proc. of 2nd. Wireless Power Transmission Conference*, Kobe, Oct., 1995.
- [6] R.J. Gutmann and J.M. Borrego, "Power combining in an array of microwave power rectifiers", *IEEE Trans. on Microwave Theory Tech.*, Vol. MTT-27, No.12, pp.958-970, Dec.1979.

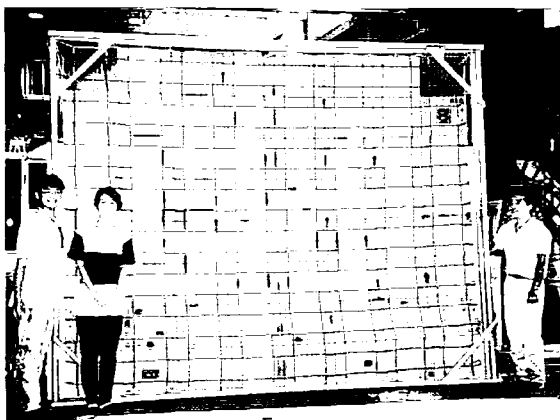

Figure 6. Outer view of the 1200-element rectenna array.



Figure 7. Airship is staying in the air by microwave power.