

Performance of WCDMA Downlink FDD Mode at 10 MHz Bandwidth

Suyeb Ahmed khan^{*}, Jasvir Singh^{**}, Mahmood Mian^{***}

^{*} Research Scholar, ^{**}Deptt. of Electronics Technology, GND University, Amritsar, India

^{***}Deptt. of Applied Physics³, GND University, Amritsar, India

ABSTRACT -Wideband code division multiple Accesses is the system favored by most operators able to obtain new spectrum and to provide a global mobility with wide range of services including telephony, paging, messaging, internet and broadband data.. In WCDMA, each user transmits a data sequences spread by a code commonly called spreading code. This code is Unique to the mobile station (MS) to base station (BS) connection on both uplink and downlink. This paper deals with analytical treatment and computer aided performance analysis of downlink FDD mode of WCDMA under the variable strategic conditions of processing gain, signal to noise as well as number of interference at 10 MHz bandwidth.

1. INTRODUCTION

Emerging requirements for higher rate data services and better spectrum efficiency are the drivers for the third generation mobile radio system. ITU third generation network (IMT 2000) and Europe (UMTS) have proposed main objectives for the third generation as follows:

- Full coverage and mobility for 144 Kbps, Preferably 384 Kbps,
- Limited coverage and mobility for 2 Mbps,
- High spectrum efficiency compared to existing system.
- High flexibility to introduce new services

WCDMA has an edge over the existing techniques in terms of capacity, voice quality, coverage area, power requirement, security and bandwidth etc. Algorithm for computer aided simulation has been developed. The study is useful in the Link level simulation of WCDMA for mobile communication. Computer Aided system level simulation of WCDMA FDD mode has been attempted which is useful in the following Scenario.

- In order to increase the accuracy and performance of WCDMA network Capacity.
- In the planning of WCDMA network.
- To achieve the flexibility in use data rates in different environment.
- In the reduction of multiple Access Interference (MAI) which is the dominate factor in system capacity and quality of communication at minimum power level.
- Better use of available radio frequency bandwidth.
- Design of future Cellular Mobile Communication Network.

- Useful to enhance voice quality, Coverage area, Security etc.

Wideband CDMA is designed to flexibly offer support for higher bit rates, higher spectrum efficiency, higher quality of services wideband services, such as wireless Internet services (i.e. peak rate of 384 kb/s to download information web) and video transmission (data rate up to 2Mb/s). Wideband is essential about the data rate [1]. The physical limitations and impairments to radio channels such as bandwidth constraints, multipath fading, noise and interference present fundamental technical challenges to the goal of reliable high data rate communications [2].

In WCDMA system, the access scheme is Direct Sequence Code Division Multiple Access (DS-SS). The Direct Spectrum is the most commonly used technique among the different Spectrum techniques. In this technique the transmission system that combines the sending data signals with Pseudo-noise code (PN code), independent of the information data is employed as a modulation waveform to spread the signal energy over a bandwidth much higher than the signal information bandwidth (10 MHz). At the receiver the signal is despread using a synchronized replica of the PN code. FDD WCDMA uses spreading factors 4 - 512 to spread the base band data over ~5MHz band [3,4]. Figure 1,2 shows the spreading process and spreaded waveform for WCDMA at bandwidth 5 MHz. Transmitter converts an incoming data (bit) stream into a symbol stream where each symbol represents a group of one or more bits This technique is reliable and highly resistance to interference and give the opportunity to multiple users can communicate through one channel [5].

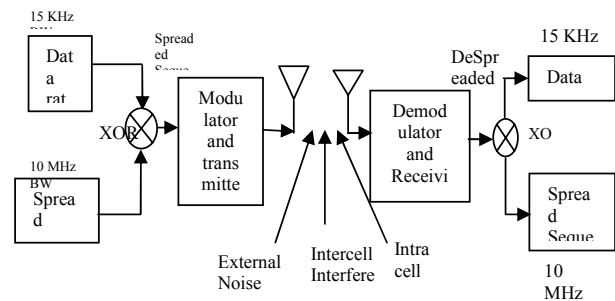

FIG.1 SPREADING PROCESS

There are two different modes of operation namely:-

- Frequency Division Duplex (FDD): - The uplink and downlink transmission employ two separated frequency bands for this duplex method (transmitter/receiving). A pair of frequency bands with specified separation for a connection.
- Time Division Duplex (TDD):- uplink and downlink transmissions are carried over the same frequency band by using synchronized time intervals thus time slots in a physical channel are divided into transmission and reception part.[6]

2. SYSTEM MODEL

In Cellular Mobile Communication systems, base station transmit signal to all the users present in a cell independently, since their relative time delays are randomly distributed. K independent user uses the same carrier frequency and may transmit simultaneously [7-10]. The kth binary source generates a binary sequence $b_k(m)$, where m is the time instant. The spreaded data is given by $X_k(t)$.

$$X_k(t) = \sum_{m=-M}^M \sqrt{E_{ck}} b_{kI}(m) C_{kI}(t-mT-\tau_k) + j \sqrt{E_{ck}} b_{kQ}(m) C_{kQ}(t-mT-\tau_k) \quad (1)$$

E_{ck} = Kth transmitted energy per chip.
 T_k = Time shift of the Kth User.
 C_{kI} = Pseudorandom Code Sequence of I channel
 C_{kQ} = Pseudorandom Code Sequence of Q channel.
 In an asynchronous system, transmitted signals have different time shift but the symbol interval (T) for the transmitters are assumed to be equal and C_{kI} , C_{kQ} is the PN codes assigned to I and Q channel. Suppose the data at the I channel is represented by the signal $d_I(t)$, while the data at Q channel is $d_Q(t)$ in eqn 1,

$$C_I(t) = C_{kI}(t - mT - \tau_k)$$

$$C_Q(t) = C_{kQ}(t - mT - \tau_k)$$

$$d_I(t) = \sqrt{E_{ck}} b_{kI}(m)$$

$$d_Q(t) = \sqrt{E_{ck}} b_{kQ}(m)$$

The figure 2 shows the transmitter and signals at different points

$$X_k(t) = d_I(t)C_I(t) + jd_Q(t)C_Q(t). \quad (2)$$

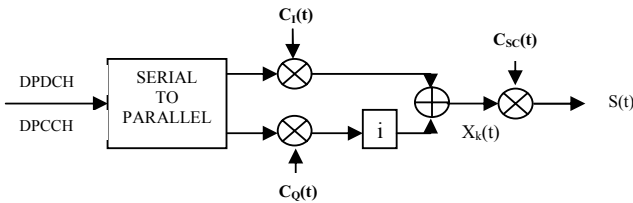

Fig.2 Signal Transmitter

The spreaded data is than coded with complex downlink scrambling code.

$$S_k(t) = X_k(t).C_{sc}(t) \quad (3)$$

where C_{sc} is the complex Downlink scrambling code.

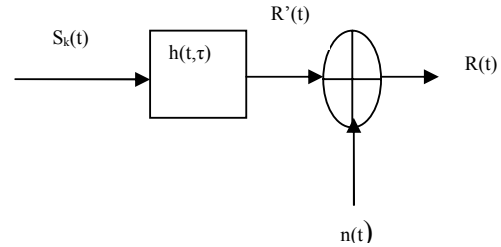

Figure 3 Transmission through Channel and Reception at the Rake Front End

Each transmitted signal is passed through a multipath channel [11]. The channel is modeled by the zero mean Additive White Gaussian Noise (AWGN) $n(t)$ with variance σ_n^2 , and there is no other distortion in the channel apart from constant linear scaling of signal amplitudes and multiple access interference caused by the presence of other active users as shown in fig 3. $R(t)$ is the received signal, $h(t, \tau_k)$ is the complex channel response due to multipath, $n(t)$ is the complex Gaussian noise at the front end of the receiver, than

$$R'(t) = \sum_{k=1}^K h(t, \tau_k) S_k(t - \tau_k) A_k \quad (4)$$

A_k is the attenuation of the kth signal, due to propagation; we assume that we have N multipath component in the channel. Each of these $h_i(t, \tau_k)$ is complex i.e.

$$h_i(t) = |h_i(t, \tau_k)| \cdot e^{j\phi_i(t, \tau_k)}$$

The received signal is given by,

$$R(t) = R'(t) + n(t)$$

The figure 4 represents the signals at the i th finger of the rake receiver. τ_k is the time shift of the kth user.

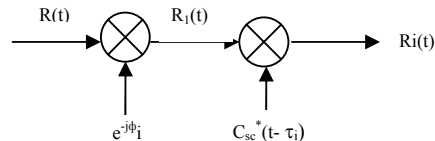

fig.4 Descrambling at Rake finger

$$R_1(t) = R(t) e^{-j\Phi_i(t)}$$

$$= \{R'(t) + n(t)\} e^{-j\Phi_i(t)}$$

$$= R'(t) e^{-j\Phi_i(t)} + n(t) e^{-j\Phi_i(t)}$$

Suppose $n_i'(t) = n(t) e^{-j\Phi_i(t)}$

$$R_1(t) = R'(t) e^{-j\Phi_i(t)} + n_i'(t)$$

$$R_1(t) = \sum_{k=1}^K |h_i(t-\tau_k)| S(t-\tau_k) e^{j\Phi_i(t)} e^{-j\Phi_i(t)} A_k + n_i'(t) \quad (5)$$

Descrambling

$$\begin{aligned} R'_1(t) &= R_1(t) C_{sc}^*(t-\tau_k) + n_i'(t) C_{sc}^*(t-\tau_k) \\ &= \sum_{k=1}^K |h_i(t-\tau_k)| S(t-\tau_k) C_{sc}^*(t-\tau_k) A_k + n_i''(t) \\ &= \sum_{k=1}^K |h_i(t-\tau_i)| X_k(t-\tau_i) C_{sc}^*(t-\tau_i) A_k + n_i''(t) \\ R''_1(t) &= \sum_{k=1}^K |h_i(t-\tau_i)| X_k(t-\tau_i) A_k + n_i''(t) \end{aligned}$$

(6)

The receiver consists of number of rake finger for simultaneous demodulation of K user signals followed by a decision block as shown in fig 5. The out put of integrate rake finger block is sampled at the of the mth symbol interval. It is represented by

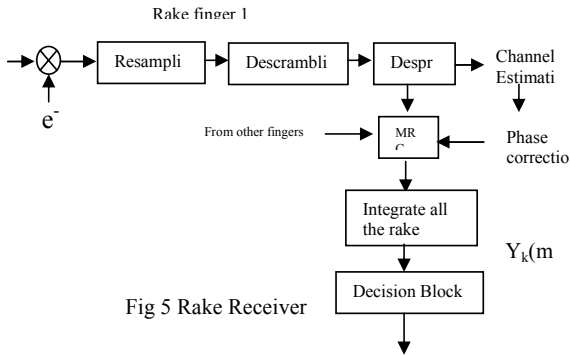

Fig 5 Rake Receiver

$$Y_k(m) = \frac{1}{T} \int_{\tau_k+mT}^{\tau_k+(m+1)T} R'_1(t) C_k(t-mT-\tau_k) dt \quad (7)$$

The final processing operation in the demodulator adds the received samples $Y_k(m)$ for all sampling instants within one bit and forms the decision variable $[Z_k(m)]$ represented as

$$Z_k = \sum_{m=1}^{G_p} Y_k(m)$$

where G_p is the number of chips per bit, which is assumed to be equal to the code sequence length (N). The kth decision device estimates the mth symbol of the kth user by examining the sign of the decision variable (Z_k). [12]

$$b_k(m) = \text{sgn}[Z_k] = \begin{cases} +1 & \text{if } Z_k \geq 0 \\ -1 & \text{if } Z_k < 0 \end{cases}$$

where m is the sampling instant, $-M \leq m \leq M$,

Substituting $R'_1(t)$ in Eqn. 7

$$Y_k(m) = \frac{1}{T} \int_{\tau_k+mT}^{\tau_k+(m+1)T} \sum_{k=1}^K h_i(t-\tau_i) X_k(t-\tau_k) A_k C_k(t-mT-\tau_k) dt + n_i''(t) \quad (8)$$

$X_k(t)$ contain the two channel parts (I & Q). But here we take only real parts at the front end of the receiver as shown in fig.6.

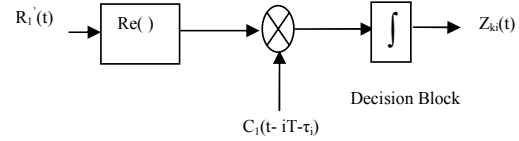

Fig 6 Despreading in Rake finger

$$Y_k(m) =$$

$$h_i(t) \sqrt{E_{ck}} b_k(m) A_k + \frac{1}{T} \int_{\tau_k+mT}^{\tau_k+(m+1)T} \sum_{i=1}^K h_i(t-\tau_i) A_i \sqrt{E_{ci}} \sum_{j=1}^M b_j(i) C_j(t-iT-\tau_j) C_k(t-mT-\tau_k) dt + n_k(m)$$

(9)

$n_k(m)$ is the Gaussian noise sample at the sampling instant m. The first term represents the desired signal, while the second term represents multiple Access interference. The Eqn 9 is further written as

$$\begin{aligned} Y_k(m) &= h_i(t) \sqrt{E_{ck}} b_k(m) A_k + \sum_{i=-M}^M \sum_{j \neq k}^K h_i(i) \sqrt{E_{ci}} A_i b_i(i) E_{ik}(l) + n_k(m) \\ E_{ik}(l) &= \frac{1}{T} \int_{\tau_k+mT}^{\tau_k+(m+1)T} C_i(t-iT-\tau_i) C_k(t-mT-\tau_k) dt \end{aligned} \quad (10)$$

$E_{ik}(l)$ is the cross correlation of code sequences in which $l = (i-m)$. The eqn 10 shows, the interference term is linear in amplitude of the interfering users.

$$Y_k(m) =$$

$$h_i(t) \sqrt{E_{ck}} b_k(m) A_k + \underbrace{\sum_{i=-M}^M h_i(i) \sqrt{E_{ci}} A_i b_i(i) E_{ik}(l)}_{\text{Interference}} + n_k(m)$$

$$Y_{k1}(m)$$

$$Y_{k2}(m)$$

$$Y_{k3}(m)$$

The first term in above equation is the desired signal $Y_{k1}(m)$. The Second term is multiple access interference

due to other user (MAI) denoted by $Y_{k2}(m)$. The last term is noise factor $Y_{k3}(m)$.

$$Y_k(m) = Y_{k1}(m) + Y_{k2}(m) + Y_{k3}(m)$$

The decision Variable, Z_k can be than represent as,

$$Z_k(t) = \sum_{m=1}^{Gp} [Y_{k1}(m) + Y_{k2}(m) + Y_{k3}(m)]$$

The average Probability of Bit Error, P_b can be expressed as

$P_b = \frac{1}{2} P_r \{ Z_k > 0, b_k = -1 \} + \frac{1}{2} P_r \{ Z_k < 0 \text{ when } b_k = +1 \}$
 Assuming that the probabilities of transmitting symbols -1 and +1 are equal. The Bit Probability can then be written as

$P_b = P_r \{ Z_k > 0, b_k = -1 \} = P_r \{ Z_k < 0 \text{ when } b_k = +1 \}$
 Assuming that the number of chips per bit, G_p is large, the decision variable Z_k can be approximated according to the Central limit theorem by a Gaussian random variable. The Bit Error probability is given by

$$P_b = Q \left[\frac{E(Z_k)}{\sqrt{\text{Var}(Z_k)}} \right]$$

$E[Z_k]$ is the mean and $\text{Var}[Z_k]$ is the variance of the decision variable Z_k . The mean value of Z_k is given by

$$E[Z_k] = E \left[\sum_{m=1}^{Gp} Y_{k1}(m) b_k = 1 + Y_{k2}(m) + Y_{k3}(m) \right]$$

$$E[Z_k] = E$$

$$\left\langle \left[\sum_{m=1}^{Gp} Y_{k1}(m) b_k = 1 + E \left[\sum_{m=1}^{Gp} Y_{k2}(m) \right] + E \left[\sum_{m=1}^{Gp} Y_{k3}(m) \right] \right] \right\rangle$$

Since

$$E \left[\sum_{m=1}^{Gp} Y_{k2}(m) \right] = 0 \quad \text{and}$$

$$E \left[\sum_{m=1}^{Gp} Y_{k3}(m) \right] = 0$$

$$E[Z_k] = E \left[\sum_{m=1}^{Gp} Y_{k1}(m) b_k = 1 \right] = Gp \sqrt{E_{ck}}$$

the variance $\text{var}(Z_k)$ is given by

$$\text{var}(Z_k) = Gp \text{var}[Y_{k1}(m)] + \text{var}[Y_{k2}(m)] + \text{var}[Y_{k3}(m)]$$

The desired signal variance is

$$\text{var}[Y_{k1}(m)] = 0$$

The variance due to thermal Gaussian noise is

$$\text{var}[Y_{k1}(m)] = N_o/2$$

Where N_o is the one sided thermal noise power spectral density. The variance of the interfering signals can be computed assuming that the interfering signal is modeled

as white noise with the two sided power spectral density of E_c/T_c . Taking into account the relative phase difference between the desired signal and interfering g signals and averaging over them.[13]

$$\text{var}[Y_{k3}(m)] \geq \sum_{\substack{i=1 \\ i \neq k}}^K \frac{E_{ck}(i)}{2}$$

Then the bit Error Probability is lower bounded by

$$P_b \geq Q \left[\frac{\sqrt{2E_{ck}Gp}}{N_o + \sum_{\substack{i=1 \\ i \neq k}}^k E_{ci}} \right]$$

The term $2E_{ck}Gp$ is the double bit energy $2E_b$ and the denominator represents the total power spectral density coming for the thermal noise and multiple access interference. If we denote by I_o , than

$$I_o = N_o + \sum_{\substack{j=1 \\ j \neq k}}^k E_{cj}$$

The bit error Probability lower bound can be written as

$$P_b \geq Q \left[\sqrt{\frac{2E_b}{I_o}} \right]$$

The bit error probability P_b on a Gaussian Channel can be approximated by

$$P_b = Q \left\{ \frac{[K-1]}{3G_p} + \frac{N_o}{2E_b} \right\}^{-\frac{1}{2}}$$

where N_o is the Gaussian noise one-sided power spectral density. This expression for the Bit Error Probability is obtained assuming Perfect power Control [14]. The degradation depends on operating E_b/N_o , the number of User (k) and the spreading factor. More users imply greater degradation, as one might expect.

5. PERFORMANCE EVALUATION

The Flow chart for Downlink FDD mode of WCDMA for computing BER was developed for computer aided performance analysis under following varying condition. The flow chart for above computation is given in Appendix 1.

Figure 7, 8 and 9 shows the variation of Bit Error Rate at different data rates, when E_b/N_o is changed from (2-10). It can be observed from the fig. 7 that system becomes interference limited. As the Number of interference is increased at the fixed value of processing gain with the bit rate is 12.2 kbps with the varying of Signal to noise ratio

(Eb/No), the required quality of service (BER) is decreased. It should be noted that the processing gain of the desired user remains constant and all users transmit at the same power. The effective value of BER is 10^{-3} is achieved at Eb/No is 6 only when one interference with the desired user is present. But as the interference users are increased from 2 to 5 the achievable target i.e BER 10^{-3} is achieved at Eb/No is 10. The same study was carried out at different data rates 64 kbps and 144 kbps. The figure 8 & 9 clearly shows that there is degradation of Bit Error rate at fixed bandwidth 10 MHz as well as data rates of 64 kbps & 144 kbps respectively, when Eb/No changed from 2 to 5. At data rate 12.2 kbps, more energy is required to get the achievable target. The other users are not aligned in time therefore the code do not align in an orthogonality way that is retain in the receiver. So these users causes the multiple access interference to be non-zero and the performance of the system is deteriorates as the number of users is increased.

CONCLUSION

In this Paper the performance of the FDD downlink of WCDMA is analyzed in term of BER and Number of interference with desired user in the varying conditions for the WCDMA system. With a wideband signal, the different propagation path of a wireless radio signal can be resolved at higher accuracy than with signals at a lower bandwidth. This result in higher diversity content against fading and thus improves the performance. In WCDMA interface different users can simultaneously transmit at different data rates and data rates can vary in time. The processing gain, together with the wideband nature, suggests a frequency reuse between different cells of a wireless system (i.e. a frequency is reused in every cell/sector). This feature can be used to obtain high spectral efficiency.

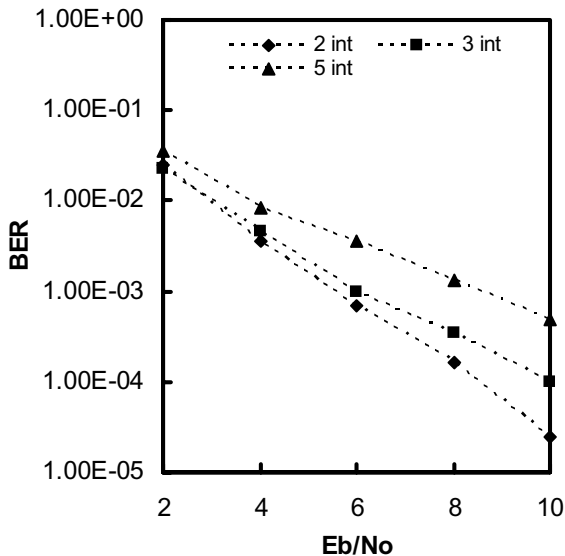

Fig.7. BER Vs Eb/No at 10 Mhz bandwidth with 12.2 kbps Bit rate, variation of interference from 2 to 5

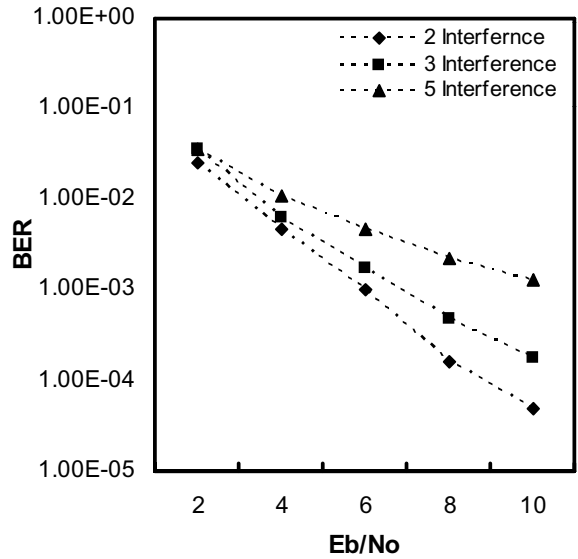

Fig.8. BER Vs Eb/No at 10 Mhz bandwidth with 64 kbps Bit rate, variation of interference from 2 to 5

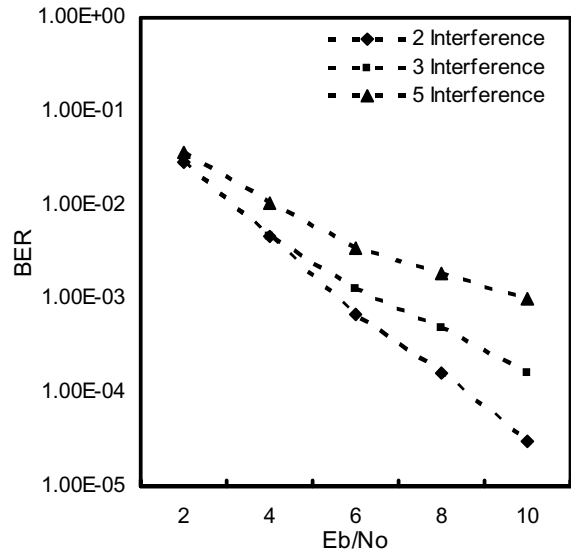
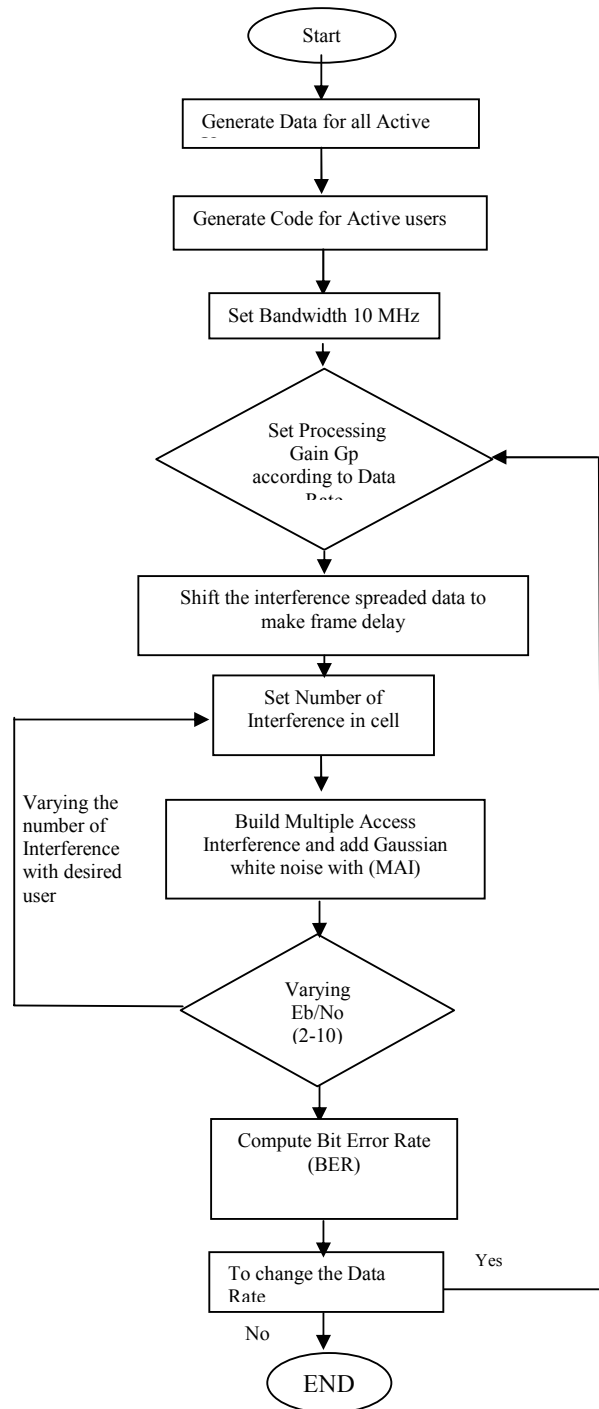

Fig.9. BER Vs Eb/No at 10 Mhz bandwidth with 144 kbps Bit rate, variation of interference from 2 to 5.

REFERENCES:

1. Dungan, R Frank, " Electronic Communication " Third Edition, Dalmar Publishers, London.
2. C.yung, Samuel " CDMA RF SYSTEM ENGINEERING " Artech House, Boston.
3. Prasad, Ramjee "CDMA FOR WIRELESS PERSONAL COMMUNICATION". Artech House ,New York.
4. Prasad Ramjee,Tero Ojenpera,"Wideband CDMA for third generation Mobile Communication", Artech House, Boston London.
5. UMTS – 3G WCDMA link budget.htm.
6. Shanmugan, K. Sam, "Digital and Analog Communication Systems", John Willey & Sons, USA.
7. Third Generation Partnership Project Technical Specification Group Radio access Network Working Group 1, "Multiplexing and Channel Coding (FDD)," TS 25.212 V2.0.1 (1999-08).
8. Lee, Edward A, Messer Schmitt, David, G "Digital Communication" Kluwer Publisher, Boston.
9. Third Generation Partnership Project Technical Specification Group Radio Access Network Group 1," Spreading and Modulation," TS 25. 213V2.1.2 (1999-4).
10. Sarkar, N . " Digital Communication ", Khanna Publication, New Delhi.
11. Vijay K. Garg, Kenneth F. Smolik & Joseph E. Wilkes, "Application of CDMA in Wireless/Personal Communications", Prentice Hall PTR, NJ.
12. Third Generation Partnership Project Technical Specification Group Radio Access Network Working Group 1, "Physical Channels and Mapping of transport Channels on to physical Channels (FDD)," TS 25.211 V 2.2.1 (1999-08).
13. Savo Glisic, "Spread Spectrum CDMA Systems for Wireless Communications", Artech House, Inc, Norwood, MA 1997.
14. S. Haykin and M. Mohar, "Modern Wireless Communications", Pearson Education New Delhi, 2005.
15. Lee.W.C.Y "Overview of cellular CDMA," IEEE Transaction on vehicular Technology, VOL. 40. May 1991,pp.291-302.
16. Journal of selected Area of Communication, vol. 18, No. 8 August 2000.



Appendix- 1 Computational flow chart of BER with Number of interference in cell for performance Evaluation