

2-IV C2

MEASUREMENTS OF NOISE DUE TO MULTI-PATH PROPAGATION ON OVERSEA LINE-OF-SIGHT PATH

Hideo Makino, Osamu Sasaki, and Tadashi Amekura

Musashino Electrical Communication Laboratory,
Nippon Telegraph and Telephone Public Corporation,
3-9-11, Musashino-city, Tokyo, Japan

Introduction

There is a growing tendency to develop microwave links over the sea due to the fact radio-relay systems over the land are congested. The reflected wave from the sea surface always exists on the oversea path and it tends to play a destructive role on the communication reliability especially for the system with large transmission capacity. To evaluate the characteristics of them, synthetic measurements on a 37.2 km oversea path were carried out in summer, 1970 and in winter, 1971, between Oshima, transmitting site with antenna height of 190 meters, and Shimoda, receiving site with antenna height of 30 meters.

The results described in this paper are concerned with the statistical properties of the thermal noise and the echo distortion noise generated in the 4 GHz 2700 telephone channels.

Measurement Technique

For the measurement of noise power, we used the noise loading method corresponding to 2700 telephone channels at the frequency of 4150 MHz. The thermal noise plus distortion noise, $N+D$, and the thermal noise, N , were separately measured by the following method.

The radio signal is frequency-modulated by random noise which extends between 12.388 MHz and 316 KHz, and is flat except for a narrow substantially noise free gap located at the specified position. The modulation is kept on and off alternatively for the period of 0.5

second by a mechanical current chopper. That is to say, for the modulated period the thermal plus distortion noise appears and for the non-modulated period, only the thermal noise appears at the receiving end. These received signals are detected with the square detection and these output are sampled and held until the next sampling period.

Thus, the noise power generated at the top channel frequency of 12150 KHz in the baseband was recorded continuously through the whole test period. The distortion noise, D , can be obtained by reducing N from $N+D$ by the use of differential amplifier, and three kind of noise, namely N , $N+D$, and D were recorded on a multi-channel recorder. This measurement system is shown in Figure 1.

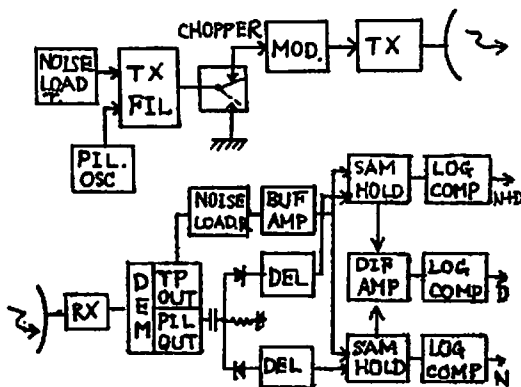

Fig.1 Block Diagram of Measuring Equipment.

Results

The excessive noise power was generated corresponding to the occurrence of medium or deep fading. In the summer test, N+D generated for about 66 hours and time percentage of that was about 7 per cent for the whole test period of about 40 days. The cumulative distribution of time duration for generating the total noise N+D can be approximated by the log-normal distribution and its median value was about 4.2 minutes. On the other hand, for the second propagation test in winter, time percentage of the excessive noise was about 1 per cent and was smaller than that of summer. It seems to be attributable to the seasonal characteristics.

The cumulative distributions of the instantaneous noise power in August regarded as the worst month in a year from the investigation of radio meteorology are shown in Figure 2. From this figure it can be seen that time percentage for which noise power exceeds 10^6 pW is about 0.0053 per cent for N+D, and is about 0.0006 per cent for N. For the whole test period in summer, the peak value of N+D was more than -25 dBm (i.e. 3×10^6 pW).

Next, the hourly mean power of N+D and N were calculated from the cumulative distribution of each hourly instantaneous noise power. The maximum hourly mean value of N+D in August was about 6300 pW and that of N was about 3500 pW. However, the periods for which N+D and N were maximum did not always coincide, for example, the power of N was only about 1000 pW when the power of N+D was maximum. The cumulative distributions of the instantaneous noise power for the worst one hour are shown in Figure 3. From this figure, it has been made clear that the echo distortion noise due to multi-path propagation is more dominant than the thermal noise. For this period, antenna height patterns measured at a frequency of 6.7 GHz were very irregular. This shows that the

propagation mechanism under this condition may be interpreted as occurrence of multi-rays due to radio ducts in addition to the direct and the sea-reflected waves.

Referring the C.C.I.R. transmission objective to this hop by the proportionarity to distance, the time percentage of excessive noise power is about 1.5×10^{-4} per cent and the mean power of noise for the worst one hour is about 111.6 pW. On the other hand, these values obtained by the actual measurement in this hop are 5×10^{-3} per cent and 6300 pW respectively. From the above mentioned results, it is concluded that some methods such as space diversity reception should be applied to reduce noise power. Such a test will be carried out in autumn, 1971.

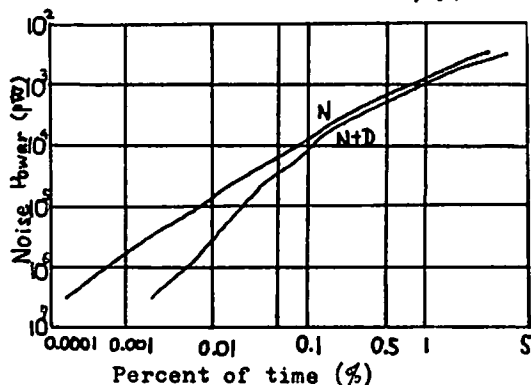

Fig.2 The cumulative distributions of instantaneous noise power in August.

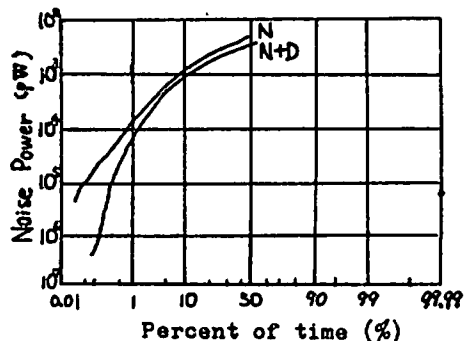

Fig.3 The cumulative distributions of instantaneous noise power for the worst one hour.