

Antenna Technology for Medical Applications

#Koichi ITO⁽¹⁾

(1) Faculty of Engineering, Chiba University
1-33 Yayoi-cho, Inage-ku, Chiba, 263-8522, Japan
E-mail: ito.koichi@faculty.chiba-u.jp

Abstract

Various types of medical applications of antennas have widely been investigated. In particular, hyperthermia is one of thermal therapies and is a modality for cancer treatment utilizing the difference of thermal sensitivity between tumor and normal tissue. The author *et. al.* have developed a coaxial-slot antenna, which is one of thin microwave antennas to be employed for interstitial as well as intracavitary microwave hyperthermia. In this paper, two different types of coaxial-slot antennas are introduced for the treatment of brain tumor and bile duct carcinoma. Then calculated results of thermal patterns around the antennas are described.

1. INTRODUCTION

In recent years, various types of medical applications of antennas have widely been investigated and reported [1]. Such typical applications are listed as follows:

- 1) Treatment (Thermal therapies)
 - Microwave hyperthermia (See Fig. 1)
 - Microwave coagulation therapy
- 2) Diagnosis
 - MRI / fMRI (See Fig. 2)
 - Microwave CT / radiometry
- 3) Information transmission
 - Telemedicine
 - Wireless capsule endoscopy

In particular, minimally invasive microwave thermal therapies using thin coaxial antennas are of a great interest. They are interstitial microwave hyperthermia [2] and microwave coagulation therapy (MCT) [3] for medical treatment of cancer, cardiac catheter ablation for ventricular arrhythmia treatment [4], thermal treatment of BPH (Benign Prostatic Hypertrophy) [5], etc. Until now, the author *et. al.* have been studying several applicators for microwave hyperthermia.

Hyperthermia is one of the modalities for cancer treatment, utilizing the difference of thermal sensitivity between tumor and normal tissue. In this treatment, the tumor is heated up to the therapeutic temperature between 42 and 45 °C without overheating the surrounding normal tissues. We can enhance the treatment effect of other cancer treatments such as radiotherapy and chemotherapy with hyperthermia.

There are a few methods for heating cancer cells inside the human body. Especially, the author *et. al.* have been studying the coaxial-slot antenna [6], which is one of thin microwave antennas for microwave hyperthermia. Coaxial-slot antennas can be employed for interstitial and intracavitary microwave hyperthermia.

The author *et. al.* have experienced several cases of actual treatments of interstitial microwave hyperthermia for neck tumors by use of the coaxial-slot antennas and have confirmed their effectiveness [7]. Fig. 3 shows one of the actual treatments for neck tumor. In this treatment, an array applicator composed of four coaxial-slot antennas was used.

In this paper, the investigations of the coaxial-slot antenna for interstitial microwave hyperthermia aiming at the treatment of brain tumors and preliminary studies of the antenna for intracavitary microwave hyperthermia aiming at the treatment of bile duct carcinoma are described.

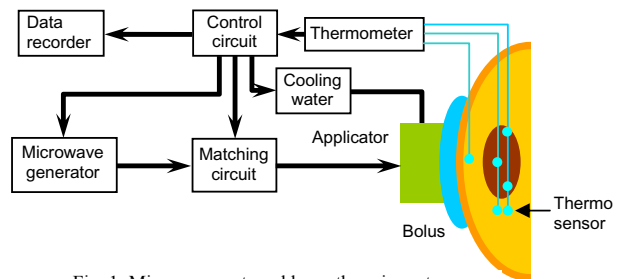

Fig. 1: Microwave external hyperthermia system

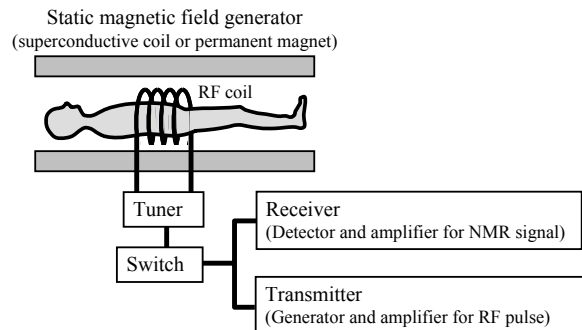

Fig. 2: Block diagram of MRI system

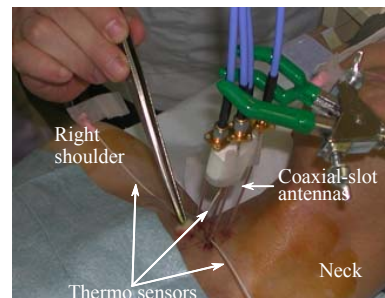

Fig. 3: Photograph of a patient during the treatment

2. COAXIAL-SLOT ANTENNA FOR INTERSTITIAL MICROWAVE HYPERTHERMIA

Fig. 4 shows the structure of the coaxial-slot antenna operating at 2.45 GHz. The antenna is composed of a thin semi-rigid coaxial cable. Some ring slots are cut on the outer conductor of the cable and the tip of the cable is short-circuited. Here, L_{ts} is the length from the tip to the center of the slot close to the feeding point, and L_{ls} is the length from the tip to the center of the slot close to the tip. We previously confirmed the possibility of generating a localized heating pattern by employing two slots, especially when L_{ts} and L_{ls} are set to 20 mm and 10 mm, respectively. In addition, we also confirmed that the heating pattern of this coaxial-slot antenna is independent of the antenna insertion depth [7].

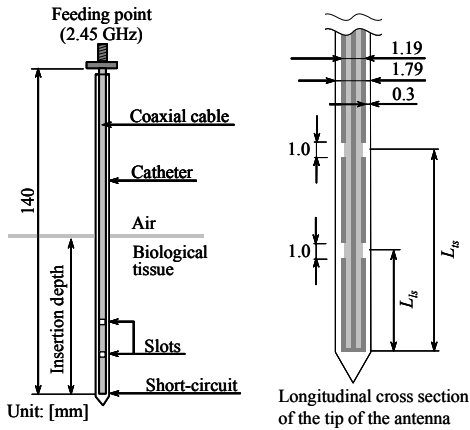

Fig. 4: Structure of the coaxial-slot antenna

Fig. 5 shows the procedure of numerical calculation. In the calculation, first, we analyze the electric field around the antenna by the FDTD (Finite Difference Time Domain) method and calculate the SAR (Specific Absorption Rate) from the following equation:

$$\text{SAR} = \frac{\sigma}{\rho} E^2 \quad [\text{W/kg}] \quad (1)$$

where σ is the conductivity of the tissue [S/m], ρ is the density of the tissue [kg/m^3], and E is the electric field (rms) [V/m]. The SAR takes a value proportional to the square of the electric field generated around the antennas and is equivalent to the heating source created by the electric field in the tissue. The SAR distribution is one of the most important antenna characteristics for heating.

Next, we calculate the temperature distribution around the antenna. In order to obtain the temperature distribution in the tissue, we numerically analyze the bioheat transfer equation [8] using the FDM (Finite Difference Method). The bioheat transfer equation is given by

$$\rho c \frac{\partial T}{\partial t} = \kappa \nabla^2 T - \rho \rho_b c_b F (T - T_b) + \rho \cdot \text{SAR} \quad (2)$$

where T is the temperature [$^{\circ}\text{C}$], t is the time [s], ρ is the density [kg/m^3], c is the specific heat [J/kg·K], κ is the thermal conductivity [W/m·K], ρ_b is the density of the blood [kg/m^3], c_b is the specific heat of the blood [J/kg·K], T_b is the temperature of the blood [$^{\circ}\text{C}$], and F is the blood flow rate [$\text{m}^3/\text{kg}\cdot\text{s}$].

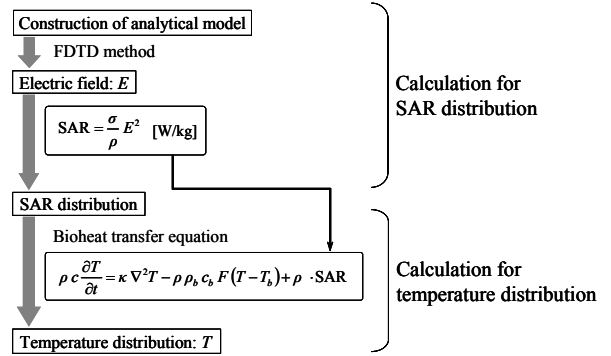

Fig. 5: Procedure of numerical calculation

Fig. 6 shows the calculation model based on the actual MR images of a patient with a brain tumor. The coaxial-slot antenna is placed almost at the center of the tumor and a region close to the antenna is picked up for the calculations. In the calculation, we employed non-uniform grids and used small-size grids only for the antenna. In addition, at the temperature calculation, we used the same grids as the FDTD calculation and calculated only inside the biological tissue (region $z > 30$ mm). Table I shows the physical (electrical and thermal) properties of some biological tissues for the calculation. Here, temperature-dependent physical properties were not considered.

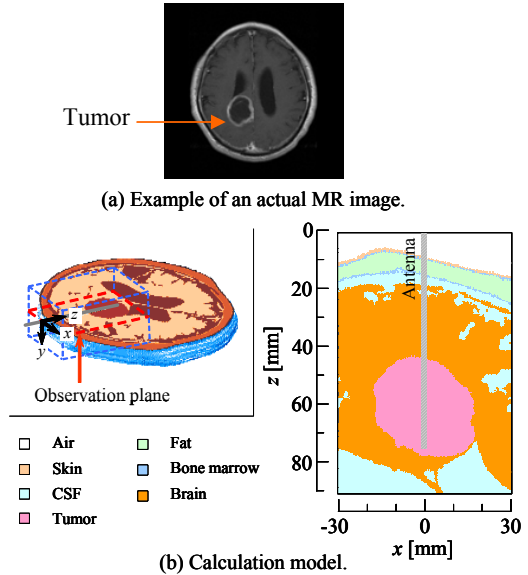

Fig. 6: Calculation model based on the actual MR images

TABLE I: PHYSICAL PROPERTIES OF BIOLOGICAL TISSUES AROUND THE BRAIN (E.G. [9])

	Tumor (center)	CSF	Gray matter	White matter
Relative permittivity ϵ_r	38.0	66.2	48.9	36.2
Conductivity σ [S/m]	1.15	3.46	1.80	1.21
Density ρ [kg/m ³]	1,040	1,007	1,038	1,038
Specific heat c [J/kg·K]	3,900	4,000	3,680	3,600
Thermal conductivity κ [W/m·K]	0.57	0.60	0.57	0.50
Blood flow rate F [m ³ /kg·s]	0.0	9.33×10^{-6}	9.33×10^{-6}	9.33×10^{-6}

The actual calculation model includes 14 media. The blood flow rate of the tumor (center) was set to 0 because a necrotic tissue was considered.

Fig. 7 shows the calculated temperature distribution in the observation plane (x - z plane at $y = 0$). Here, the net input power of the antenna (= input power – reflection power), the initial temperature, and the heating time are set as 5.0 W, 37 °C, and 600 s, respectively. From Fig. 7, we can observe a uniform heating region around the tip of the antenna. In addition, we may say that the region of the tumor is almost covered by the therapeutic temperature (42 °C or more) under the above-mentioned conditions.

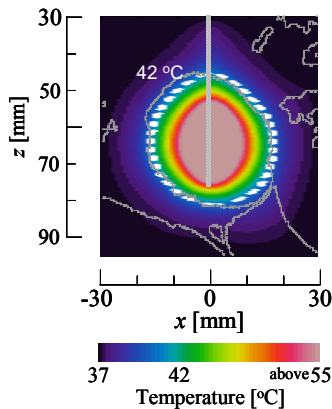

Fig. 7: Calculated temperature distribution

3. COAXIAL-SLOT ANTENNA FOR INTRACAVITARY MICROWAVE HYPERTHERMIA

A. Scheme of the treatment

There are some methods to treat the tumor inside of the body by intracavitary hyperthermia. This time, we have developed a coaxial-slot antenna aiming at intracavitary heating for bile duct carcinoma. Fig. 8 shows the scheme of the treatment. In the treatment, first, the endoscope is inserted into the duodenum and a long and flexible coaxial-slot antenna is inserted into the forceps channel of the endoscope, which is used to insert the tool for treatment. Finally, the antenna is

guided to the bile duct through the papilla of Vater, which is placed in the duodenum.

Fig. 9 shows the structure of the coaxial-slot antenna for this treatment. The basic structure of this antenna is the same as that of the Fig. 4 except that the whole structure is flexible.

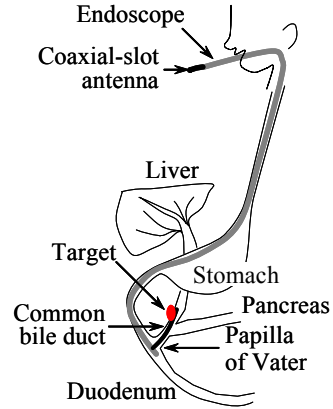

Fig. 8: Scheme of the intracavitary microwave hyperthermia for treatment of bile duct carcinoma

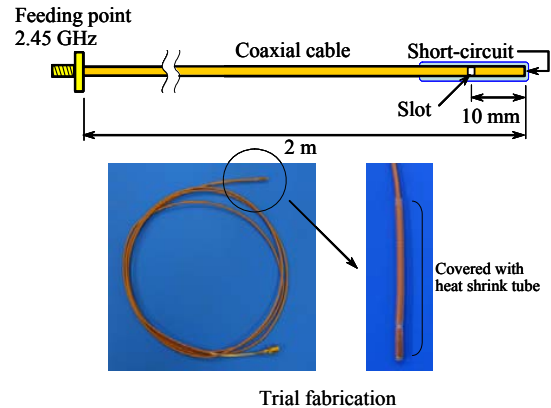

Fig. 9: Coaxial-slot antenna for intracavitary heating

B. Temperature distribution around the antenna

In order to investigate the possibility of heating the bile duct carcinoma, we calculated the temperature distribution around the tip of the antenna. Fig. 10 shows the calculation model based on the realistic human model developed at Brooks Air Force Base Laboratories [10]. In Fig. 10, only the bile duct is indicated inside the calculated region though there are a few other organs such as liver, stomach, duodenum, small intestine, etc. The procedure of the calculation is the same as in Fig. 5. However, there are two thick blood vessels (hepatic portal vein and inferior vena cava) close to the bile duct. Therefore, in the temperature calculations, the effect of cooling due to the blood flow was considered. The physical properties of the biological tissue for the calculations are set

by [9], [10]. Here, the net input power of the antenna and the heating time are 5.0 W and 600 s, respectively. Fig. 11 shows the calculated temperature distribution around the antenna. The observation plane is indicated in Fig. 10. From Fig. 11, we can observe a region, which is more than 42 °C. As a further study, we will investigate the heating characteristics by experiments using tissue-equivalent phantoms and an actual endoscope.

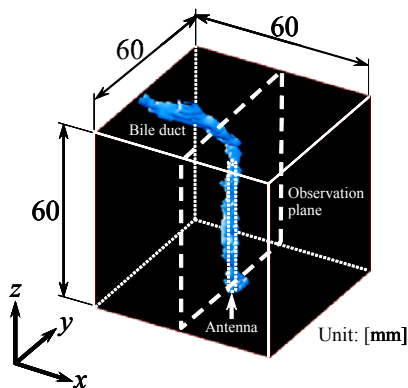

Fig. 10: Calculation model around the bile duct

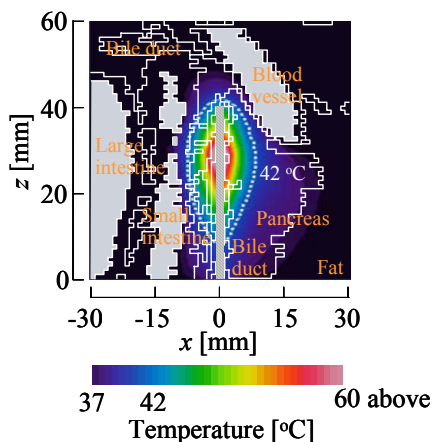

Fig. 11: Calculated temperature distribution around the bile duct

4. CONCLUSION

This paper describes the applications of the coaxial-slot antenna for the interstitial and the intracavitary microwave hyperthermia. First, we calculated the heating patterns around the coaxial-slot antenna aiming at the treatment of brain tumor. Next, the investigation of the heating performances of the coaxial-slot antenna for treatment of bile duct carcinoma was shown. As a result, the possibility of the treatment was clarified by use of the realistic human model. As a further study, we will do animal experiments to treat brain tumors and will study antennas for the intracavitary heating aiming at practical treatment.

ACKNOWLEDGEMENT

The author would like to thank Prof. Yutaka Aoyagi, Tokyo Dental College, Japan, Dr. Hideaki Takahashi, Niigata University, Japan, and Dr. Toshio Tsuyuguchi, Chiba University, Japan for their valuable comments from the clinical side.

REFERENCES

- [1] F. Sterzer, "Microwave medical devices," *IEEE Microwave Magazine*, vol. 3, no. 1, pp. 65-70, 2002.
- [2] M.H. Seegenschmiedt, P. Fessenden, and C.C. Vernon (Eds.), *Thermoradiotherapy and thermo-chemotherapy*, Berlin: Springer-Verlag, 1995.
- [3] T. Seki, M. Wakabayashi, T. Nakagawa, T. Itoh, T. Shiro, K. Kunieda, M. Sato, S. Uchiyama, and K. Inoue, "Ultrasonically guided percutaneous microwave coagulation therapy for small carcinoma," *Cancer*, vol. 74, no. 3, pp. 817-825, 1994.
- [4] R.D. Nevels, G.D. Arndt, G.W. Raffoul, J.R. Carl, and A. Pacifico, "Microwave catheter design," *IEEE Transactions on Biomedical Engineering*, vol. 45, no. 7, pp. 885-890, 1998.
- [5] D. Despretz, J.C. Camart, C. Michel, J.J. Fabre, B. Prevost, J.P. Sozanski, and M. Chivé, "Microwave prostatic hyperthermia: interest of urethral and rectal applicators combination – Theoretical study and animal experimental results," *IEEE Transactions on Microwave Theory and Techniques*, vol. 44, no. 10, pp. 1762-1768, 1996.
- [6] K. Ito, K. Ueno, M. Hyodo, and H. Kasai, "Interstitial applicator composed of coaxial ring slots for microwave hyperthermia," in *Proceedings of International Symposium on Antennas and Propagation*, pp. 253-256, 1989.
- [7] K. Saito, H. Yoshimura, K. Ito, Y. Aoyagi, and H. Horita, "Clinical trials of interstitial microwave hyperthermia by use of coaxial-slot antenna with two slots," *IEEE Transactions of Microwave Theory and Techniques*, vol. 52, no. 8, pp. 1987-1991, 2004.
- [8] H. H. Pennes, "Analysis of tissue and arterial blood temperature in the resting human forearm," *Journal of Applied Physics*, vol. 1, pp. 93-122, 1948.
- [9] C. Gabriel, "Compilation of the dielectric properties of body tissues at RF and microwave frequencies," *Brooks Air Force Technical Report AL/OE-TR-1996-0037* (<http://www.fcc.gov/fcc-bin/dielec.sh>).
- [10] Brooks Air Force Base Homepage (<http://www.brooks.af.mil/AFRL/HED/hedr/hedr.html>)