

Propagation Characteristics of FM Broadcasting Waves at the Mid Niigata Prefecture Earthquake

#Teruaki Yoshida, Shigeru Takahashi, and Masahiro Nishi

Faculty of Information Sciences, Hiroshima City University

3-4-1, Ozuka-higashi, Asa-minami-ku, Hiroshima, 731-3194, Japan, yoshida@ieee.org

1. Introduction

The article “Impending earthquakes have been sending us warning signals and people are starting to listen” was the article on the IEEE Spectrum on December 2005 [1]. Four months later, the other article “Electromagnetic observations have been shown to be either of artificial origin or artefacts of solar-terrestrial origin, with no relation to an earthquake” was published on the IEEE Spectrum on April 2006 [2]. Which do you bet? Many electromagnetic (EM) observations have been conducted to clarify the relationship between the EM phenomena and earthquakes. After Kushida reported that anomalies of FM radio waves were detected before the Hyogoken-nanbu earthquake [3], a lot of FM radio waves have been observed by the other observatories.

Recently, many claims that EM phenomena associated with earthquakes were detected have been reported [4]. Some of them were lacking scientific evidences associated with earthquake. Then, EM phenomena associated with earthquakes are now interesting theme as discussed on the articles of the IEEE Spectrum.

We started the observation of EM phenomena using FM radio tuners from 1997 [5]. On an observation in the FM broadcasting frequency band, we have to realize an accurate observation method to identify seismic phenomena from FM radio waves such as a duct propagation or reflection from the ionosphere etc. So, we developed dual frequency method [6]. More than 100 FM tuners have been continuously operated by our research team in order to detect EM phenomena associated with earthquakes. Up to now, we detected the co-seismic EM phenomena associated with the Geiyo earthquake in 2001 [7].

We had the Mid Niigata Prefecture earthquake on October 23 in 2004. Our FM tuners located at Nobeyama received the FM radio wave of 82.3 MHz broadcasted from FM Niigata radio station. They detected EM anomalies before the earthquake. The observation has been continued until now in order to clarify whether the anomalies were pre-seismic phenomena or usual tropospheric phenomena such as duct propagation. In this paper, we will describe the observation method and propagation characteristics of FM radio waves of 82.3 MHz measured for three years at Nobeyama observatory.

2. Observation Method

We had the Mid Niigata Prefecture earthquake ($M=6.8$, $d=13\text{km}$) on October 23 in 2004. Figure 1 shows a map of the epicentre, FM broadcasting station of 82.3 MHz, and Nobeyama EM observatory. The epicentre is almost between the FM station and the EM observatory. The propagation profile is shown in Figure 2. The propagation path from the FM broadcasting station to Nobeyama EM observatory is non-line-of-sight obstructed by Echigo Mountains and Mt. Asama.

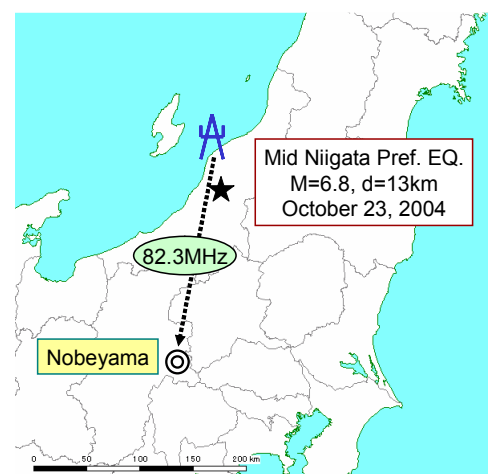

Figure 1: The Epicenter of Mid Niigata Pref. EQ., Nobeyama Obs., and FM Radio Station

Figure 3 shows our observational system at Nobeyama. Three Yagi-Uda antennas are installed on a rooftop toward Mt. Asama, Mt. Fuji, and Tokai area. Six FM tuners are connected to three antennas, so dual frequency method is available. The observation clock is adjusted by the clock of GPS. Demodulated FM audio signals are recorded into a HDD. Then, we can identify a detected signal whether an FM radio wave or artificial noise or natural noise.

Before starting observation at Nobeyama, our observation system has been eliminated against artificial noises and interferences, then, the observation system can detect the Galactic noise corresponding to culminate of the Milky Way.

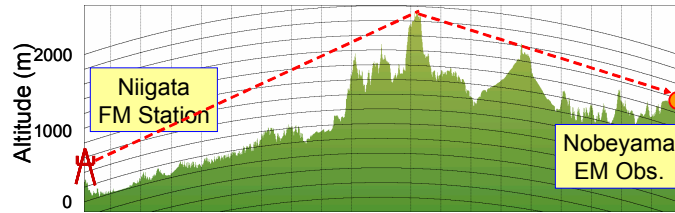

Figure 2: Propagation Path Profile

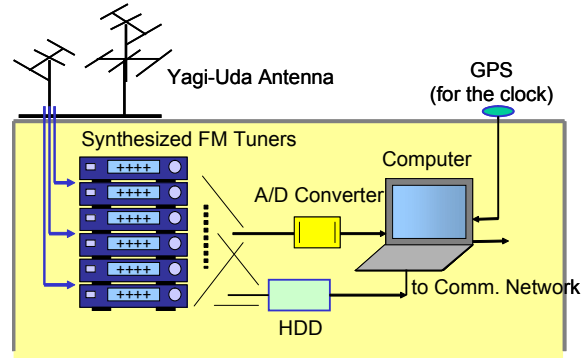

Figure 3: Observational System

3. Propagation Characteristics of FM Broadcasting Wave of 82.3MHz

The FM tuner of 82.3 MHz has been measuring the received level from FM Niigata radio station for three years. Before the observation, the FM signal of 82.3 MHz was identified as the signal from FM Niigata radio station by the FM de-modulated signal. In this chapter, the observation results are shown.

3.1 Seasonal Propagation Characteristics for three years

Figure 4 shows fluctuation level of the received wave of 82.3 MHz for each days in 2004, 2005, and 2006 respectively. Seasonal fluctuations, several dB in winter and more than 5 dB in summer, are found in it.

3.2 Propagation Characteristics on Nine Days of October for three years

We had the Mid Niigata Prefecture earthquake (M=6.8, d=13km) on October 23 in 2004. Figure 5 shows the received levels of 82.3 MHz at Nobeyama from October 17 to October 25 in 2004.

Received levels are fluctuated several dB around -110dBm on the day of the earthquake. On October 18, received levels are fluctuated up to -94dBm which might be considered as pre-seismic anomalies. Before claiming that we detected pre-seismic anomalies, our observation has been continued for three years. Because, it is well-known in the tropospheric propagation of FM radio wave that a received level is fluctuated by a temperature, humidity, a wind speed, an air pressure, etc [8]. As shown in Figure 4, seasonal fluctuations were observed. So, it should be necessary to compare the received levels in 2004 with in 2005 and in 2006.

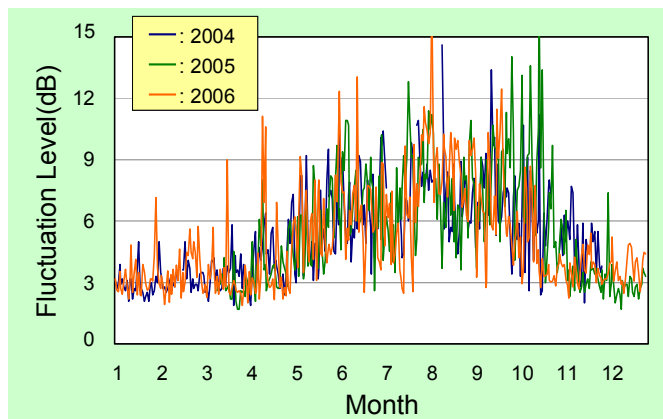

Figure 4: Seasonal Fluctuations of 82.3MHz in 2004, 2005, and 2006 at Nobeyama Obs.

Figure 6 and 7 show the received levels of 82.3 MHz at Nobeyama from October 17 to October 25 in 2005 and in 2006 respectively. Received levels shown in Figure 6 are fluctuated from -120dBm to -90dBm. Especially, the received level is increased to -90dBm in the early morning of October 19 in 2005. On the other hand, received levels shown in Figure 7 are only fluctuated about 5dB around the usual level of -110dBm. From October 17 to October 25 for three years, the maximum fluctuation was measured in 2005 and the minimum fluctuation was measured in 2006.

4. Discussions

Are there any pre-seismic anomalies at the Mid Niigata Prefecture earthquake? We have investigated the received levels during the same season for three years. Because, it is well-known in the tropospheric propagation of FM radio wave that a received level is fluctuated by a temperature, humidity, a wind speed, an air pressure, etc. The received level increased to -94dBm on October 18 in 2004. On that day, it was confirmed by meteorological data that the propagation path area was covered by a high atmospheric pressure on October 18 in 2004. Moreover, the received level were fluctuated and increased to -90dBm from October 17 to October 20 in 2005. It was also confirmed by meteorological data that the propagation path area was covered by a high atmospheric pressure on these days. These propagation results suggest that the increases of received levels are due to duct propagation. So, there might be no pre-seismic anomaly in the FM propagation data at the Mid Niigata Prefecture earthquake.

On the observation of electromagnetic phenomena associated with earthquake on FM radio propagation, it is important to take into account not only electromagnetic data but also meteorological data.

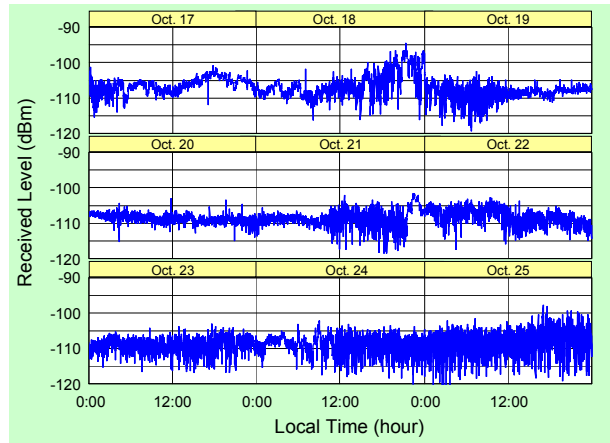

Figure 5: Received Levels of 82.3MHz at Nobeyama Obs. on October 17-25 in 2004

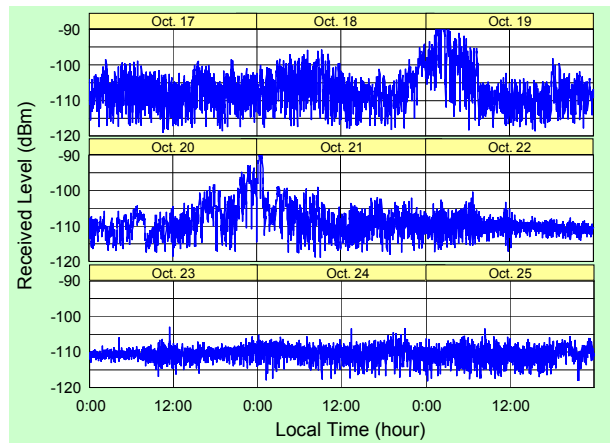

Figure 6: Received Levels of 82.3MHz at Nobeyama Obs. on October 17-25 in 2005

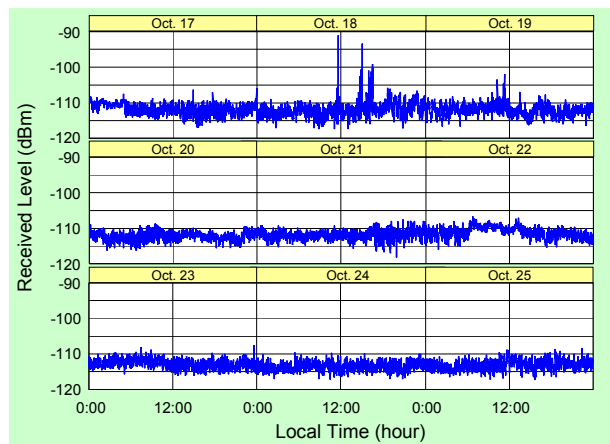

Figure 7: Received Levels of 82.3MHz at Nobeyama Obs. on October 17-25 in 2006

5. Conclusions

We have measured FM radio waves of 82.3 MHz broadcasted from FM Niigata radio station for three years at Nobeyama observatory. In this period, we had the Mid Niigata Prefecture on October 23 in 2004. The FM tuners installed at Nobeyama observatory detected EM anomalies before the earthquake. The observation has been continued in order to clarify whether the anomalies were pre-seismic phenomena or usual tropospheric phenomena such as duct propagation. They conclude that the detected fluctuations are caused by usual duct propagation.

The observation results suggest it is important to discriminate EM anomalies from those due to usual tropospheric propagation phenomena. We will continue to observe EM phenomena in FM band discriminated against a background of natural and man-made noises.

Acknowledgments

The observation data shown in this paper have been detected by kind co-operations of Nobeyama research laboratory. This observation supported by the Grant-in-aid Scientific Research (C) No. 17560346 and Hiroshima City University Grant for Special Academic Research No. 6113.

References

- [1] T. Bleier and F. Freund, "Impending earthquakes have been sending us warning signals and people are starting to listen", *IEEE Spectrum*, December, pp.17-21, 2005.
- [2] R. J. Geller, A. Braginski, and W. H. Campbell, "Electromagnetic observations have been shown to be either of artificial origin or artefacts of solar-terrestrial origin, with no relation to an earthquake", *IEEE Spectrum*, April, pp.5, 2006.
- [3] Y. Kushida and R. Kushida, "On the possibility of earthquake forecast by radio observation in the VHF band", *RIKEN Review*, No. 19, pp.1-13, 1998.
- [4] M. Hayakawa, (ed), "Atmospheric and Ionospheric Electromagnetic Phenomena Associated with Earthquakes", Terra Science Publishing Company, Tokyo, 1999.
- [5] T. Yoshida, M. Nishi, and A. Sato, "Pre-seismic Phenomena and Observations of Naturally Radiated Electromagnetic Waves in VHF", *Proc. of ISAP*, pp.525-528, 2000.
- [6] T. Yoshida, M. Nishi, and K. Mochizuki, "Observations of Seismic Electromagnetic Phenomena in VHF Band by Dual Frequency Method", *Electrical Engineering in Japan*, Vol. 115, No. 4, pp.36-44, 2006.
- [7] T. Yoshida and M. Nishi, "Observation of Co-seismic Electromagnetic Phenomena in VHF Associated with the Tottori-ken Seibu Earthquake in 2000 and the Geiyo Earthquake in 2001", *Jishin*, Vol. 55, pp.107-118, 2002.
- [8] R. L. Freeman, "Radio System Design for Telecommunications", John Wiley & Sons Inc., 1997.