

# A Design Method for an Antenna Radiating in a Fluid Liquid

Akihiro TSUJIMURA Syuichi SEKINE Hiroki SHOKI Yasuo SUZUKI  
Kazuhiro WATANABE\* Yuji MIYANE\*

Corporate Research & Development Center, Toshiba Corp.  
1, Komukai-Toshiba-cho, Saiwai-ku, Kawasaki 212-8582, Japan  
a-tsuji@csl.rdc.toshiba.co.jp

\*Information and Industrial Systems & Services Company, Toshiba Corp.  
1, Toshiba-cho, Fuchu-shi, Tokyo 183-8511, Japan

## **1 Introduction**

There is a need to measure, using an electromagnetic wave, the material constant of liquid flowing at high speed inside a metal pipe. An electromagnetic wave is radiated from the antenna through a dielectric window constructed of the wall of a pipe. A design of such an antenna is difficult because the high powerful calculation by the finite-difference time-domain (FDTD) method [1] is needed.

The purpose of this paper is to propose the design method, which cuts down the process of the design. And also, we will confirm the applicability of this design method. The proposed method takes two steps. In the first step, a dielectric window is designed by the transmission line model approximation. In the second steps, the antenna block is designed by the FDTD method including the window model, which is designed in the first step.

## **2 Antenna configuration**

The configuration of the proposed antenna is shown in Fig.1. This antenna is composed of the dielectric window and the antenna block. It is surrounded by metal except for the side contiguous with the liquid.

In this paper, the structure etc. of the dielectric window is designed by restricted conditions for considering the real antenna.

At first, the designing frequency is set 2GHz. The structure of the dielectric window is selected a cylindrical type so that manufacturing of the portion becomes easy. The radius of the dielectric window is a little larger than the cutoff of TE<sub>11</sub> mode. If the radius is too large, the dielectric window becomes weak mechanically.

The convex part of dielectric window is arranged at the center of the window for fixing to the pipe.

The material of the dielectric window is the relative permittivity 15 or less because the window becomes strong mechanically to protect from the power of the liquid flowing.

The material of the antenna block is the relative permittivity 10 so that the trimming of the antenna structure becomes easy for tuning.

### **3 Method for Designing Antenna**

A design of the antenna on fig. 1 needs time consuming because the high powerful calculation by the finite-difference time-domain (FDTD) method is required. The proposed method takes two steps for cutting down the process of the design.

In the first step, a dielectric window is designed by the transmission line model approximation; that is, this step decides the initial value of the model for the FDTD method in the next step. It results that the first step reduces the parameter for optimizing and the time for calculation of the FDTD method.

The distributed constant circuit model used in the first step is shown in Fig.2. This model is approximated to the dielectric window constructed by three circular waveguides.

In order to realize the small size antenna, transverse electric wave is assumed to be the only fundamental mode (TE<sub>11</sub>) in the dielectric window. The optimum value of the thickness  $d_1$ - $d_3$  and the radius  $r_1$ - $r_3$  are determined to realize good matching between the impedance  $Z_3$  and the characteristic impedance of water at 2GHz.

We employed two cases; model 1 is tuned to match water well, and model 2 is tuned to mismatch for comparison. In the case of model 1, the return loss is -26dB.

### **4 Analytical models**

In the second step, the FDTD algorithm based on Yee's cell is applied to clarify the characteristics of the antennas shown in Fig.1. The region for FDTD is partitioned into 60x60x60 cells. The cell size is chosen  $D_x=D_y=D_z=1.0$ mm. At the edge of the space, Mur's absorbing boundary condition [2] is applied. In order to ensure stability, the time increment is chosen  $Dt=1.2$  picosecond.

The antenna block is shown in Fig.3. The feed point of the antenna element is F, as shown in Fig.3, and this point is the reference plane for input impedance. Inverted-L antenna is formed on substrate thickness of 8mm. The length of the antenna is 23mm.

The parameters of the analytical models are shown in the table. In each case, the liquid assumes the water. The water has the relative permittivity of 80.

### **5 Numerical results**

The input impedance and the pointing vector were calculated for each of the two models. And the designed resonant frequency is 2GHz.

Figures 4 and 5 show the input impedance on the Smith chart, and the calculated return loss for two models, respectively. These figures show that the antenna of model 1 matches water well, and that of model 2 mismatches.

We only optimized for the matching of the antenna of model 1, and fig. 5 shows that the bandwidth of return loss of less than -10dB is about 4%. On the other hand, the error is occurred in the resonance frequency. The calculated resonance frequency is lower than that of the designed by 8%.

Fig.6 shows pointing vector of model 1 (z-x plane). An arrow indicates the direction in which power is transmitted and the length of an arrow indicated the amount of power transmitted. Fig. 6 shows that the calculated pointing vector points in the direction of +z axis in water. It means that the electromagnetic energy is propagated through the water efficiently.

**6 Conclusion**

This paper describes the brief design method of the antenna for measuring the medium constant of the liquid. And the proposed method is evaluated by employing for designing the real model. We tune the antenna to match the liquid well only, and the antenna achieved by the bandwidth of return loss of less than -10dB is about 4%. On the other hand, the calculated resonance frequency has an error that is lower than the designed value by 8%.

In future work, we will optimize the figure of the antenna element to fit the designed resonance frequency with maintaining the good matching performance.

**References**

[1] K. S. Yee, "Numerical solution of initial boundary value problems involving Maxwell's equations in isotropic media," IEEE Trans. Ant. Prop. , 14(3), 302, 1966.  
 [2] G. Mur, "Absorbing Boundary Conditions for the Finite-Difference Approximation of the Time-Domain Electromagnetic-Field Equations," IEEE Trans., on Electromagnetic Compatibility, Vol.EMC-23, No.4, Nov., 1981.

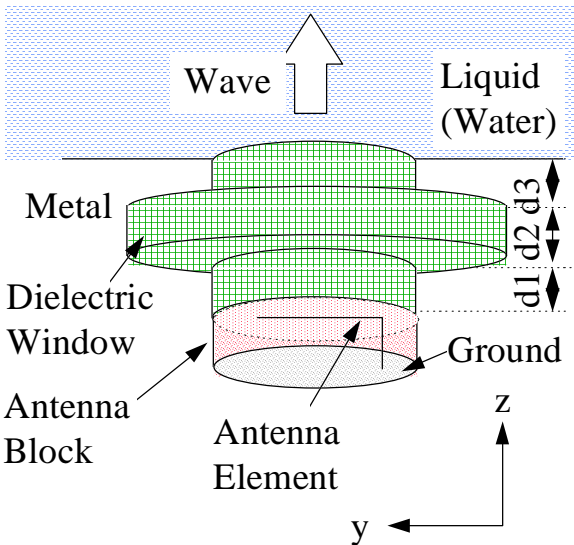

[Fig.1] Configuration of proposed antenna

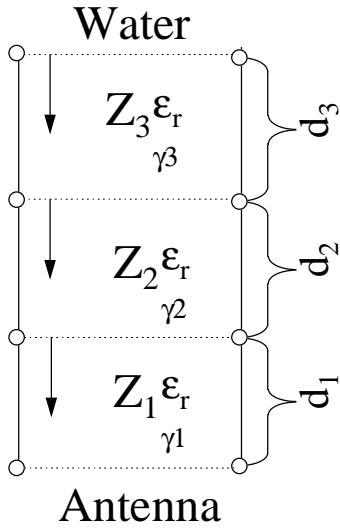

[Fig.2] Distributed constant model

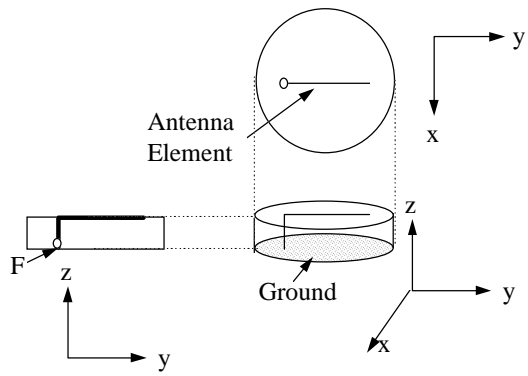

[Fig.3] Configuration of antenna block

[Table] Parameters of analytical model

	Model 1	Model 2
d1 (mm)	8	5
d2 (mm)	15	5
d3 (mm)	6	6
r1,r3 (mm)	14	
r2 (mm)	22	
$\epsilon_r(\text{window})$	15	
$\epsilon_r(\text{antenna})$	10	

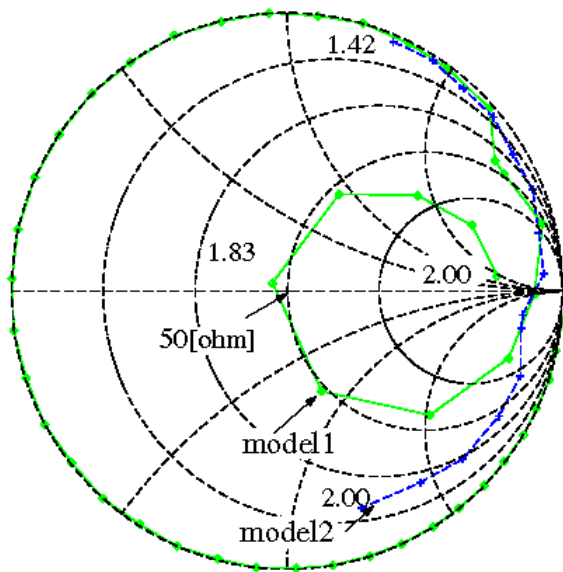

[Fig.4] Calculated input impedance

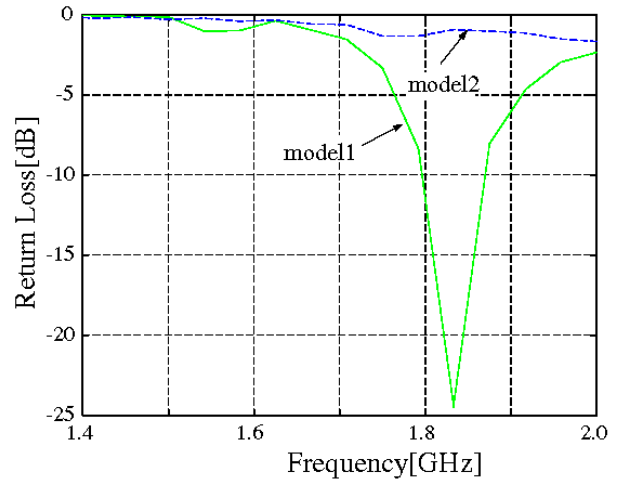

[Fig.5] Calculated return loss

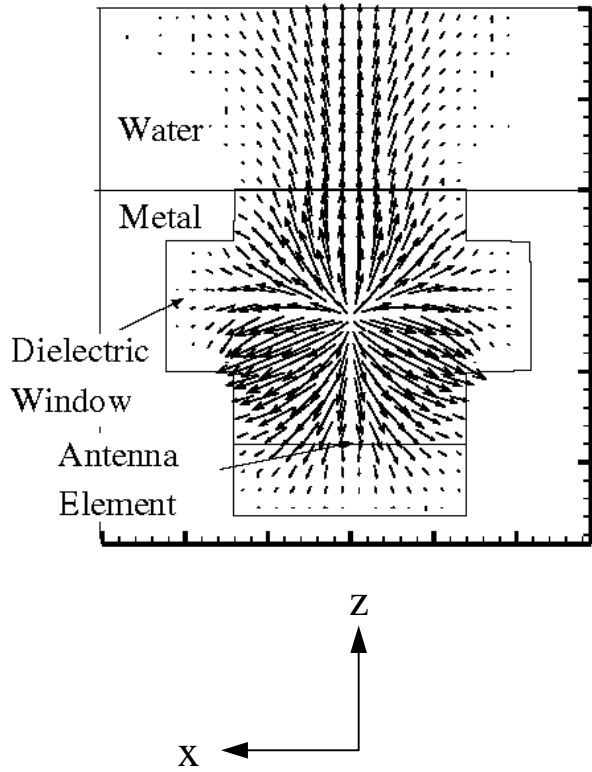

[Fig.6] Calculated pointing vector (model 1)