

EXPERIMENTAL STUDY ON FOUR-BRANCH ANTENNA PATTERN
DIVERSITY RECEPTION FOR URBAN MOBILE RADIO

Tsutomu Takeuchi, Fumio Ikegami and Susumu Yoshida
Department of Electronics, Kyoto University
Kyoto 606, Japan

1. INTRODUCTION

In order to overcome severe multipath fading encountered in urban areas, space diversity reception can be an effective remedy [1][2]. On the other hand, the authors have found that antenna pattern diversity reception (APDR) can reduce fading remarkably by the antenna pattern effects in addition to the ordinary diversity effects.

This paper describes the outline of APDR and the experimental results on improvement of fading as well as transmission bandwidth obtained by a prototype four-branch APDR with variable multi-threshold switching (VMTS) strategy.

2. PROTOTYPE APDR SYSTEM WITH VMTS

2.1 SYSTEM CONFIGURATION

A block diagram of this system is shown in Fig.1. Receiving antenna is a set of four 90°-sector antennas arranged so as to cover the whole azimuthal directions. A micro-computer executes VMTS and controls antenna switch. An additional field strength meter (FSM #2) is used in this study to measure the frequency-differential level (FDL, defined as the difference in dB between the signal strengths at two radio frequencies) which is a measure of transmission bandwidth.

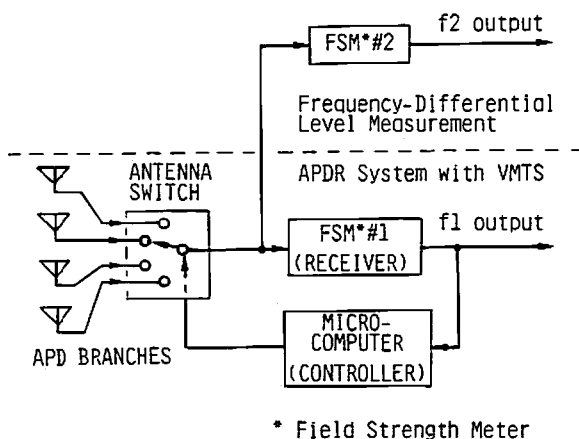

Fig.1 Block diagram of prototype APDR

2.2 FADING IMPROVEMENT EFFECTS OF DIRECTIVE ANTENNA

Precise analyses of propagation structure in urban areas revealed that ray-theoretical waves are dominant on streets [3][4]. Because of this, a directive antenna achieves three fading improvement effects, i.e. fading reduction in signal strength, gain in mean signal strength and elongation of fading period, due to separation of multipath components [5].

2.3 CORRELATION CHARACTERISTICS OF APD BRANCHES

Four diversity antennas showed the following correlation characteristics in downtown Kyoto.

- (1) Short-term fading correlation coefficients between any two of the four branches are nearly zero in average and rarely exceed 0.4.
- (2) Long-term fading also shows diversity effects. Correlation coefficients between branches are about 0.5 in average and about 0.9 at maximum.

2.4 VARIABLE MULTI-THRESHOLD SWITCHING STRATEGY

Conventional single-threshold switching diversity system loses diversity gain at low signal strengths [6], and a fixed threshold system suffers from performance degradation due to long-term fading. VMTS can overcome these disadvantages by adaptively setting multiple switching thresholds below the mean signal strength.

MTS works as follows [7]. When an instantaneous signal strength drops across a threshold, the branch in use is switched to a new branch. At the same time, the threshold is switched to a new one so that the signal strength of the new branch is just above the new threshold.

Fading improvement almost same as that of selection diversity reception is attainable with MTS using a single receiver. VMTS reduces the frequency of branch-switching as compared with the single-threshold or selection strategy.

3. FIELD TESTS

3.1 OUTLINE OF TEST

In order to confirm the performance of prototype APDR with VMTS, field tests were conducted on six streets downtown Kyoto 9 km in total length, receiving two radio channels separated by 100 kHz from each other in 400 MHz band. Multiple thresholds were chosen as shown in Fig.2, and records were made of the signal strengths at two frequencies, together with the identification of the branch in use [8].

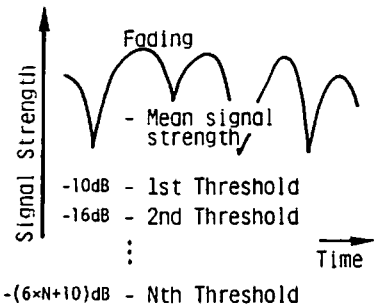
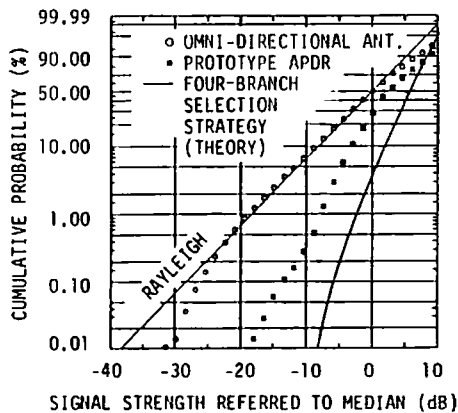
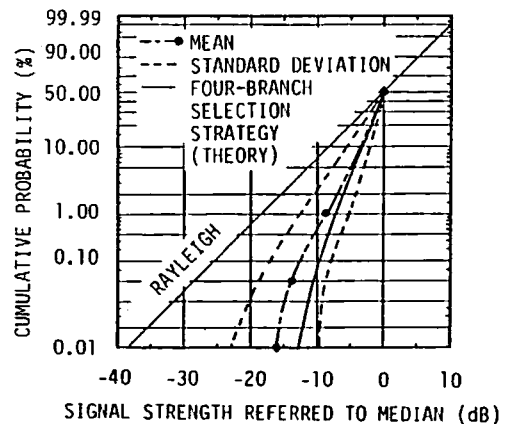

Fig.2 Threshold setting for VMTS



(a) CPD including short- and long-term fading



(b) CPD of short-term fading

Fig.3 Measured cumulative probability distribution (CPD)

3.2 TEST RESULTS

i) Fig.3 (a) shows cumulative probability distribution (CPD) including short-and long-term fading measured on Shijo street (1.5 km). Fig.3 (b) is the average and standard deviation of short-term fading (every 30 m section) CPD's over the test course, compared with the theory. From Fig.3 (b), large diversity gain for short-term fading is achieved by VMTS.

ii) Table 1 shows a mean distance between branch switching on each street. Switching frequency is reduced to one third or a quarter of that of selection strategy.

iii) Mean signal strength, fading depth (50%-90%) and mean FDL are shown in Fig.4, taken for each 10.5 m section on two representative streets, comparing with those measured by an omnidirectional antenna without diversity reception denoted by broken lines. Improvement in mean signal strength is not very much, but those in fading depth and mean FDL are marked. The improvement of

Table 1 Mean distance between branch switching in meter

NAME OF STREET	PROTOTYPE APDR	SELECTION STRATEGY
HORIKAWA	3.3	0.80
KARASUMA	1.4	0.50
KAWARAMACHI	1.2	0.35
SHIJO	1.2	0.28
OIKE	1.2	0.29
MARUTAMACHI	1.2	0.32

mean FDL is more than 1 dB in average for offset frequency of 100 kHz.

4. CONCLUSION

A prototype four-branch APDR system with VMTS has shown a good performance in field tests to improve fading and transmission bandwidth, as well as to reduce fading speed and branch-switching frequency. This system is expected to be useful for the future digital mobile communication.

ACKNOWLEDGEMENT

The authors are indebted to many students who worked on this study during their graduate courses.

REFERENCES

- [1] W.C.Y.Lee, "A Study of the Antenna Array Configuration of an M-Branch Diversity Combining Mobile Radio Receiver," IEEE Trans. on Veh. Technol., vol.VT-20, no.4, pp.93-104, Nov. 1971.
- [2] M.J.Gans, "A Power-Spectral Theory of Propagation in the Mobile Radio Environment," IEEE Trans. on Veh. Technol., vol.VT-21, no.1, pp.27-38, Feb. 1972.
- [3] F.Ikegami and S.Yoshida, "Analysis of Multipath Propagation Structure in Urban Mobile Radio Environments," IEEE Trans. on Antenna & Propag., vol.AP-28, no.4, pp.531-537, July 1980.
- [4] F.Ikegami, S.Yoshida, T.Takeuchi and M.Umehira, "Propagation factors controlling mean field strength on urban streets," *ibid.*, vol.AP-32, no.8, pp.822-829, Aug. 1984.
- [5] F.Ikegami, T.Takeuchi and S.Yoshida, "Effects of Antenna Radiation Pattern on Multipath Fading in Urban Mobile Radio," Trans. IECE Japan, vol.J68-B, no.3, pp.403-410, Mar. 1985.
- [6] F.Ikegami, S.Yoshida and T.Takeuchi, "Analysis of Fading Improvement for Switched Diversity Reception with Unequal Mean Signal Strength," *ibid.*, vol.J65-B, no.5, pp.561-568, May. 1982.
- [7] H.Kamiyama, F.Ikegami, S.Yoshida and T.Miki, "Fading Reduction of Switched Diversity Receiving System with Multi-threshold Levels," Papers of Technical Group on Antennas & Propag., TGAP 81-22, IECE Japan, June 1981 (in Japanese)
- [8] T.Takeuchi, F.Ikegami and S.Yoshida, "Frequency Correlation Characteristics of Antenna Pattern Diversity Reception in Urban Mobile Radio," Papers of Technical Group on Antennas & Propag., TGAP 84-107, IECE Japan, Jan. 1985 (in Japanese).

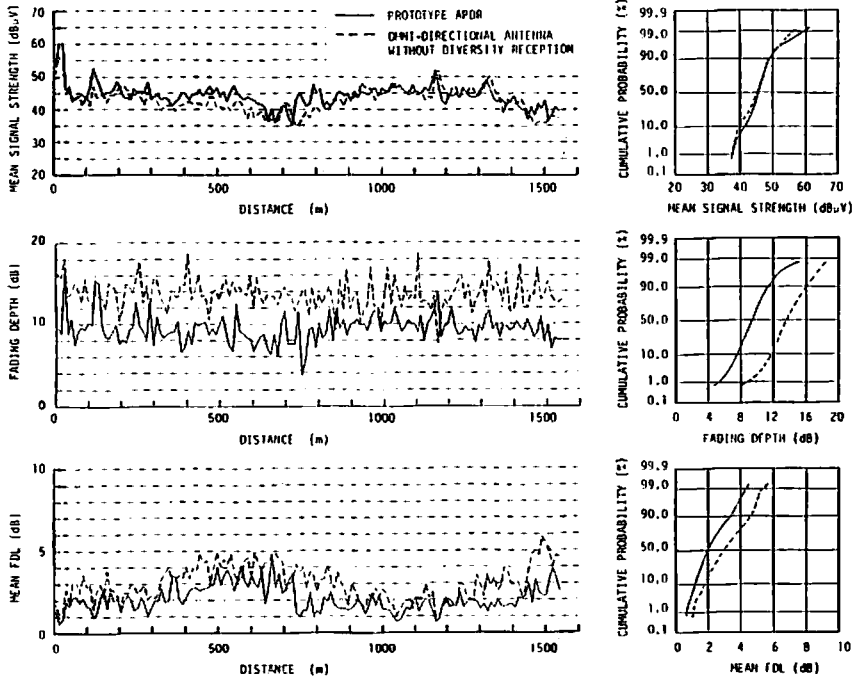

(a) Karasuma street (Street angle 10°)

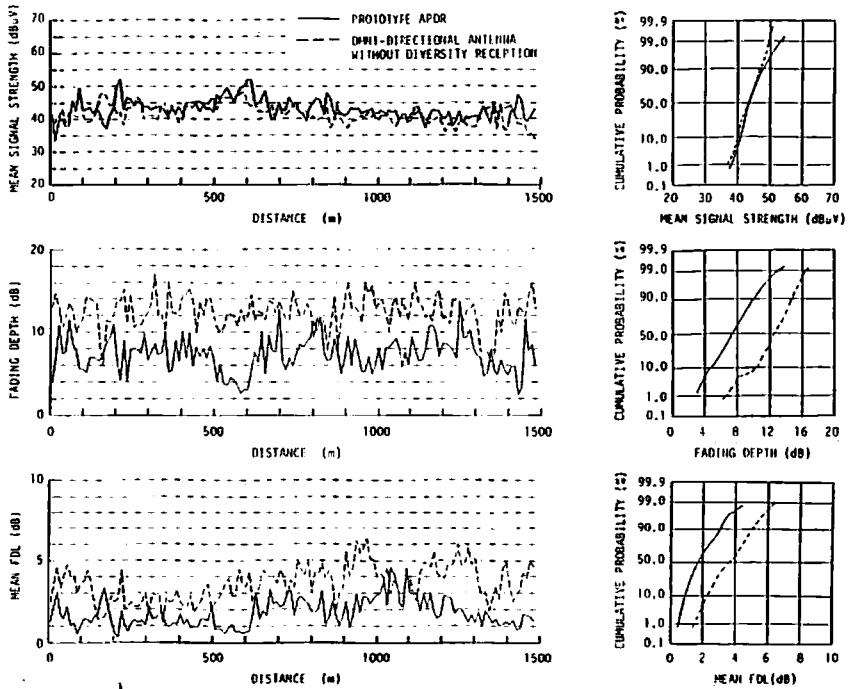

(b) Shijo street (Street angle 70°~85°)

Fig. 4 Test results of mean signal strength, fading depth and mean frequency-differential level (FDL)