

Development of the Monostatic FM-CW Radar at 95GHz

ABE Hideji¹, YOKOTE Shinichi¹, KUBO Hiroshi¹, KAWAMURA Youhei²,
TAKANO Toshiaki^{1,2,3}, KUMAGAI Hiroshi⁴, TAKAMURA Tamio⁵, NAKAJIMA Teruyuki⁶

¹Graduate School of Science and Technology, Chiba University,
Inage, Chiba 263-8522, JAPAN, takano@faculty.chiba-u.jp.

²Faculty of Engineering, Chiba University, ³Venture Business Laboratory, Chiba University,

⁴The National Institute of Information and Communications Technology,

⁵Center for Environmental Remote Sensing, Chiba University,

⁶Center for Climate System Research, The University of Tokyo

Abstract

We already developed a bistatic frequency modulated continuous wave (FM-CW) radar. And we observed clouds using the radar on a ship "MIRAI" that is a Japanese scientific research vessel, in the Arctic Ocean and the Pacific Ocean. The radar provided good and sensitive data in these long-term observations. To improve the sensitivity of the radar more, we start to develop a prototype of Monostatic FM-CW radar. The monostatic radar has advantage rather than the bistatic radar, because it doesn't have parallax, it can be realized in half of the size, and more. Therefore, it is able to use larger antenna, and to change the direction of the antenna easily. In future, it expected that the radar is able to scan the whole sky. The prototype radar is isolated between transmitting part and receiving part using a circulator. There is cancel system to cancel leakage power to receiving side from transmitting side. As a result of the initial observation, clouds and rainfall were not observed because leakage power was still strong than reflection from clouds and rainfall. By doing more alignment and improvement, it anticipates that clouds and rainfall are observed in the high-sensitivity.

1. INTRODUCTION

A part of clouds is very important for the climate variation and warming on the earth. Clouds reflect and absorb radiation from the sun and from the ground. It is kept climate balance of the earth by propagating the radiant energy. However, the influence of radiation by clouds is still not known well. To solve them, it is necessary to investigate three-dimensional structure of clouds. Therefore, observation of clouds with millimeter-wave radars is a better means [1,2]. Meteorological radar at 9GHz is developed by now, and clouds radar at 35GHz is developed, too. Then they are being operated now. But, it couldn't get necessary clouds profile with them fully. Therefore, new radar system with higher

frequency of 95GHz that has performance to observe it to the smaller cloud molecule has been developed. The clouds radar is FM-CW radar, therefore, it operated with very low output more than pulse radar which has such performance of the National Institute of Information and Communications Technology. And the radar system is made of solid state, and it has high durability. For these reasons, that has high reliability in the low cost. Using the developed FM-CW radar at 95GHz, we observed clouds in a campaign observation in Amami Island in March 2003 [3,4], and on a ship on Mirai, a Japanese scientific research vessel, in September 2004 to January 2005 in the Arctic Ocean and the southwest of the Pacific Ocean, and in September 2005 to February 2006 in the Pacific Ocean [5,6]. The radar provided good and sensitive data in these long-term observations. Besides, the durability and reliability of the radar were proved. But, because it is the bistatic antenna system, the whole size of the system is big, and we must take parallax into consideration. Therefore, it is difficult to change direction of the antenna for scan the whole sky.

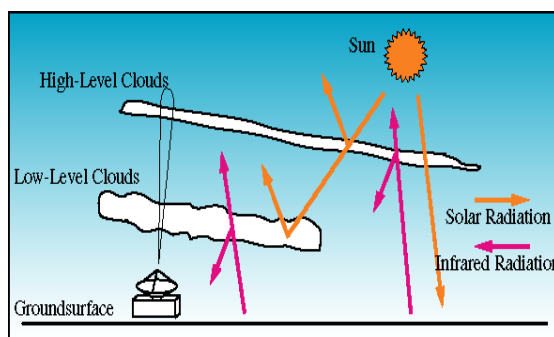

Fig.1 Influence by the clouds

To dispel these problems, we started to develop the monostatic FM-CW clouds radar at 95GHz. This radar is not just as clouds radar, and it is expected use in the multipurpose as the meteorological radar and so on.

2. FM-CW RADAR

We adopt a frequency-modulated continuous wave (FM-CW) radar rather than a pulse radar, because the sensitivity be realized with the very lower output more than the latter, and it can be composed only of the solid-state. Therefore, the radar system is compact and low cost.

The principle of an FM-CW radar is shown Fig.2.

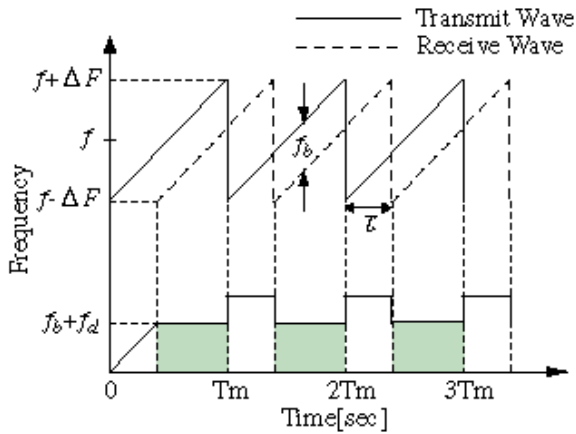

f : Center Frequency ΔF : Frequency Sweep Width
 T_m : Modulation Interval f_b : Beat Frequency
 f_d : Doppler Frequency ($f_b \gg f_d$) τ : Delay Time

Fig.2 FM-CW Principle

When the signal frequency-modulated by liner is transmitted toward clouds, and the reflection signal that has delay time from a target is received. A difference in frequency between the transmitting signal and the receiving signal, the beat frequency, is in proportion to the delay time, and delay time depends on a distance to the target. A distance to the target r is shown in the eq.(1),

$$r = \frac{cT_m}{4\Delta F} f_b \quad (1)$$

where c is the velocity of light, f_b is beat frequency, ΔF is frequency sweep width, T_m is modulation interval. We can find a distance to the target from the frequency of the beat signal, and we can find a scattering intensity of the target from the intensity of the beat signal, too.

3. THE RADAR SYSTEM

The outline of the new monostatic radar system to compare with the bistatic radar system is summarized and shown in Table I and Fig.3.

Table I. The comparison of the two radars

Radar	monostatic	bistatic
Frequency	94.84GHz	94.79GHz
Output power	500mW (27dBm)	
Antenna type	Cassegrain	
Diameter of antenna	1.4m	1m
Antenna gain	60dBi	57dBi
Antenna beam width	0.13degree	0.18degree
Direction of antenna	zenith	
NF of Receiver	4.6dB(LNA)	5dB(LNA)

Though the antenna of the monostatic radar is larger than another, it is smaller on the whole of the radar system.

The block diagram of the radar is shown in the Fig.4.

As for the configuration of the system of the radar, both radars are fundamentally the same. To transmit the signal which is very high frequency in the stability, the super-heterodyne system is adopted. The system is using two signal generators, one of them is being used for transmitting signal, another is being used for local, and transmitting signal is up-converted to millimeter-wave. The receiving signal with the antenna is down-converted to the intermediate frequency, and it is mixed with the transmitting signal. The beat signal is finally outputted, and this signal is inputted to the A/D converter of the personal computer. When FFT process is done with the personal computer and divided into each frequency component, we can know the profiling of clouds.

A conclusive difference is that it is devised so that it can do transmission and receiving with same antenna. The FM-CW radar always transmits signal and receives, unlike a pulse radar that transmission and receiving are divided at the time. In the pulse radar, even if a transmitting signal leaks to the receiver, a problem doesn't happen on that principle. But in the FM-CW radar, when a transmitting signal leaks to the receiver, a very weak reflection signal from the cloud is masked by leakage power. Therefore, this thing is very important for the FM-CW radar.

To realize the FM-CW radar, the transmitter and the receiver are isolated electrically by installing a circulator, and moreover the cancel system is being used.



Fig.3 The developed bistatic (left) and the monostatic (right) FM-CW cloud profiling radar at 95 GHz. The diameter of the antenna is 1m for the bistatic radar and 1.4m for the monostatic radar.

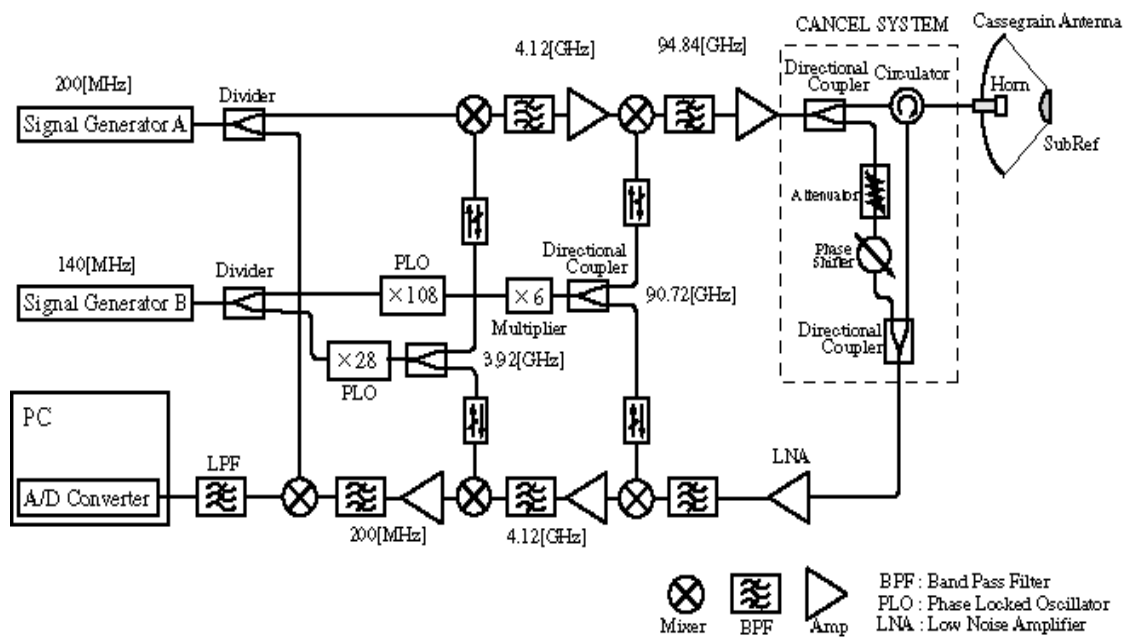

Fig.4 Block diagram of the monostatic radar

4. CANCEL SYSTEM

The cancel system is one of the most important parts in the monostatic radar. It consists from an attenuator and a phase shifter, and it is a purpose to cancel the leakage power to the receiver. Though the circulator is isolating the transmitter and the receiver mainly, but the isolation is insufficient. Therefore the cancel system exists to reduce leakage power to a limit. The cause of the leakage power is not only the performance of the circulator but also mismatching of the horn antenna and reflection from the sub-reflex, and so forth. The principle of cancel system is the simple thing that leakage power is canceled when it has added the power has the antiphase and intensity which is the same as it.

We have only to adjust the attenuator and phase-shifter in accordance with the leakage power so that the power becomes the smallest.

5. THE ALIGNMENT AND THE INITIAL EXPERIMENT

After we confirmed whether each component was being actuated normally, the alignment of the system and an initial experiment were done to evaluate the performance of the radar before actually doing observation. It confirmed that the circulator had the excellent performance; its isolation was more than 40dB as a result which measurement did.

The alignment of the cancellation system is especially very important. When a transmitting signal isn't modulated, we succeeded in reducing leakage power about 15dB as a result of adjusting it.

Next, a reflection experiment was done for a building which is as a target to ascertain whether it had performance as radar. We confirmed whether a distance to the building which left it from the radar about 70m could be measure precisely. The radar measured a distance to the building with about 65m, and confirmed that it had fundamental performance as radar from the result of the observation. So, the initial experiment has succeeded. But, much spurious was confirmed with that observation, too. Because leakage power was still strong, the cause of the spurious may be the saturation of the receiving amplifier by it, or it may be observed to the weak spurious of transmitting signal.

Even if it is whichever, if leakage power is reduced less much, a reflection signal from the cloud is buried, and it isn't likely to be able to be observed.

On the theory, though the cancel system seems to be terribly easy, but in fact it is very difficult because it is the FM-CW radar. When there is a difference in distance of the path between the leakage power and the cancellation signal, leakage power isn't reduced, a beat signal corresponding to the difference appears. If beat frequency is very low, though observation can be done when instantaneous magnitude is small, that is very difficult. If the cause of the leakage power

is plural and the distance of the path is respectively different, the number of cancellation systems may become plural necessity.

6. CONCLUSION

We began the development of the monostatic FM-CW radar of the high sensitivity. It confirmed that the prototype of monostatic radar had fundamental performance as radar from the result of the reflection experiment. But, leakage power is still strong, therefore, it couldn't get the performance which can be actually observed. If leakage power is fully reduced, it is anticipated that it can be observed in the high sensitivity.

ACKNOWLEDGEMENT

This work was supported in part with the project APEX (Asian Atmospheric Particle Environment Change Studies) in CREST (Core Research for Evolutional Science and Technology) of Japan Science and Technology Corporation, the Grant-in- Aid for Scientific Research by the Japanese Ministry of Education, Culture, Sports Science and Technology 1438024 and 18310006, Global Environment Research Fund of Japanese Ministry of the Environment B-02-04 (ACECAP), and open use programs in the Center for Environmental Remote Sensing, Chiba University (#17-P1, #18-P3-42).

REFERENCES

- [1] Horie, H., T.Iguchi, H.Hanado, H.Kuroiwa, H.Okamoto, and H.Kumagai, "Development of a 95-GHz cloud profiling radar (SPIDER) – Technical aspects", The Transactions of the Institute of Electronics, Information and Communication Engineers, Vol.E83-B, No.9, p.2010, 2000.
- [2] Kumagai, H., H.Okamoto, H.Horie, H.Kuroiwa, and S.Iwasaki, "Vertical profiling of liquid cloud properties retrieved from 95-GHz cloud radar and microwave radiometer", 2001 Asia-Pacific Radio Science Conference (Tokyo), PF-27 (p.333), 2001.
- [3] Takano, T., Y.Suga, K.Takei, Y.Kawamura, T.Takamura, H.Kumagai, and T.Nakajima, "Development of a Cloud Profiling FM-CW Radar at 94GHz", Proceedings of the 27nd General Assembly of the International Union of Radio Science (URSI) (Maastricht), FP-11, p1789, 2002.
- [4] Takano, T., Y.Suga, K.Akita, Y.Kawamura, H.Kumagai, T.Takamura, Y.Nakanishi, and T.Nakajima, "First observational results with the newly developed cloud profiling FM-CW radar at 95GHz", The International Society for Optical Engineering (SPIE) Symposium on Remote Sensing 2003 (Barcelona, Spain), 5235-67,(2003.Sep.12).
- [5] Toshiaki TAKANO, Ken-ichi AKITA, Hiroshi KUBO, Youhei KAWAMURA, Hiroshi KUMAGAI, Tamio TAKAMURA, Yuji NAKANISHI, and Teruyuki NAKAJIMA, "Observations of Clouds Using a Millimeter-Wave FM-CW Radar at 95 GHz", International Association of Meteorology and Atmospheric Sciences, Beijing (China), A1-2, Aug.5, 2005.
- [6] Toshiaki TAKANO, Ken-ichi AKITA, Hiroshi KUBO, Youhei KAWAMURA, Hiroshi KUMAGAI, Tamio TAKAMURA, Yuji NAKANISHI, and Teruyuki NAKAJIMA, "Observations of Clouds with the Newly Developed Cloud Profiling FM-CW Radar at 95GHz", The International Society of Optical Engineering, Symposium on Remote Sensing, Bruges (Belgium), Sept.19, Vol.5979, No.07, 2005.