

A fundamental study on a switched-beam sector slot-array antenna in 60 GHz band

Nobuyuki TENNO Amane MIURA Takashi ITOH Makoto TAROMARU Takashi OHIRA
ATR Wave Engineering Laboratories
2-2-2 Hikaridai, Keihanna Science City, Kyoto 619-0288 Japan
E-mail: {tenno, amane, takashi.itoh, taromaru, ohira}@atr.jp

Abstract

This paper describes a switched-beam sector slot-array antenna that can be commonly used as both an access point antenna fixed on the ceiling and a user terminal antenna for practical applications of multi-gigabit wireless LAN in 60 GHz band. Print-circuit board, which is low cost and suitable for mass production, was assumed to be applied for manufacturing the antenna.

To study fundamental characteristics of sector-beam forming, one sector was extracted from the whole structure, and analysed by finite element simulation (HFSS). Secant-beam was obtained in vertical plane. The main beam was tilted to around -60 degree with the maximum gain of about 11.0 dBi at 62.5 GHz. We also proposed improved model that has a metal-plated rectangular cavity at the edge of the antenna. The model provided higher gain in oblique directions (long-distance) as well as lower gain around vertical directions (short-distance). It almost satisfied the system requirement.

1. INTRODUCTION

The role and the importance of a wireless communication increase more and more in the future ubiquitous-network society. The communication speed, like IEEE802.11a/g, is from a few Mbps to several tens of Mbps at most; it is expected to increase the transmission rate to allow users utilizing the communication environments where a lot of people handle large volumetric digital contents simultaneously.

Our goal is to put indoor multi-gigabit wireless LAN into practice, and the target of the transmission speed is 3Gbps with bit error rate less than 10^{-5} within 5 m distance in line-of-sight communication [1]. 60 GHz band is applied because frequency range sufficient for obtaining a transmission rate of Giga bps is available.

In this paper, a switched-beam sector slot-array antenna in 60 GHz band is proposed. This antenna has eight sectors where each sector antenna provides directional beam satisfying the system requirement on the antenna gain. The antenna has beam-switching mechanism to cover the entire room. Some analysis results for one sector of the antenna are described.

2. SYSTEM CONCEPT

A. Beam scanning method

Considering that the propagation loss of millimeter-wave band is much larger than that of microwave band, directional antenna is expected for both an access point (AP) and a user terminal (UT) to compensate the propagation loss. Beam-scanning range depends on the position of the antenna. When an AP is fixed on the center of ceiling, it must be scanned in 360 degree angular range in horizontal plane. When it's fixed at the corner of ceiling, it is necessary to be scanned in 90 degree angular range in horizontal plane at least. It's not realistic to obtain these wide scanning areas by using a phased array antenna in millimeter-wave band, because the electric circuit contains expensive phase shifters and amplifiers. To enable beam-scanning capability with simpler mechanism and lower cost, a switched-beam sector antenna is chosen, which has a directional antenna in each sector.

B. Beam shape

Radiation pattern of a switched beam sector antenna depends on a sector-beam shape itself.

Generally, broad beam or omni-directional antennas can cover wide area without scanning mechanism, but these can't provide high gain. On the other hand, pencil-beam antennas can provide high gain, but it must be scanned in both horizontal and vertical planes. Sector antenna is an efficient one covering the entire room as communication area. It forms an appropriate sector-beam in vertical plane. Since the beam is scanned in only horizontal plane by switching the sectors, the controlling time period needed for scanning the beam is less than that for pencil-beam antennas. In addition, sector antenna is expected to suppress intersymbol interference caused by multipath delay because of the narrow beam width.

C. Indoor wireless LAN environment

An indoor wireless LAN environment assumed in this study is shown in Fig. 1. AP and UT antennas contain radially-arranged eight sectors in horizontal plane respectively. Each sector has a secant-beam pattern in vertical plane so that it allows for receiving data with constant signal intensity in vertical plane.

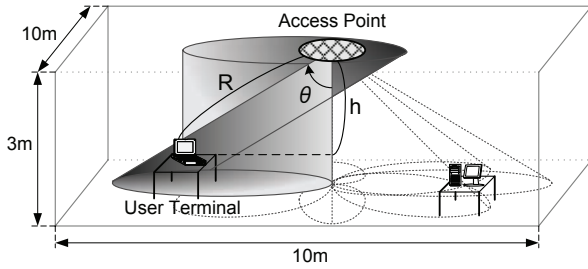

Fig. 1: Indoor wireless LAN environment in this study

A media-access control allows facing the beam-directions of AP and UT antennas to each other.

D. Link budget design

Orthogonal frequency division multiplexing (OFDM) or frequency-shift keying (FSK) is considered as modulation and demodulation methods. Table 1 shows an example of a link budget design when 8FSK is applied to the system. As indicated in Table 1, when we are going to establish communication across 5 m distance from Tx to Rx, we can keep 3.5 dB link-margin if both Tx and Rx antennas have 10 dBi gain respectively.

In Fig. 1, when h is fixed to 2 m and θ varies from 0 to ± 66 degree, the communication distance R varies from 2 to 5 m. Fig. 2 shows sum of Tx and Rx-antenna gain to satisfy the link budget design. There are three antenna-gain curves to keep the link margin as 0, 3, and 6 dB. These curves are proportional to $\sec\theta$. The 0 dB curve is the bottom line to establish communication, and the more the link margin increases, the more steady the state of the link is.

TABLE 1: LINK BUDGET DESIGN FOR 8FSK

Modulation rate	4	Gbit/s
Frequency	62.5	GHz
Distance (between AP and UT)	5.0	m
Propagation factor	2.0	(Free space)
Tx-feeder loss	3.0	dB
Aerial power	7.0	dBm
Tx-antenna gain	10.0	dBi
Propagation loss	82.3	dB
Rx-antenna gain	10.0	dBi
Rx-feeder loss	3.0	dB
Received power	-58.3	dBm
Power per 1 bit	-153.1	dBm/Hz/bit
Noise figure	5.0	dB
Noise power (including NF)	-168.8	dBm/Hz
E_b/N_0	15.7	dB
Coding gain (FEC R=3/4)	4.0	dB
Required E_b/N_0	16.2	dB
Link margin	3.5	dB

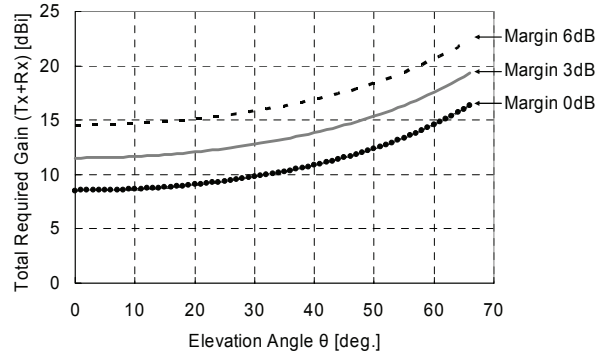

Fig. 2: Required antenna gain ($h=2m$)

3. ANTENNA STRUCTURE

A variety of switched-beam sector antennas have been reported for wireless LAN, but those contain complicated structures like a protrusion, or microstrip lines causing high loss in millimeter wave [2-4]. In this study, a waveguide slot-array antenna made of a print-circuit board (PCB) is applied, since there are some low-loss materials in PCB, and using PCB allows manufacturing planar antenna with low cost [5].

Fig. 3 shows the whole structure of the antenna. It has radially-arranged eight sectors, and each sector configures a waveguide. It also has one feed port at the center of the structure. Rectangular slots on the surface of each sector are the radiating elements to be designed to obtain a desired-radiation pattern. Each sector contains a waveguide switch to switch the sector.

This antenna can be divided into three parts as follows.

- (i) A waveguide slot-array antenna that can obtain desired radiation pattern.
- (ii) A waveguide switch that can switch the sectors.
- (iii) A feeder structure that can divide the input power from feed port into eight ways evenly and losslessly.

In this paper, only the antenna part (part (i)) is studied. One sector is extracted from the whole structure and analyzed as a fundamental study of the waveguide slot-array antenna.

4. ANALYSIS MODEL

Fig. 4 shows an analysis model of one sector. For manufacturing this antenna on mass production lines, we use PCB: thickness is 1.2 mm, relative permittivity (ϵ_r) is 2.17 and dielectric loss tangent ($\tan\delta$) is 0.0006. The sector is a waveguide consisting of upper and lower copper-thin films, dielectric body, and via holes. Those via holes work as a metal plate by arranged at appropriate intervals [6-7]. In this case, considering the accuracy in existing processing technique, the radius of a via hole (r) is 0.15mm and center-to-center spacing (d) is 0.5mm.

5. ANALYSIS RESULTS

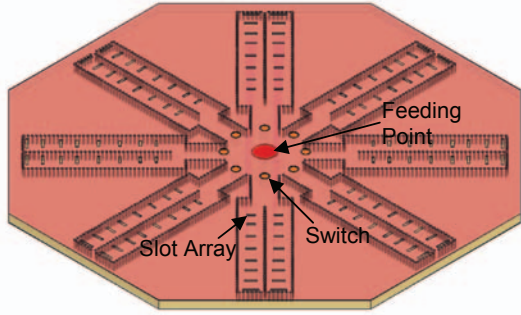

Fig. 3: Antenna structure

We use a coaxial line to feed the antenna. Coaxial feeding is suitable for the sector antenna switching in horizontal plane, because its dominant mode is TEM. As shown in the window in Fig. 4, the edge of inner conductor has taper structure for suppressing reflected power to feeder. To design the radiation pattern of the slot array itself, this analysis model doesn't contain the waveguide switch.

We analysed this model by finite element simulation (HFSS). First, the size of Slot-1 farthest from feeder is decided; the length is 1.9 mm ($0.5\lambda_m$) and the width is 0.3 mm ($0.08\lambda_m$). The λ_m denotes the average wavelength: $\lambda_m = \lambda_0 / \sqrt{(1 + \epsilon_r)/2}$, and λ_0 is free-space wavelength at 62.5 GHz. Then, the spacing between Slot-1 and via holes arranged in line at the end of the waveguide (s) is decided to be 0.5 mm (about $0.1\lambda_g$) to tilt the main beam to about $\theta = -60$ degree in vertical plane. The λ_g is wavelength in waveguide: $\lambda_g = 2\pi / \sqrt{(2\pi/\lambda_c)^2 - (\pi/a)^2}$, $\lambda_c = \lambda_0 / \sqrt{\epsilon_r}$ and a is width of waveguide. Finally, to obtain secant-beam and matching impedance to feeder, the rest of slots sizes and the spacings between slots are decided. The closer the distance from each slot to feeder is, the shorter the length of slot is. On the contrary, the spacing between slots is getting longer.

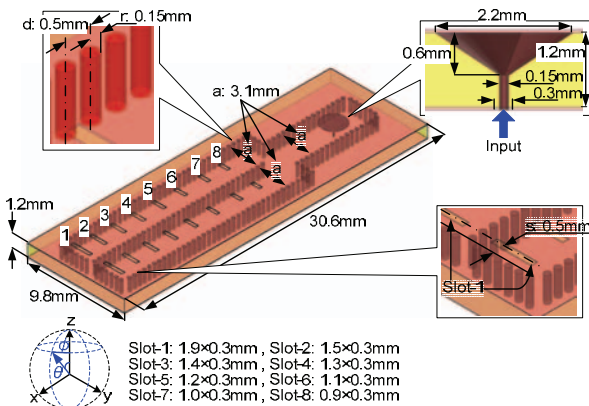

Fig. 4: Analysis model

Fig. 5 is the radiation pattern of the analysis model at 62.5 GHz. Note that the gain doesn't contain mismatch loss at the input port. The gain in the vertical axis is calculated based on its directivity and radiation efficiency.

The main beam is tilted around $\theta = -60$ degree. The maximum gain is about 11.0 dBi. At the center of the sector ($\phi = 0$ degree), the gain curve in vertical plane is almost proportional to $\sec\theta$. Half-power-beam width (HPBW) in horizontal plane is about 40 degree when θ is from -70 to -50 degree. HPBW is also over 50 degree when θ is above -50 degree.

It should be noted that the main beam is tilted to the opposite direction of the exciting-slots direction. It is referred to as backward excitation. The advantage of the backward excitation is that it can suppress the grating lobes with narrower spacing of slots than that of forward excitation [8].

Fig. 6 shows the S_{11} of the antenna. The impedance bandwidth (S_{11} less than -10 dB) was about 3 GHz. In our system, we consider OFDM and FSK as modulation methods. The assumed modulation bandwidth will be about 1.2 GHz for OFDM, and about 3GHz for FSK. Therefore, the analysis result almost satisfied the bandwidth requested from both modulation methods for one channel.

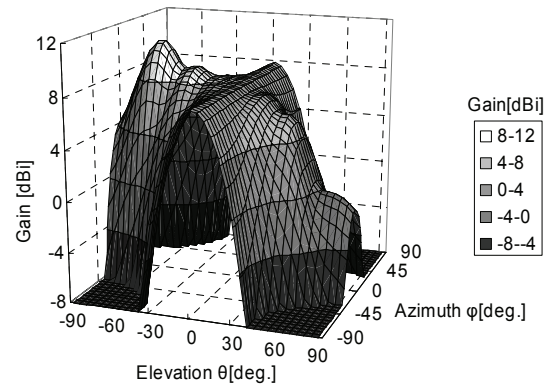

Fig. 5: Radiation pattern (62.5GHz)

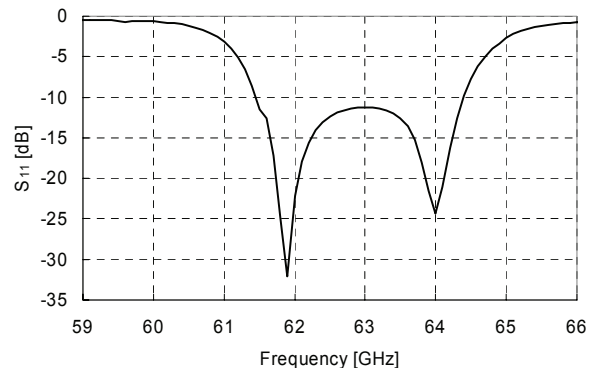

Fig. 6: S_{11} characteristics

6. IMPROVED MODEL AND ANALYSIS RESULT

Fig. 7 shows two radiation patterns in vertical plane at 62.5 GHz; one is at the center of the sector ($\phi=0$ degree) and the other is at the boundary between two sectors ($\phi=22.5$ degree). Minimum required gain is also plotted in the figure.

As indicated in Fig. 7, sufficient margin of 3 to 4 dB is observed at the center of the sector ($\phi=0$ degree). It means that at the center of the sector, it is enough to establish communication within 2 to 5m distance (When $h=2$ m and θ varies from 0 to -66 degree, R varies from 2 to 5 m). On the contrary, the gain around $\theta=-65$ degree is below the minimum required gain at the boundary between two sectors ($\phi=22.5$ degree). This should be overcome to establish the communication link in the entire communication area.

Fig. 8 shows an improved model that has a metal-plated rectangular cavity at the edge of the antenna. Fig. 9 shows radiation patterns for the improved model in vertical plane at 62.5 GHz. At the center ($\phi=0$ degree), the gain around $\theta=-60$ degree increases for about 1.4 dB as well as it decreases for about 2dB around $\theta=0$ degree compared with the model without the cavity. Similarly, at the boundary ($\phi=22.5$ degree), the gain around $\theta=-60$ degree increases for about 1 dB as well as it decreases for about 2 dB around $\theta=0$ degree. As the result, the gain satisfies the minimum required gain at the boundary as well as the center at 62.5 GHz.

Then, the improvement effect on the antenna gain from the view point of the frequency characteristics is studied. Fig. 10 shows the sum of Tx and Rx gain when the transmission distance R is 2, 3, 4, and 5 m (h is fixed to 2 m and θ is 0, -48 , -60 , and -66 degree respectively). Tx and Rx use the same antenna. In Fig. 10, the gain for the model described in Fig. 4 (Model 1) is plotted by asterisks, the gain for the model described in Fig. 8 (Model 2) is plotted by black diamonds, and the dashed line is the minimum required sum of Tx and Rx gain. In the case of the center as indicated in Fig. 10(a), when the transmission distance R is 2 m, Model 2 loses the gain 2 to 4 dB compared with Model 1.

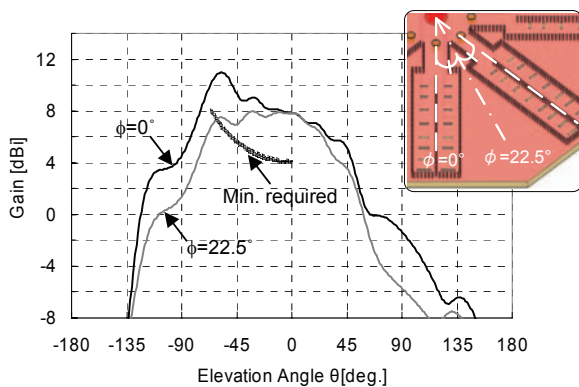

Fig. 7: Radiation patterns in vertical plane

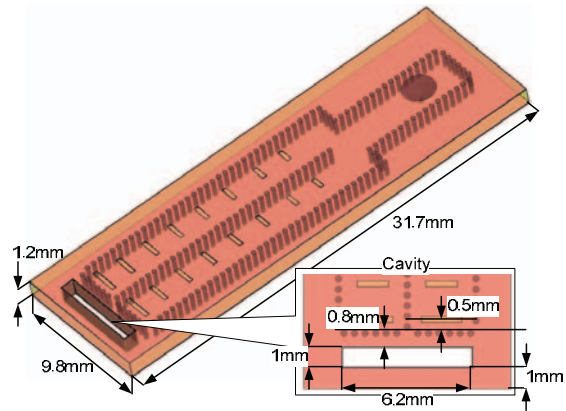

Fig. 8: Improved analysis model

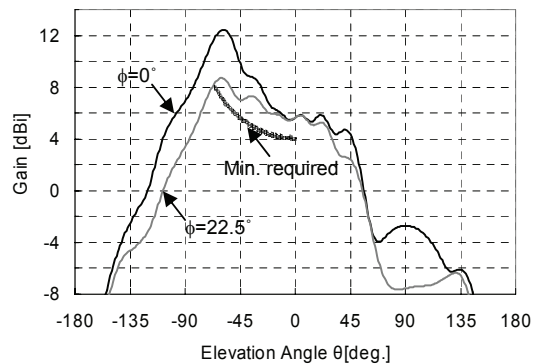

Fig. 9: Radiation patterns for the improved model in vertical plane

On the contrary, when R is over 3 m, Model 2 gets the gain up to about 4 dB more than Model 1. The same applies to the case of the boundary as indicated in Fig. 10(b).

These result indicates that Model 2 provided higher gain in oblique directions (long-distance) as well as lower gain around vertical directions (short-distance) compared with Model 1 (the model without cavity).

Fig. 10 also indicates that the improved model provides wider bandwidth than the previous model. It almost satisfied the system requirement. The worst case is indicated in Fig. 10(b)-(iv), the bandwidth over the required gain was about 2 GHz.

7. CONCLUSION

We proposed a switched-beam sector slot-array antenna that can be used as both an access point antenna fixed on the ceiling and a user terminal antenna for practical applications of multi-gigabit wireless LAN in millimeter wave band. Print-circuit board was assumed to be applied for manufacturing the antenna on mass production lines with low cost.

To study a fundamental characteristics of sector-beam forming, one sector was extracted from the whole structure,

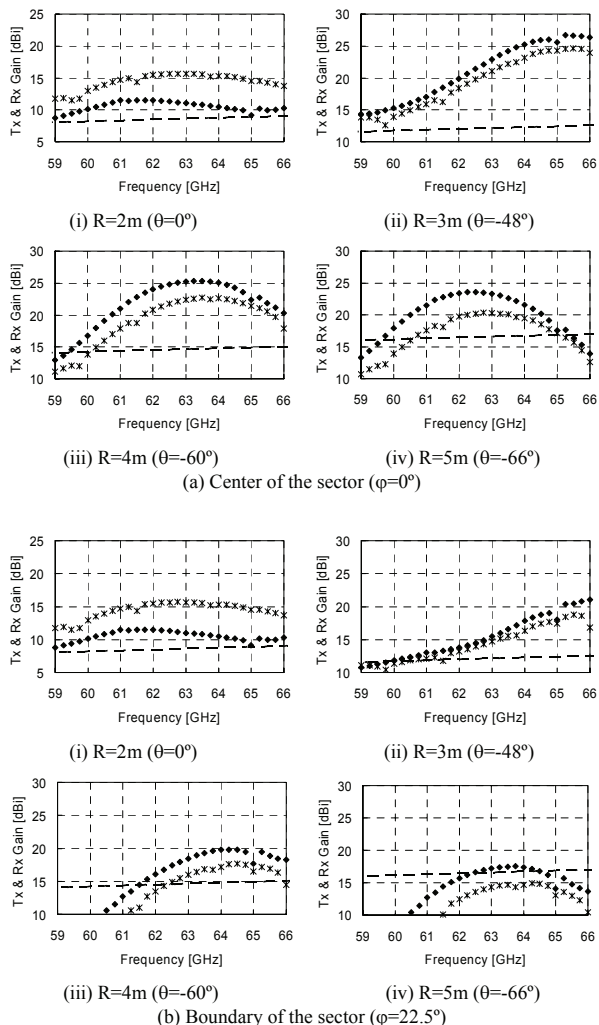

*: By Model 1, ◆: By Model 2, Dashed line: Minimum required gain
 Fig. 10: Frequency characteristics of sum of Tx and Rx gain

and analyzed by finite element simulation. The obtained sector-beam was almost proportional to $\sec\theta$ in vertical plane. The main beam was tilted around $\theta=-60$ degree. The maximum gain was about 11.0 dBi at 62.5 GHz.

The improved model that has a metal-plated rectangular cavity at the edge of the antenna was also proposed. This model provided higher gain in oblique directions (long-distance) as well as lower gain around vertical directions (short-distance) than the model without cavity. It almost satisfied the system requirement.

ACKNOWLEDGEMENT

This work is part of "Research and development of ultra-high speed giga-bit rate wireless LAN systems" granted by the National Institute of Information and Communication Technology (NICT).

REFERENCES

- [1] T. Ohira, "Prospective System Design for Gigabit Rate Wireless Local Area Networks (invited)", International Joint Conference of the 6th MINT Millimeter-Wave International Symposium, MINT-MIS/TSMW 2005, Seoul, pp.251-254, Feb. 2005.
- [2] T. Maruyama, K. Uehara, K. Kagoshima, "Design and analysis of small multi-sector antenna for wireless LANs made by monopole Yagi-Uda array antenna," IEICE Trans. Commun. Vol.J80-B-II, No.5, pp.424-433, May 1997.
- [3] Y. Murakami, H. Iwasaki, T. Kijima, A. Kato, T. Manabe, T. Ihara, M. Fujise, "A Four-Sector Shaped-Beam Antenna for 60-GHz Wireless LANs", IEICE Trans. Electronics Vol.E82-C No.7 pp.1293-1300, July. 1999.
- [4] T. Seki, T. Hori, "Cylindrical Multi-Sector Antenna with Self-Selecting Switching Circuit", IEICE Trans. Commun., Vol.E84-B, No.9, pp.2407-2412, Sept. 2001.
- [5] S. Yamamoto, N. Hikino, J. Hirokawa, M. Ando, "A Post Wall Waveguide Slot Array with a Three-Way Power Divider on a Single-Layer Dielectric Substrate", IEICE Trans. Commun. Vol.E88-B, No.4 pp.1740-1742, April 2005.
- [6] T. Fukunaga, K. Hatanaka, "Development of laminated waveguide filter", 10th International Symposium on Microwave and Optical Technology, Fukuoka, pp.449-452, Aug. 2005.
- [7] X. Xu, R. G. Bosisio, K. Wu, "A New Six-Port Junction Based on Substrate Integrated Waveguide Technology", IEEE Trans. Microwave Theory and Techniques, Vol. 53, No. 7, pp.2267-2273, July 2005.
- [8] M. Yamamoto, K. Ishizaki, M. Muramoto, K. Sasaki, K. Itoh, "Cavity-backed slot array antenna with backward excitation", Electronics and Communication in Japan, Part I, Vol.85, No.11, pp.68-76, May 2002.