

DESIGN OF PLANAR AND CYLINDRICAL MICROSTRIP PATCH ANTENNAS AND ARRAYS FOR SMART ANTENNA APPLICATIONS

Juraj Bartolic¹, Zvonimir Sipus¹, Tuli Herscovici², Davor Bonefacic¹, Radovan Zentner¹

(1) University of Zagreb, Faculty of Electrical Engineering and Computing
 Unska 3, HR-10000 Zagreb, Croatia
 E-mail: juraj.bartolic@fer.hr

(2) Spike Technologies, Inc., Nashua, NH 03108, USA
 E-mail: tuli@ieee.org

INTRODUCTION

Over the last decade, deployment of cellular systems, personal communication systems and wireless local loop systems has been phenomenal increasing the need for new antenna designs. High-performance radiation and impedance characteristics are required in wider operating frequency bands than in earlier designs. Therefore, both uplink and downlink antennas undergo a lot of innovations, modifications and performance improvements.

This paper reports some new designs and results for wireless antennas, which have been done at the University of Zagreb in cooperation with Dr. Naftali Herscovici, Spike Technologies, Nashua, USA, and the Antenna Group, Chalmers University of Technology in Gothenburg, Sweden, and. We have developed several programs for different types of geometries, based on the electric field integral equation (EFIE) and on the moment method. In all programs the core subroutine is G1DMULT algorithm [1] which calculates the Green's functions of planar, circular cylindrical, and spherical multilayer structures in spectral domain.

SHORTED STACKED PATCH ANTENNAS FOR LINEAR POLARIZATION

A shorted antenna was constructed for broadband application (Fig 1). Basically it is a quarter wavelength stacked patch configuration with slanted top patch. Antenna dimensions in millimeters are: $W=40$, $L=32$, $d=5$, $h=7$ and $H=8$ mm. The total height of antenna is still pretty low: 15 mm or 13.5% of free space wavelength at the central frequency of 2.54 GHz. VSWR less than 2 is measured in the frequency range from 1.835 to 3.25 GHz or 55% relative bandwidth. Cross polarization levels are below 20 dB in E-plane (Fig. 2) and below 10 dB in H-plane. The main beam is shifted from normal direction for 30° in E-plane and for 46° in H-plane, respectively.

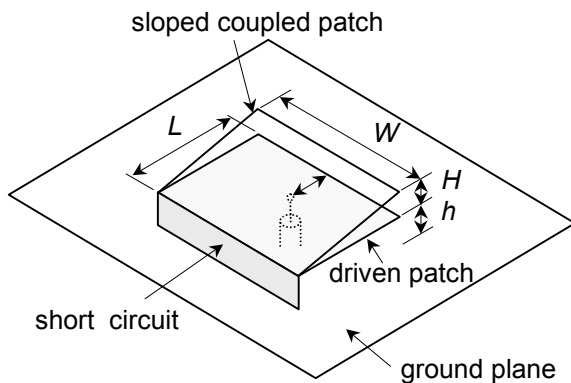

Figure 1. Quarter wavelength stacked patch antenna with sloped top patch

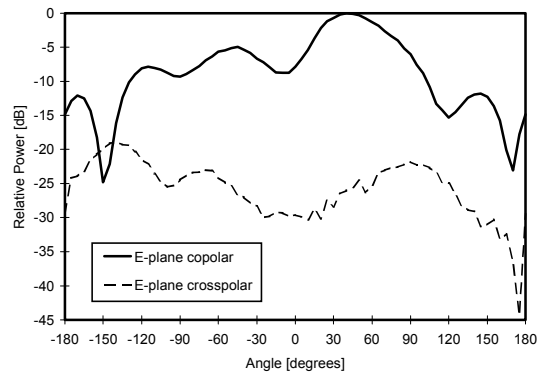

Figure 2. E-plane radiation patterns at 2 GHz for the antenna with sloped top patch

STACKED PATCH ANTENNA FOR CIRCULAR POLARIZATION

We present a broadband planar probe-fed stacked patch structure for circular polarization. Typically, microstrip antennas for circular polarization lack on small bandwidth. This is due to inherently small axial ratio-bandwidth of a single patch element. The procedure of adding a parasitic element over the driven patch in order to enhance the bandwidth, usual in linearly polarized broadband patches, is investigated in the case of the circular polarization. The results show that this approach may be applied for circularly polarized structures as well. The antenna was constructed of three conducting plates used for ground plane, driven and parasitic patch (Fig. 3). The analysis was performed using the simple Method of Moments in spectral domain [2]-[4]. The G1DMULT algorithm was used to calculate the Green's functions of planar multilayer structure in spectral domain [1], [5], whereas a moment method program computed the input impedance of a probe fed stacked patch. The entire domain basis and test functions were used, following the Galerkin procedure. In order to make the optimization procedure fast, only two basic functions per patch have been used. The driven patch was fixed on a 6.5 mm thick, low-loss foam substrate. Parasitic patch was located in the air, fixed with styrofoam spacers. The antenna was optimized to SWR and axial ratio within the desired bandwidth.

The antenna was optimized by using hybrid technique of genetic algorithm and modified Newton method [6]. Genetic algorithms are known as global search methods, insensitive to local minima, and were successfully used to approach close to the best solution. Here, a steady state genetic algorithm was used, with a population size of 60 chromosomes, out of which 12 chromosomes per generation were replaced by the offsprings. The mutation rate was 2%, and it was applied only to the offspring chromosomes. The real-coded chromosomes were used that, contrary to their binary counterparts, enabled floating-point precision of the results. To converge fast to the solution the Newton local search was used.

Fig. 4 shows the resulting SWR and axial ratio of the optimized antenna. The resulting stacked microstrip antenna is circularly polarized, with axial ratio below 4 dB in band from 1.71 GHz to 1.97 GHz, i.e. 14% of bandwidth. In the same frequency band the antenna are well matched with VSWR less than 2. The experimental results of one of the previous designs show good agreement between calculated and measured results [3].

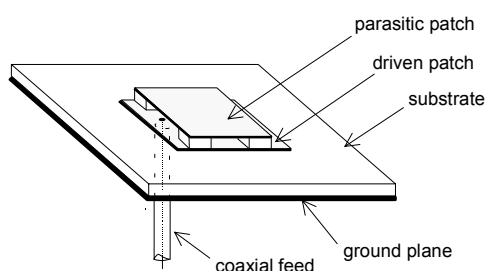

Figure 3. Stacked patch antenna for circular polarization

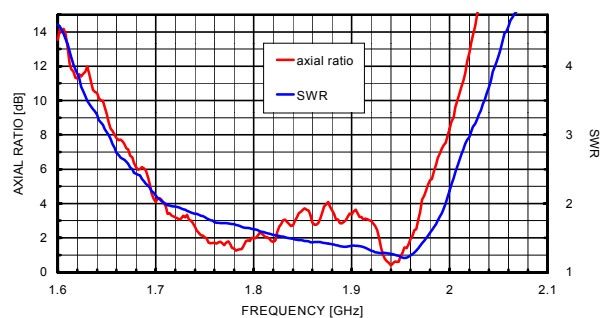

Figure 4. Axial ratio and VSWR of stacked patch antenna for circular polarization

ALMOST WRAPPED-AROUND STACKED PATCH ANTENNA

A new design of an omnidirectional cylindrical stacked patch antenna overcomes the bandwidth limitations of the single patch version [7]. As shown in Fig. 5 it consists of a cylindrical ground-plane coaxial to a cylindrically shaped patch fed by a coaxial feed. Like in the planar case the location of the excitation determines the polarization of the antenna, which can be linear (axial or circumferential) or circular [8]. Antenna is analyzed using the moment method, and the Green's functions of a circular-cylindrical multilayer structure is calculated by using G1DMULT [4], [5]. The dimensions of each patch and the placement of the feeding point are optimized in order to get desired performances.

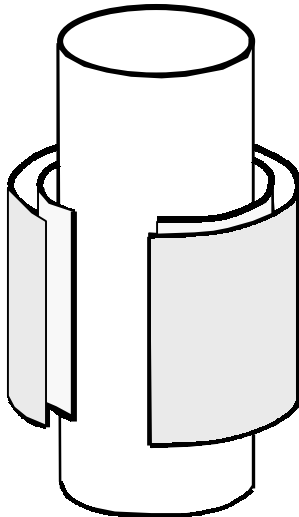

Figure 5. Stacked patch wrapped-around antenna

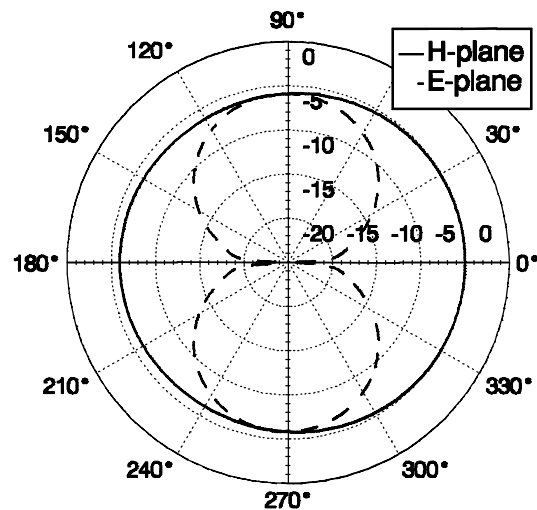

Figure 6. Radiating patterns of the wrapped-around stacked patch

Numerical results show that the stacked-patch antenna with the opening of 45 degrees had omnidirectionality of 1.2 dB, as shown in Fig. 6 (the working frequency was 1.92 GHz; the antenna was polarized in the axial direction). The antenna was designed for the frequency band 1.85- 1.99 GHz, in which VSWR was less than 2 [9].

CYLINDRICAL CIRCULAR PATCH ARRAYS ON MULTILAYER STRUCTURES

We have developed a program for analyzing the arrays of rectangular patches placed on a multilayer circular cylinder (Fig. 7). We assumed that the patches of the same dimensions are placed periodically in the circumferential and axial directions. Two types of the feeding structure are considered: a coax feeding and a microstrip line feeding. The program calculates input impedance of each patch in the array, mutual coupling between any two patches in the array, as well as the radiation pattern. Fig. 8 shows the radiation pattern in the azimuthal plane of the 12-patch array (the patches were axially polarized). The radius of the array was 2λ , and the distance between patches in the circumferential direction was 0.52λ . In order to obtain the needed bandwidth we used the foam as dielectric. In Fig. 8 two cases are shown: when 5 and 7 elements are active. In the case of 7 active element the beamwidth is narrower. However, the sidelobes are smaller in the case of 5 active elements, which can influence the choice how many active elements to use to excite the beam. More results calculated by this program are presented in [10].

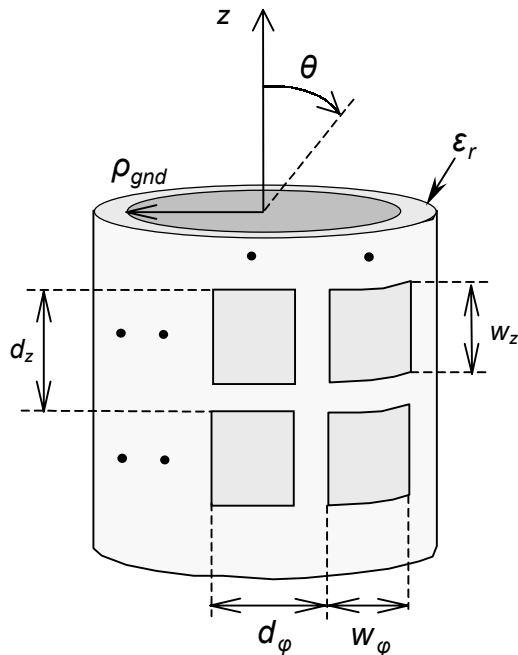

Figure 7. Cylindrical patch array

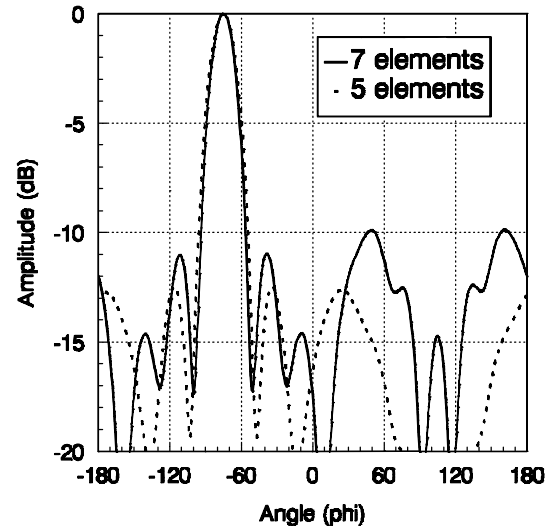

Figure 8. Radiation pattern of cylindrical patch array

REFERENCES

1. Sipus, Z., Kildal, P-S., Leijon, R., Johansson, M., "An algorithm for calculating spectral domain Green's functions for planar, circular cylindrical and spherical multilayer structures", *ACES Journal*, **13**, (1998), pp. 243-254.
2. Pozar, D.M., "Input impedance and mutual coupling of rectangular microstrip antennas", *IEEE Transactions on Antennas and Propagation*, **30** (1982), pp. 1191-1196.
3. Herscovici, N., Sipus, Z., Bonafacic, D., "Circularly polarized single-fed microstrip patch for wireless communications", *Proc. of the 1998 IEEE AP-S Conference on Antennas and Propagation for Wireless Communications*, Waltham, 1998, pp. 167-170.
4. Herscovici, N., Sipus, Z., Bonafacic, D., "Circularly polarized single-fed wide band microstrip elements and arrays", *Proc. of the 1999 IEEE AP-S Conference on Antennas and Propagation*, Orlando 1999, pp. 280-283.
5. Z. Sipus, and P-S. Kildal, "Analysis of conformal antennas on multilayer circular cylindrical and spherical structures by using G1DMULT," *Proceedings of the Millennium Conference on Antenna and Propagation*, AP 2000, 9-14 April 2000, Davos, Switzerland.
6. R. Zentner, Z. Sipus, "Some aspects of optimization of broadband circularly polarized microstrip antennas", *Proceedings of the 15th International Conference on Applied Electromagnetics and Communications – ICECOM'99*, Dubrovnik 1999, pp.75-78.
7. N. Herscovici, Z. Sipus, P.-S. Kildal, "The cylindrical omnidirectional patch antenna", *Proceedings of IEEE International Symposium on Antennas and Propagation*, Montreal, 1997, pp. 924-927.
8. Z. Sipus, N. Herscovici, and D. Bonafacic, "The circularly polarized cylindrical patch", *Proceedings of IEEE Conference on Antennas and Propagation for Wireless Communications*, Waltham (MA), 1998, pp. 145-148.
9. Z. Sipus, N. Herscovici, "Cylindrical patch antenna for wireless communication", *Proceedings of the Millennium Conference on Antenna and Propagation*, AP 2000, 9-14 April 2000, Davos, Switzerland, CD-ROM.
10. S. Raffaelli, Z. Sipus, P-S. Kildal, "Input impedance and radiation pattern of patch on multilayer cylinder", *Proceedings of the Millennium Conference on Antenna and Propagation*, AP 2000, 9-14 April 2000, Davos, Switzerland, CD-ROM.