

TUNABLE SLEEVE ANTENNA USING VARIABLE CAPACITORS

Kengo Nishimoto, Ryosuke Umeno, Toru Fukasawa, and Masataka Ohtsuka
 Mitsubishi Electric Corporation
 5-1-1 Ofuna, Kamakura, Kanagawa 247-8501, Japan
 E-mail: knisimot@isl.melco.co.jp

1. Introduction

We propose a tunable sleeve antenna using variable capacitors. A sleeve antenna consists of the monopole with a quarter wavelength and the sleeve conductor which covers a coaxial feeder [1, 2]. The monopole and sleeve conductor are connected with the inner and outer conductors of the coaxial feeder, respectively. It can realize the radiation pattern similar to that of a dipole antenna though it has no need for a balun. Therefore, the sleeve antenna is widely used. In the sleeve antenna, the leakage current on the feeder can be suppressed only near the frequency where the length of the sleeve conductor is a quarter wavelength. Up to now, the multi-band sleeve antennas having different lengths of sleeve conductors have been investigated [3, 4], but the sleeve antennas that have the wideband characteristic have hardly ever been reported.

First, we show that, in a planar sleeve antenna [3-5], CRB (Current Rejection Band: the band within which the leakage current is suppressed) becomes wider with an increase in the antenna width. Namely, when the wideband characteristic is required, the sleeve antenna becomes large. Then, secondly, we propose a novel method to miniaturize the sleeve antenna. The proposed one is to divide the sleeve conductor into two parts and connect them by a variable capacitor. By changing the capacitance of the variable capacitor, CRB can be varied. Moreover, we show that the impedance matching is easy to realize even if the desired frequency changes.

2. The relationship between CRB and the antenna width

The relationship between CRB and the antenna width is investigated. Fig.1 illustrates a planar sleeve antenna. This antenna is actually fed by a microstrip line. However, for simplicity, the ground plane of the microstrip line is treated as a long, narrow conductor (GND) as shown in Fig.1. We assume that GND is infinite to the downside of Fig.1. The FDTD simulations are performed for $l_m=0.25\lambda_c$, $w_m=0.066\lambda_c$, $l_s=0.25\lambda_c$ and $w_l=0.016\lambda_c$, where λ_c is the center wavelength of a design. The parameters are w_s and d .

Fig.2 shows frequency versus $|I_l / I_f|$ when w_s is fixed to $0.016\lambda_c$, where I_l is the leakage current and I_f is the feed current. In Fig.2, f_c is the center frequency of a design. The calculated I_l is the current at BB' of GND. Note that CRB becomes wider with an increase in d . Fig.3 shows frequency versus $|I_l / I_f|$ when w_s+d is fixed to $0.058\lambda_c$. Note that the width of CRB is almost constant when d changes. In summary, Figs.2 and 3 state that the width of CRB depends on w_s+d , and it becomes wider with an increase in the antenna width (w_s+d).

3. Theory

As shown in Chap.2, when the wideband characteristic is required, the sleeve antenna becomes large. Then, we propose a novel sleeve antenna whose size is miniaturized by tuning CRB, as shown in Fig.4. The sleeve conductors divided into sleeve conductors #1 and #2, and they are connected by variable capacitors. The sleeve conductors #1, #2 and GND compose coplanar strips lines. The capacitances of two variable capacitors are the same. When the impedances of the coplanar strips lines are infinite at AA' of Fig. 4, the leakage current flowing on GND below AA' can be suppressed. Assuming that the coplanar strips lines have no loss, the capacitance where the impedances of the coplanar strips lines are infinite at AA' becomes

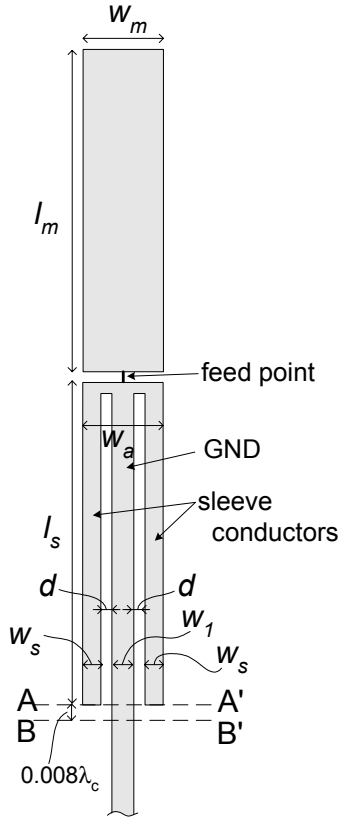

Fig.1. A planar sleeve antenna.

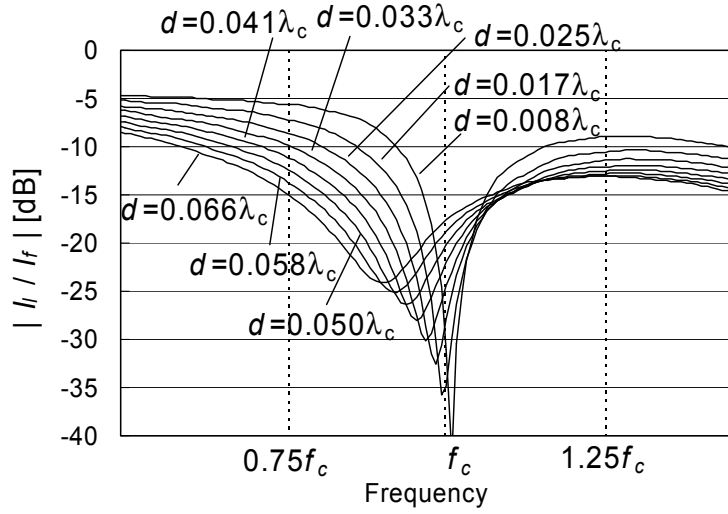

Fig.2. Frequency versus $|I_l / I_f|$ when $w_s = 0.016\lambda_c$. The calculated I_l is the current at BB' of GND.

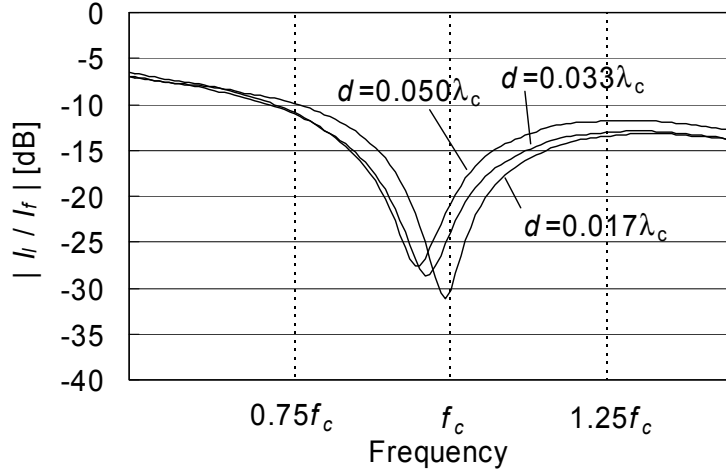

Fig.3. Frequency versus $|I_l / I_f|$ when $w_s + d = 0.058\lambda_c$. The calculated I_l is the current at BB' of GND.

$$C = \frac{-\tan(\beta l_{s2})}{Z_0 \omega (1 - \tan(\beta l_{s1}) \tan(\beta l_{s2}))} \quad (1)$$

where l_{s1} and l_{s2} are the lengths of the sleeve conductors #1 and #2, respectively. Z_0 is the characteristic impedance of each coplanar strips line, ω is the angular frequency and β is the wave number. At the desired frequency, the leakage current can be suppressed by changing the capacitances of the variable capacitors according to Eq.(1).

4. Numerical results

In this section, the above characteristics are validated by the FDTD simulations. The simulations are performed for $l_m=0.25\lambda_c$, $w_m=0.066\lambda_c$, $d=0.008\lambda_c$, $w_l=0.016\lambda_c$ and $w_s=0.016\lambda_c$ in Fig.4. The characteristic impedance of each coplanar strips line is 198.35Ω [6]. We assume that the capacitances of the variable capacitors change from $0.0019 / \omega_c$ [F] to $0.0195 / \omega_c$ [F], where $\omega_c=2\pi f_c$. Also, we consider that the impedances of the coplanar strips lines at AA' become infinite from $0.80f_c$ to $1.15f_c$. Under these conditions, the smallest value of $l_{s1}+l_{s2}$ is estimated at $0.35\lambda_c$ from numerical calculations,

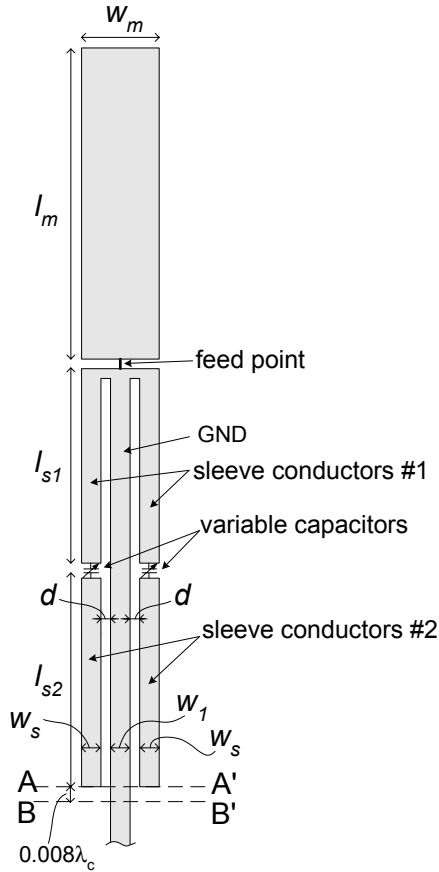

Fig.4. A planar sleeve antenna with variable capacitors.

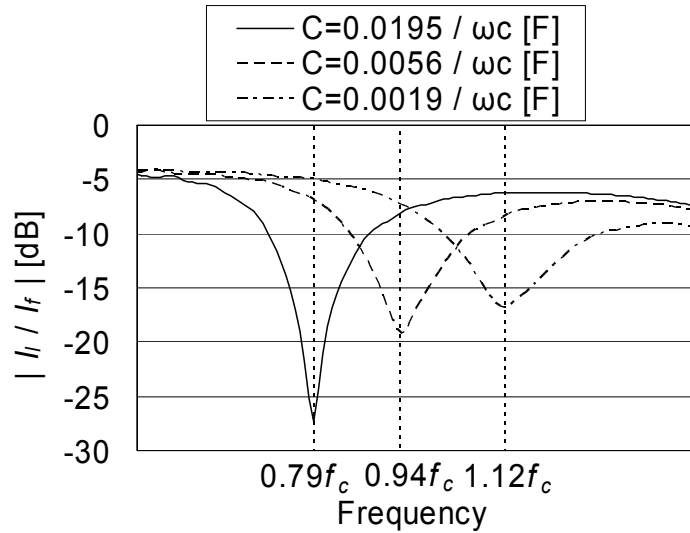

Fig.5. Frequency versus $|I_l / I_f|$. The calculated I_l is the current at BB' of GND.

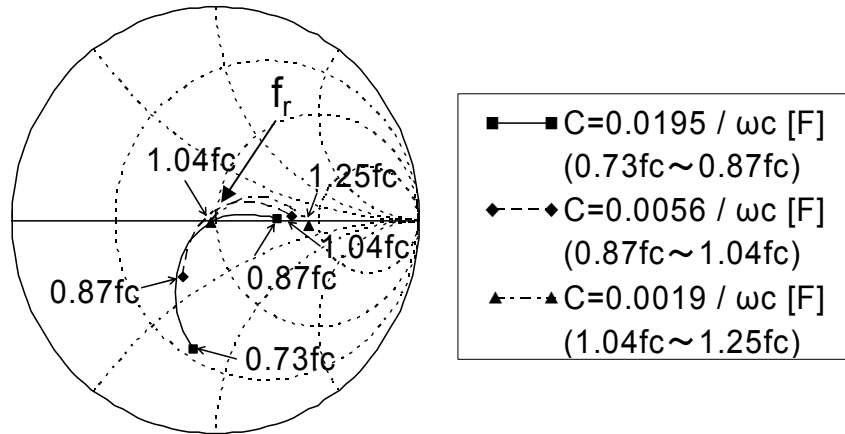

Fig.6. Input Impedances. $Z_0=75\Omega$ at the center.

l_{s1} and l_{s2} being $0.17\lambda_c$ and $0.18\lambda_c$ respectively.

Fig.5 shows frequency versus $|I_l / I_f|$ at $C=0.0195 / \omega_c$, $0.0056 / \omega_c$, $0.0019 / \omega_c$ [F]. The calculated I_l is the current at BB' of GND. Note that the frequencies where $|I_l / I_f|$ becomes minimum are $0.79f_c$, $0.94f_c$ and $1.12f_c$ at $C=0.0195 / \omega_c$, $0.0056 / \omega_c$, $0.0056 / \omega_c$ [F] respectively. Namely, the frequency where the leakage current is suppressed increases with a decrease in C .

The input impedances are calculated at $C=0.0195 / \omega_c$, $0.0056 / \omega_c$, $0.0019 / \omega_c$ [F] as shown in Fig.6, when the characteristic impedance of the feeder is 75Ω . In Fig.6, we consider the frequency

range within which $|I_l / I_f|$ at BB' is less than -11dB. (At this time, the leakage current is almost suppressed.) Namely, Fig.6 shows the input impedances from $0.73 f_c$ to $0.87 f_c$ at $C=0.0195 / \omega_c$ [F], from $0.87 f_c$ to $1.04 f_c$ at $C=0.0056 / \omega_c$ [F], and from $1.04 f_c$ to $1.25 f_c$ at $C=0.0195 / \omega_c$ [F]. If we define a resonant frequency f_r as the frequency where the imaginary part of the input impedance becomes zero as shown in Fig.6, $f_r = 0.79f_c, 0.91 f_c, 1.05 f_c$ at $C=0.0195 / \omega_c, 0.0056 / \omega_c, 0.0019 / \omega_c$ [F] respectively. Briefly, the resonant frequency, as well as the frequency where the leakage current is suppressed, increases with a decrease in C . In other words, the frequency where the leakage current is suppressed and the resonant frequency change to the same direction with a change in C . Therefore, the proposed sleeve antenna has an advantage in that the impedance matching is easy to realize even if the desired frequency changes.

5. Conclusions

We have proposed a novel method to miniaturize the sleeve antenna. The proposed one is to divide the sleeve conductor into two parts and connect them by a variable capacitor. By changing the capacitance of the variable capacitor, CRB can be varied. These characteristics have been validated by the FDTD simulations. Moreover, we have found that the frequency where the leakage current is suppressed and the resonant frequency change to the same direction with a change in C . Therefore, the proposed sleeve antenna has an advantage in that the impedance matching is easy to realize even if the desired frequency changes.

References

- [1] K. Ito, Y. Komura, and N. Goto, "Characteristics of a sleeve antenna," Tech. Rep. Group IECE Japan, AP77-55, Oct. 1977 (in Japanese).
- [2] M. Taguchi, S. Egashira, and K. Tanaka, "Sleeve antenna with ground wires," IEEE Trans. Antennas Propagat., vol. 39, no. 1, pp. 1-7, Jan. 1991.
- [3] Y. Nishioka, T. Fukasawa, and H. Ohmine, "Dual-band planar sleeve antenna for portable wireless terminal," IEICE Gen. Conf., B-1-122, Mar. 2001 (in Japanese).
- [4] T.-L. Chen, "Multi-band printed sleeve dipole antenna," Electron. Lett., vol. 39, no. 1, pp. 14-15, Jan. 2003.
- [5] Y. Yoshikawa, Y. Sunahara, and M. Matsunaga, "Coil loaded sleeve antenna fed by microstrip line," IEICE Autumn Natl. Conv. Rec., B-104, Oct. 1990 (in Japanese).
- [6] B.C. Wadell, Transmission Line Design Handbook, pp. 83-84, Artech House, Dedham MA, 1991.