

3-D Angular Spectrum Measurements in a Residential House at 5GHz

#H. Iwai¹, T. Sakata¹, A. Yamamoto¹, K. Ogawa¹, K. Sakaguchi², K. Araki²

¹Network Development Center, Matsushita Electric Industrial Co., Ltd.

1006 Kadoma, Kadoma-shi, Osaka, 571-8501 Japan, iwai.hiroshi@jp.panasonic.com

²Graduate School of Science and Engineering, Tokyo Institute of Technology
2-12-1, Ookayama, Meguro-ku, Tokyo, 152-8550 Japan

Abstract

This paper presents an investigation of radio-wave propagation characteristics in the 5 GHz band in a residential two-story house. We investigated the 3-D angular spectra of incident waves when a transmitter and a receiver were set on the first floor and on the second floor, respectively. It was found that the strongest wave arrived at the receiving antenna from the direction of the transmitting antenna, penetrating through the ceiling of the first floor. Furthermore, we estimated the channel capacities of a 4-by-4 MIMO by using a 3-D angular spectrum. From this, a 1.6-fold increase in capacity was achieved compared with that achieved in the horizontal plane by choosing a suitable elevation angle, including the direction of the transmitting antenna.

1. INTRODUCTION

The increasing demand for capacity in wireless communication systems has motivated intensive research aimed at achieving higher throughput within a given bandwidth. One of the most promising candidates for the next generation of wireless communication systems is the MIMO-OFDM system [1]. This system combines conventional Orthogonal Frequency Division Multiplexing (OFDM) technology with a Multi-Input Multi-Output (MIMO) system [2], [3]. The MIMO system, which greatly increases spectral efficiency by employing multiple antennas for both the transmitter and the receiver, is a key technology for the realization of gigabit wireless communications [4].

So far, intensive research efforts have been put into the realization of MIMO applications for wireless communication systems, and these are now at the stage where they are in use in some practical applications [5]. To realize such applications, it is essential to understand the propagation characteristics in a practical environment, because a MIMO system for wireless television is often located in the vicinity of a wall, while it is assumed that systems for mobile terminals such as notebook personal computers will be used on tables or maybe on a sofa.

In our previous report [6], the area-coverage of a 4-by-4 MIMO-OFDM system in the 5GHz band was measured in a residential house containing furniture such as beds, a sofa and

tables by using a spatial scanner and MIMO-OFDM channel measurement firmware on a MIMO prototype [7]. The results show that the MIMO system can greatly increase the area-coverage compared to a Single-Input Single-Output (SISO) system, and that the increment in channel capacity is very significant. However, a major limitation is that the measurement area is restricted to points on the same floor.

In this paper, the 3-D angular spectra of the incident waves were measured at 5.06GHz when a transmitter and a number of receivers were set on the first floor and on the second floor respectively as a basic study to evaluate the performance of such a system for MIMO applications. To ensure a quasi-static environment, there was nobody present in the house during the measurements. Time-correlation measurements verified that time correlation in the measured “home environment” was very high. The 3-D angular spectra of the incident waves on the first floor and on the second floor were measured by using a Yagi-Uda antenna. Furthermore, the channel capacity of a 4-by-4 MIMO was estimated by using the measured three-dimensional angular spectra.

2. MEASUREMENT ENVIRONMENT

The measurements were conducted in a two-story residential house, which has a base area of 15 m by 10 m. The house has two enclosed rooms plus a hallway and living and dining areas on the first floor, while there are five rooms and a passageway on the second floor. Furniture such as beds, a sofa and tables are sited in the rooms. A plan view of the house and the locations of the transmitting and receiving antennas are shown in Fig. 1.

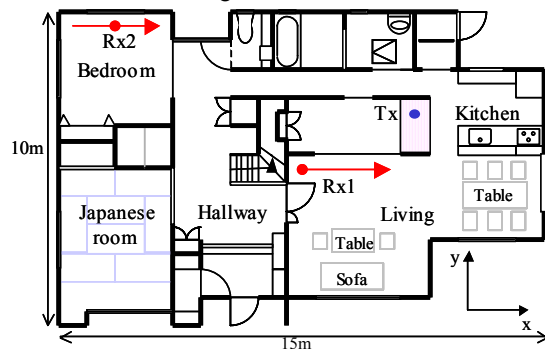

(a) First floor

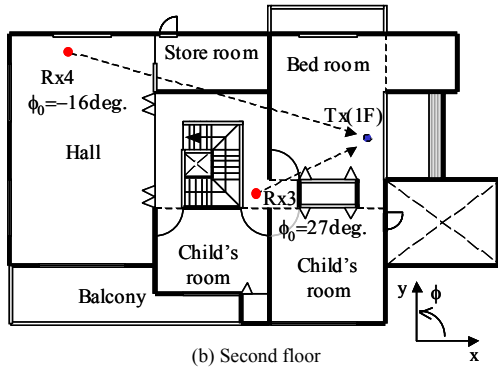

(b) Second floor
Fig. 1: Overview of measurement environment.

The measurement areas in the living room are mostly in LOS environments in the proximity of the transmitting antenna. On the other hand, the measurement areas in the bedroom on the first floor and in the passageway on the second floor are in NLOS environments, with walls, doors, furniture and the ceiling of the first floor between the transmitting and receiving antennas.

3. TIME CORRELATION MEASUREMENT

A. Experimental set-up

In this section, we investigate time correlation in the measurement environment. Figure 2 shows the experimental set-up that was used to obtain fading characteristics in the living room and in the bedroom. Half-wavelength dipole antennas were used for both the transmitting antenna (Tx) and the receiving antenna (Rx). The transmitting antenna was located vertically at a height of 1 m on a table between the kitchen and the living room. The receiving antenna was mounted vertically on a spatial scanner, also set at a height of 1 m. The spatial scanner can move the receiving antenna in the x direction i.e. along the arrows shown in Fig. 1. Radio propagation channel measurements were then performed with a step-size of 5 mm, resulting in 6,000 measurement points. The measurement frequency was 5.06 GHz.

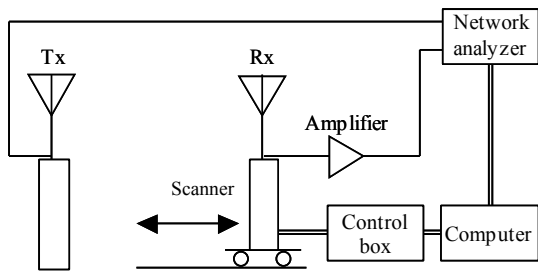

Fig. 2: Experimental set-up.

The radiation pattern of the dipole antenna in the horizontal plane is shown in Fig. 3. From Fig. 3, an omni-directional pattern with a peak gain of 0 dBi was obtained for the vertical polarization, while the maximum gain in the horizontal polarization was -25 dBi.

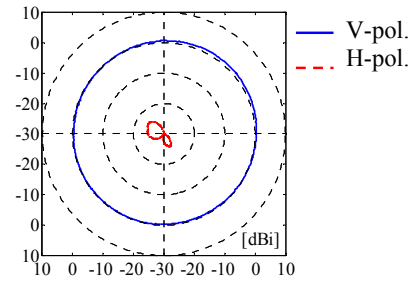

Fig. 3: Radiation patterns of the half-wavelength dipole antenna in a horizontal plane.

B. Measurement results

The instantaneous variations in received power are shown in Fig. 4. In Fig. 4, the solid and broken lines show the data that were measured at the first sampling time and second sampling time; the second measurement was performed five minutes after the first. In this case, the transmitted power, the loss due to the cable and the gain of the amplifier and of the antennas were revised. From Fig.4, the results of the second trial show good agreement with those of the first trial, not only with regard to the average values, but also in terms of the local minima and maxima.

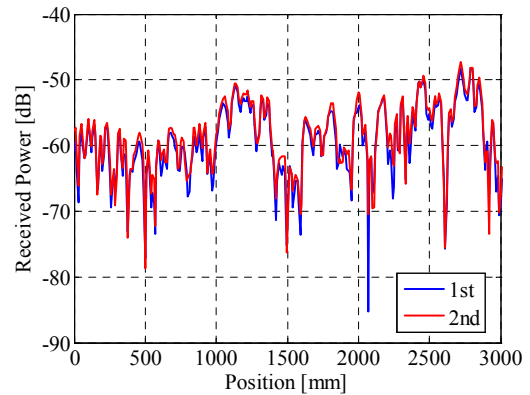

Fig. 4: Time stamp of the received power in the living room.

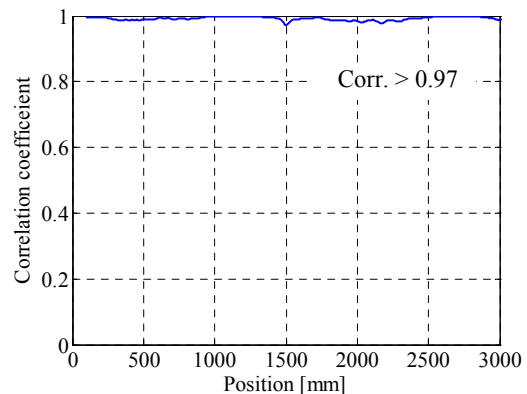

Fig. 5: Partial correlation coefficient between the measurement results of the first time and the second time.

The partial correlation coefficient is defined as the mean value of the correlation for every 12 samples between the first and second measurement results. Figure 5 shows the partial correlation coefficient. As shown in Fig. 5, the partial correlation was more than 0.97 over the whole range that was evaluated. A very high time-correlation was confirmed in a residential house environment by these experiments.

4. PROPAGATION CHARACTERISTIC BETWEEN FLOORS

A. Experimental set-up

In this chapter, the propagation characteristics between the first floor and the second floor in the residential house environment are examined. Figure 6 depicts the experimental set-up that was used to measure a 3-D angular spectrum. A transmitting antenna (Tx) with a half-wavelength dipole antenna was located on the table between the kitchen and the living room on the first floor, as shown in Fig.1. A receiving antenna (Rx) fitted with an eight-element Yagi-Uda antenna was located on a rotator at a height of 1 m. As shown in Fig.1, the receiving points on the second floor (Rx3 and Rx4) were directly above the receiving points on the first floor (Rx1 and Rx2), respectively. A vertically-polarized wave was radiated at 5.06 GHz. The elevation angle of the Yagi-Uda antenna was varied from -60 to 60 degrees with a step of 5 degrees, and was then rotated from 0 to 360 degrees in the azimuth direction for each elevation angle. Figure 7 shows the radiation patterns in the horizontal and vertical planes of the Yagi-Uda antenna. The peak gain of the Yagi-Uda antenna was 11.7dBi and the half-power angle was at 40 and 35 degrees in the horizontal and vertical planes, respectively.

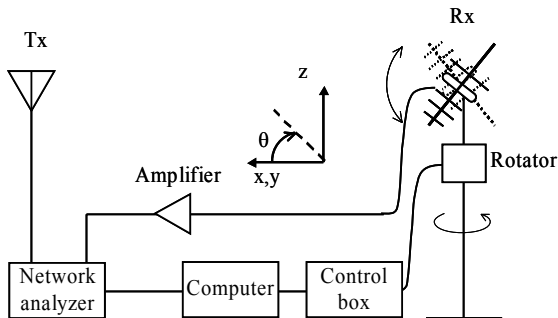

Fig. 6: Experimental set-up for 3-D angular spectrum.

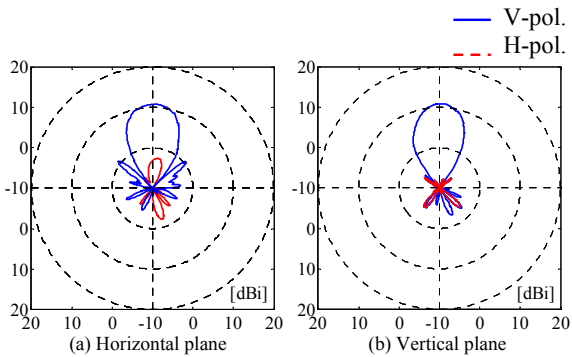

Fig. 7: Radiation patterns of the Yagi-Uda antenna.

B. Experimental results

The 3-D angular spectra of the incident waves on the first floor and on the second floor are shown in Fig. 8. The received power is normalized by the maximum power for each receiving point, and the maximum received power (P_{\max}) and its direction (θ_{\max} and ϕ_{\max}) at each point are listed in Table 1.

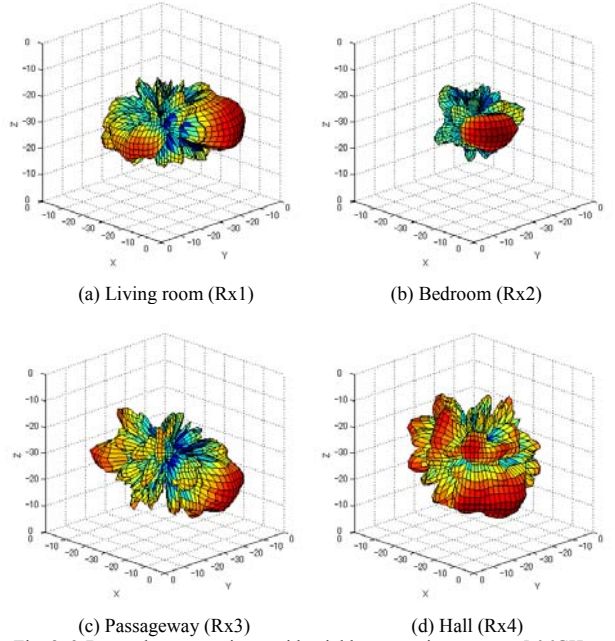

Fig. 8: 3-D angular spectra in a residential home environment at 5.06GHz.

TABLE 1: Maximum received power and its direction.

Floor		θ_{\max} [deg.]	ϕ_{\max} [deg.]	P_{\max} [dBm]
1 st	Rx1	5	41	-52.6
	Rx2	10	-31	-66.6
2 nd	Rx3	-25	26	-63.0
	Rx4	-30	-16	-82.8

Figs. 8 (a) and (b) show that, in the case of the first floor, the direction from which the received power is highest is in the horizontal plane. On the other hand, on the second floor, the received power is highest from the direction of the low-elevation angle. In this case, the strongest wave on the first floor came from an almost horizontal direction, because θ_{\max} on the first floor occurred at 5 and 10 degrees, whereas the strongest signal on the second floor propagated from a low-elevation angle, since θ_{\max} in this case occurred at -30 and -25 degrees. The azimuth angles between Tx and Rx (ϕ_0), shown in Fig.1 (b), are in good agreement with ϕ_{\max} for the second floor, and this result indicates that the incident wave penetrating directly from Tx is stronger than the other reflected waves.

The 2-D angular profiles when θ is 0 and -25 degrees at Rx3 are shown in Fig. 9. Figure 9 indicates that the angular profile changes significantly with θ . Furthermore, it is found that

ϕ_{\max} at $\theta = 0$ degrees is almost in the opposite direction to ϕ_0 while ϕ_{\max} at $\theta = -25$ degrees is in good agreement with ϕ_0 . From this, it is expected that the directivity of the elevation angle will have a large impact on the quality of communications between floors in a two-story house.

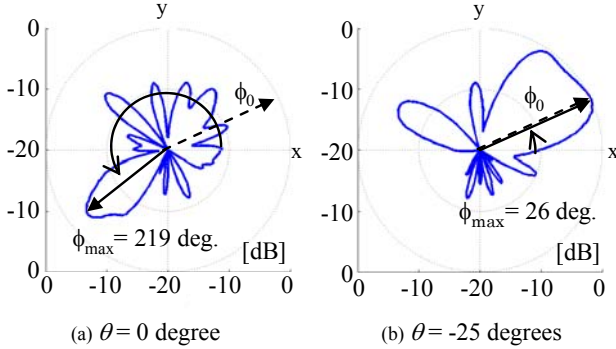

Fig. 9: 2-D angular profiles in the passageway on the second floor.

C. Channel capacity

The channel capacity of a 4-by-4 MIMO can be estimated by using the 3-D angular profiles. A 4-element linear array with a half-wavelength spacing set parallel with the x-axis is assumed. Therefore, 16 iterations of the 3-D angular spectra were measured. The complex received signal \mathbf{h}_{nm} with n-th transmitting and m-th receiving antenna for each elevation angle is then calculated, as follows:

$$\mathbf{h}_{nm}(\theta) = \frac{1}{N_{\max}} \left[\sum_{i=1}^{N_{\max}} \sqrt{Pr_{nm}(i)} \cos\{\alpha(i)\} + j \sum_{i=1}^{N_{\max}} \sqrt{Pr_{nm}(i)} \sin\{\alpha(i)\} \right] \quad (1)$$

where N_{\max} is the number of samples, Pr_{nm} is the received power with n-th transmitting and m-th receiving antenna and α is the phase of the received power. $\mathbf{h}_{nm}(\theta)$ is an element of $\mathbf{H}(\theta)$ that is the channel matrix with N transmitting and M receiving antenna.

The channel capacity $C(\theta)$ for each elevation angle is calculated by using the following expression:

$$C(\theta) = \log_2 \left(\det \left[\mathbf{I} + \frac{Pt}{\sigma^2} \mathbf{H}(\theta) \mathbf{H}^H(\theta) \right] \right) \quad (2)$$

where Pt is the transmit power (0 dBm) and σ^2 is the noise power (-93 dBm). Table 2 shows the channel capacity when θ is 0 and -35 degrees at Rx1 and Rx3.

From Table 2, the channel capacity at Rx3 is considerably smaller than that at Rx1 because the incident waves on the second floor are 10 dB lower than those on the first floor. With respect to Rx3, the capacity that can be achieved for $\theta = -35$ degrees is approximately 1.6 times the value that is achieved at $\theta = 0$ degrees. Therefore, we conclude that the channel capacity of a MIMO can be influenced by the

directivity in the set-up angle, including the direction of the transmit antenna.

TABLE 2: Channel capacity at Rx1 and Rx3.

[bit/s/Hz]	$\theta = 0$ degree	$\theta = 35$ degrees
Rx1 (1 st Floor)	17.1	15.6
Rx3 (2 nd Floor)	3.1	4.9

5. CONCLUSION

In this paper, propagation measurements were conducted at 5GHz in a two-story house containing furniture such as beds, a sofa and tables. First of all, the experiments confirmed a very high time-correlation characteristic in the environment of a residential house. 3-D angular spectra were then measured on the first floor and on the second floor by using a Yagi-Uda antenna. From these results, we concluded that the strongest wave on the first floor travelled in an almost horizontal direction, while the strongest wave on the second floor arrived from a low elevation angle.

Furthermore, we estimated the channel capacities of a 4-by-4 MIMO by using the 3-D angular profile of the incident waves. From this, we found that a 1.6-fold increase in capacity can be achieved by choosing a suitable elevation angle, including the direction of the transmit antenna, compared to the capacity in the horizontal angle.

REFERENCES

- [1] H. Bolcskei, D. Gesbert, and A.J. Paulraj, "On the capacity of OFDM-based multi-antenna systems," *proc. IEEE ICASSP 2000*, pp. 2569-2572, Istanbul, Turkey, Jun. 2000.
- [2] I.E. Telatar, "Capacity of multi antenna Gaussian channel," *European Transaction Commun.*, vol. 1, no.6, pp.585-595, 1999.
- [3] G.J. Foschini and M.J. Gans, "On limits of wireless communications in a fading environment when using multiple antennas," *Wireless Personal Commun.* vol. 6, pp.311-335, 1998.
- [4] A.J. Paulraj, D.A. Gore, R.U. Nabar and H. Bolcskei, "An overview of MIMO communications – a key to gigabit wireless," *proc. of the IEEE*, vol.92, no.2, pp.198-218, Feb. 2004.
- [5] Airgo Networks, Inc. Pioneer in MIMO Wireless Technology, <http://www.airgonetworks.com/>
- [6] K. Sakaguchi, D.N. Dung, C.H.Y. Eugene, K. Araki, H. Iwai, T. Sakata, and K. Ogawa, "Measurements on Area Coverage of 5GHz Band MIMO-OFDM System in Home Environment," *ISAP2005*, vol.1, WA3-1, pp.47-50, Aug. 2005.
- [7] K. Mizutani, K. Sakaguchi, J. Takada, and K. Araki, "Real-Time MIMO Channel Measurement using 5GHz 4-by-4 MIMO-OFDM Hardware," in *Tech. Rep. of IEICE*, WBS2004-117, AP2004-298, RCS2004-385, MoMuC2004-168, MW2004-295, Mar. 2005.