

Reconfigurable Antenna of Frequency and Polarization Diversity for PCS and DMB

Jong-Hyuk Lim and Tae-Yeoul Yun

Department of Electrical and Computer Engineering, Hanyang University

17 Haengdang-dong Seoungdong-gu, Seoul, 133-791, Korea

Email: taeyeoul@hanyang.ac.kr

I. Introduction

In recent years a reconfigurable patch antenna becomes important issue in wireless and satellite communication systems, because it can operate frequency and polarization diversity using PIN-diodes switching [1-5]. The frequency and polarization diversity with single patch and single feed produces a simple structure, small size, and low cost for wireless systems. The polarization diversity is especially to avoid the detrimental fading loss caused by multi-path effect [1]. The reconfigurable antennas are also utilized to realize frequency reuse for doubling the system capability in satellite communication systems [2].

In this paper a new polarization and frequency diversified patch antenna is proposed, using three PIN-diode connections on slot and spur lines. Diodes direct the antenna to work for personal communication systems (PCS) at 1750 MHz or digital multimedia broadcasting (DMB) systems at 2630 MHz. The basic antenna shape consists of a square patch with a spur line, a parasitic patch, and switching PIN diodes. From experimental results, the proposed antenna is verified to show the polarization and frequency diversity and an excellent axial-ratio in circular polarization (CP) performance. Following sections detail the antenna design and theory in section II, simulation and measurement results of all three structures in section III, and finally discussion in section IV.

II. Antenna structure and Theory

A new reconfigurable antenna structure is presented in Fig. 1. A microstrip-fed rectangular patch is printed on a substrate of thickness 1.6 mm and permittivity (ϵ_r) 4.4. Dimensions of the proposed antenna are mentioned in Table 1. As shown in Fig. 1, it has the square patch with three PIN-diodes on the spur line and wide slot. The antenna can be converted into three configurations by switching diodes on and off. When the diode 1 (D_1) and diode 2 (D_2) turn off, the antenna has the spur line of 'L' shape in the main patch with the isolated parasitic patch. Then it is well known as the polarization diversity (LP \Leftrightarrow CP) antenna controlled by the diode 3 (D_3) [3]. When D_3 turns off, the spur line introduces the patch to be right-hand circular polarization (RHCP). Because it has two near-

degenerate orthogonal resonant modes, TM_{10} and TM_{01} , equal amplitudes and 90° phase difference of fields produce. When D_3 turns on with D_1 and D_2 off, the antenna shows the square patch with the parasitic slot line of 'I' shape. It works as the linear polarization (LP) antenna due to similar characteristics of the basic patch antenna of TM_{10} mode. Therefore switching D_3 with D_1 and D_2 off can change the polarization during operating at the same frequency over the DMB band. When all diodes turn on, the antenna has a larger rectangular shape with the wide parasitic slot line and 'T' shape slot. It operates at the lower frequency over PCS band with the linear polarization (LP).

III. Simulation and Measurement Results

Performance of the proposed antenna is simulated to confirm frequency and polarization diversity. Diode-on state is just considered as ideally conducting in the simulation for the simplicity. HFSS (High Frequency Structure Simulator) of Ansoft is used to simulate and optimize the antenna. Results of the input return loss in Fig. 2 show that the realized antenna performs excellent frequency diversity on PCS and DMB bands. Also the measured data are very well agreed with the simulation. Fig. 3 shows a wide 3-dB axial-ratio bandwidth, 100 MHz and CP performance. Radiation patterns for each antenna are simulated with excellent results, as shown in Fig. 4. All measured and simulated data are summarized in Table 2.

IV. Conclusion

In this paper, a novel reconfigurable antenna having three kinds of operation has been presented with single structure and single feed, controlled by switching diodes. The simulation and measurement agreed very well each other. Frequency and polarization diversity was verified, and wide axial-ratio was also obtained in the circular polarization performance. The proposed reconfigurable patch antenna should be useful for PCS and DMB applications.

Acknowledgement

This work was supported by grant no. (R01-2004-000-10461-0) from the Basic Research Program of the Korea Science & Engineering Foundation.

Reference

- [1] Matthias K.fries, Mischa Grani, and Rudiger Vahldieck, "A reconfigurable slot antenna with switchable polarization", *IEEE Microwave Wireless Compon. Lett.*, vol. 13, no.11, pp. 490-492, Nov. 2003.
- [2] Fan Yang and Yahya Rahmat-Samii, "A reconfigurable patch antenna using switchable slots for circular polarization diversity", *IEEE Microwave Wireless Compon. Lett.*, vol. 12, no. 3, pp.96-98, Mar. 2002.
- [3] Tai-Un Jang, Young-Je Sung, and Young-Sik Kim, "Square patch antenna with switchable polarization using spur-line and PIN diode", *The Korea Electromagnetic Engineering Society. Jour.*, vol. 15, no. 12, pp.1178-1183, Dec. 2004.

[4] F. Yang and Y. Rahmat-samii, "Patch antenna with switchable slot (PASS): Dual frequency operation", *Microwave Opt. and Technol. Lett.*, 31, pp. 165-168, Nov. 2001.

[5] F. Yang and Y. Rahmat-samii, "Switch dual-band circularly polarized patch antenna with single feed", *Electron. Lett.*, vol.37, pp.1002-1003, Aug. 2001.

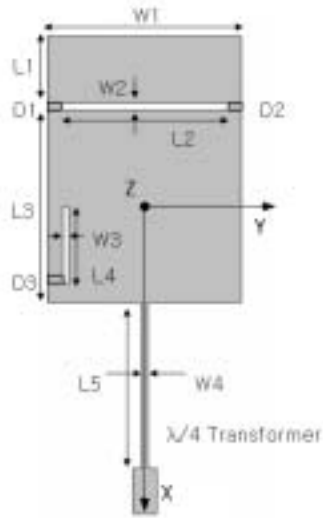
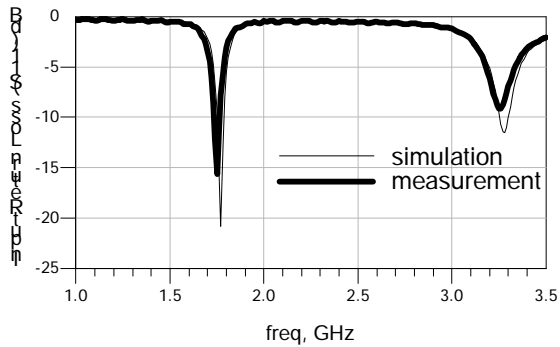

Table 1. Dimensions of the proposed antenna. (unit : mm)

W1	25	L1	8.6	L5	21.5
W2	1	L2	21.6	D1	1.7x1
W3	0.7	L3	25	D2	1.7x1
W4	0.8	L4	10	D3	2x1

Fig. 1 Geometry of the proposed reconfigurable antenna



(a)

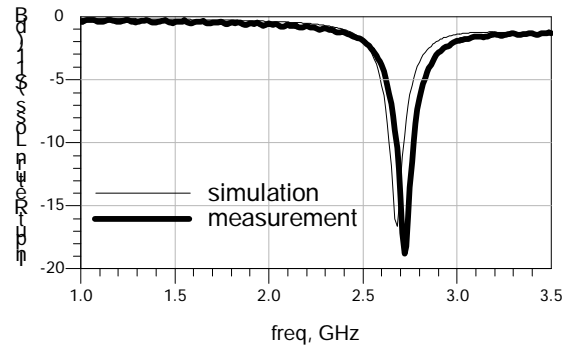

(b)

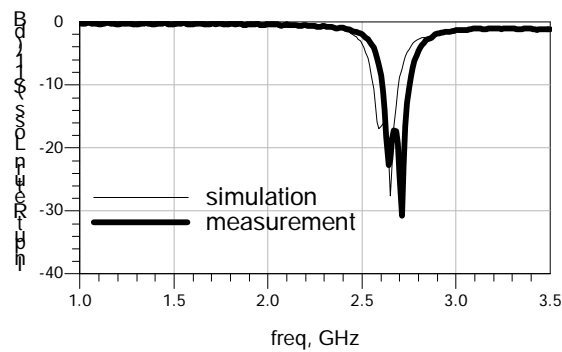

(c)

Fig. 2 Input return loss (a) PCS LP (1750~1780 MHz), (b) DMB LP (2630~2655 MHz), and (c) DMB (RHCP) (2630~2655 MHz)

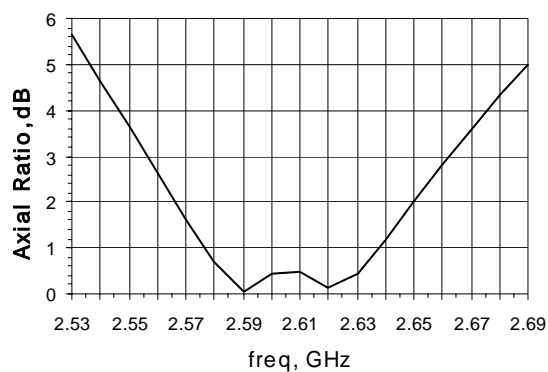

Fig. 3 Simulation of Axial Ratio

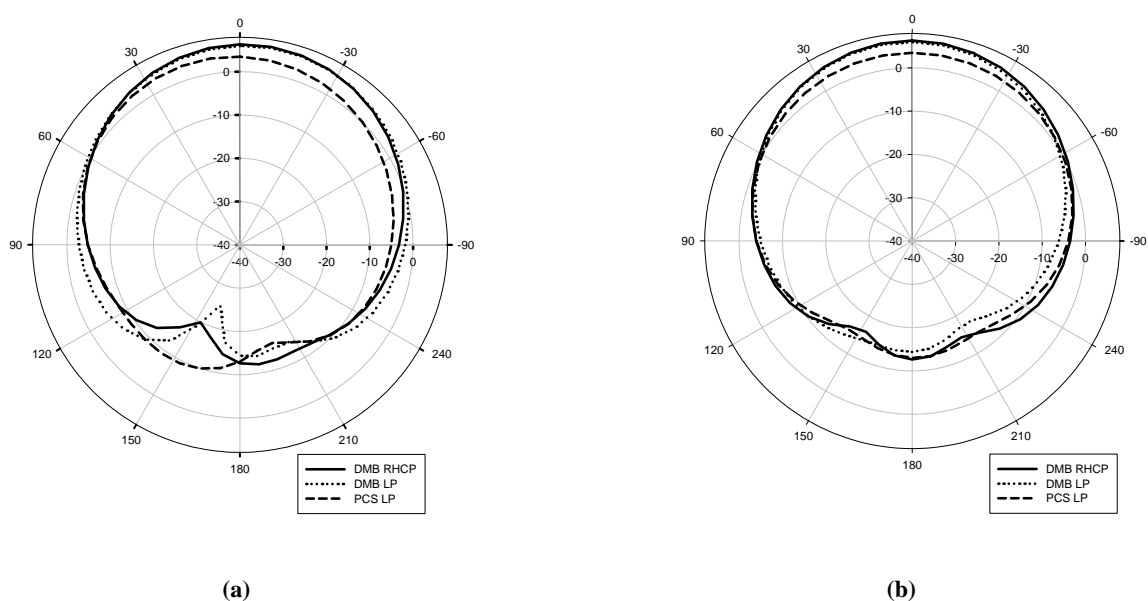

Fig. 4 Radiation patterns (a) x-z plane (b) y-z plane

Table 2. Summary of results

Service	PCS		DMB (gap filler)		DMB (satellite)	
	1750-1780 MHz		2630-2655 MHz		2630-2655 MHz	
Diode State	D1	ON	D1	OFF	D1	OFF
	D2	ON	D2	OFF	D2	OFF
	D3	ON	D3	ON	D3	OFF
Bandwidth	Simulation	Measurement	Simulation	Measurement	Simulation	Measurement
	1750-1780	1735-1765	2630-2710	2670-2770	2560-2700	2605-2750
	30 MHz	30 MHz	80 MHz	100 MHz	140 MHz	145 MHz
Polarization	LP		LP		RHCP	
					3-dB Axial Ratio : 2560-2660 (100MHz)	