

A NEW EM-WAVE ABSORBER USING FUNCTIONAL ELECTROMAGNETIC CELL MATERIAL

Youji Kotsuka, Mitsuhiro Amano

Department of Communications Engineering, Tokai University
 E-mail: ykotsuka@keyaki.cc.u-tokai.ac.jp

Abstract: This paper describes a new functional electromagnetic cell material (EMCM) for EMC use. This novel material is composed of passive or active micro-electronic circuit elements and they are connected with loss or conductive wirings. If it is composed of active circuit elements, this material is able to exhibit a special feature of changeable characteristics of EM-wave absorber. As an example of EMCM, EM-wave absorbers are constructed in this paper. The matching characteristics of the EM-wave absorber are clarified both by experiment and Finite Difference Time Domain (FDTD) analysis. Also, a new communication system using the EMCM as a modulator is presented.

Key words: Material, Circuit, EM-wave absorber.

1. Introduction

A new functional electromagnetic cell material (EMCM) is composed of active or passive micro-electronic circuits essentially in a three-dimensional structure, which is called a unit cell. The unit cells are arranged based on the Bravais lattice in a crystal structure. This new functional material comes from the idea of fusing the crystalline material concept and the one in the living cells which manifests different forms and characters. By introducing these structure, many factors to control this material characteristic occur, for example, how to construct the active or passive micro-electronic circuits, the shape of unit cells, the spatial arrangements of the unit cells and so on. On the bases these functions, the EMCM behaves just as if it were a special material with some permittivity or permeability. Further, when it is embedded in some material, the permittivity or permeability of the material can be changed equivalently. As one EMCM application, EM-wave absorbers are designed in the present paper.

2. Structure

2.1 Fundamental Structure

Fig.1 shows the fundamental unit cell structure of a cubic EMCM. The spherical symbols in Fig. 1 (a) show 2-port circuit elements and the cylindrical symbols in Fig. 2 (b) show 3-port circuit elements, respectively. Wirings with loss or high conductivity are introduced to connect these circuit elements. Normally, for these circuit elements, usual electronic circuit elements such as resistors, capacitors and an inductance are used. If the active circuit elements

such as diodes or transistors are introduced in the cell construction, effective permittivity or permeability become electrically controllable. Fig. 1 (c) shows the combination case of 2-port with 3-port circuit elements.

Due to introducing these structures, many factors can occur to control the EMCM characteristic, for example, how to construct the active or passive micro-electronic circuit, the shape of unit cells, the spatial arrangements of the unit cells and so on. These factors are important to control the characteristics of EMCM.

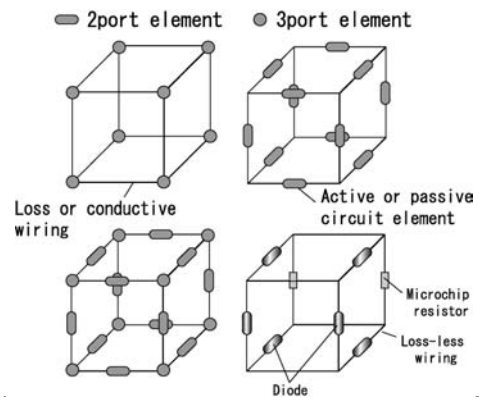

Fig.1 Fundamental unit cell constructions for EMCM

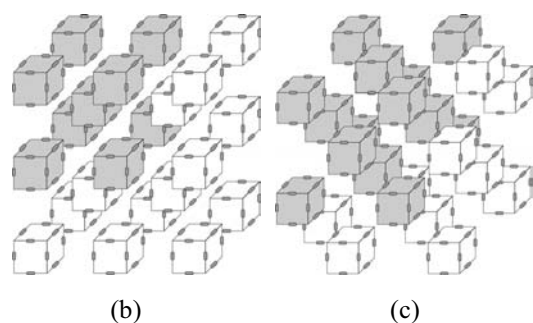
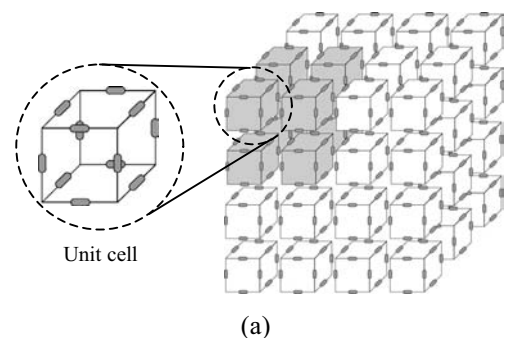

Fig.2 Example of unit cell spatial arrangements.

2B1-4

2.2 A unit cell spatial arrangement

The spatial arrangement method for a unit cell is also important to determine EMC characteristics.

Therefore, the principle of Bravais lattice in crystal material is introduced to put the spatial arrangement of the unit cell in order. Bravais lattice is normally used to describe a crystal structure which consists of atomic arrangements. In the present EMC, unit cell arrangement corresponds to the atomic arrangement in the crystal material. As examples of EMC geometry, three types of EMC are shown in Fig. 2 (a)~(b) based on Bravais lattice arrangement. The EMC in Fig. 2(a) belongs to the simplest Bravais lattice which is called a simple cubic lattice. Fig.2 (b) represents a body-centered cubic lattice, and Fig. 2 (c) is a face-centered cubic lattice.

2.3 An EM-wave absorber construction

As an application example of EMC, an EM-wave absorber was presented. For the design of an EM-wave absorber, a resistive circuit element and wiring with loss are needed. Fig. 1(d) represents an example of absorptive EMC unit cell. This unit cell is composed of diodes, microchip resistors and low loss wiring. This kind of unit cell has the function of changeable matching characteristics. This changeable matching characteristic is obtained by changing the forward bias voltage among diodes.

3. Experimental result

3.1 Model for experiments

To realize an EM-wave absorber based on the EMC structure, the case of the simplest cubic lattice is taken up among the Bravais lattices system. Fig. 3 shows the present structure of EM-absorber. This unit cell belongs to the tetragonal system in the Bravais lattice system when the image of the unit cells against a conductive plate is taken into consideration. Unit cells are comprised of passive and active circuit elements such as microchip resistors and silicon diodes. The microchip resistors contribute to energy absorption and the silicon diodes are mounted to control dynamic characteristics of the EMC.

To check the matching characteristics of the present absorber, fundamental experiments have been conducted. A 39-D coaxial waveguide is used to measure the reflection coefficient by introducing the idea of the image method to simply reproduce the periodical unit cell. That is, the reflection coefficient was measured by mounting a circular unit cell at the end of a shorted coaxial waveguide, keeping a spacing of d . Fig.4 shows the model for the experiment, which is constructed by the unit cells in a circular disk shape for the coaxial waveguide measurement. Fig. 5 (a) represents a part of actual structure of the present unit cells in the ordinary

space. Fig 4 and Fig. 5 (a) are in the equivalent relationship in its structure. A conductive plate is put behind the unit cells, maintaining a spacing of d .

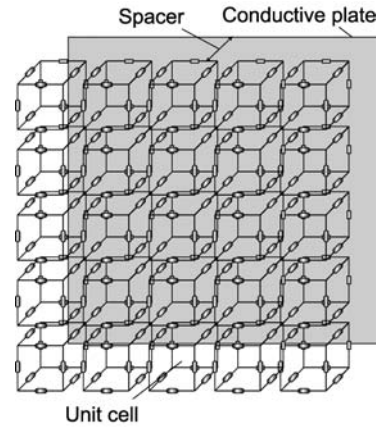

Fig.3 Absorber using EMC

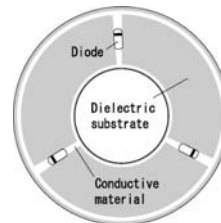

Table. I An absorber size.

a_1	0.7 mm	a_2	1.2 mm
b_1	8.3 mm	b_2	27.9 mm
b_3	4.0 mm	c	1.2 mm
t	1.6 mm	R	100 Ω

Fig.4 Model for experiment

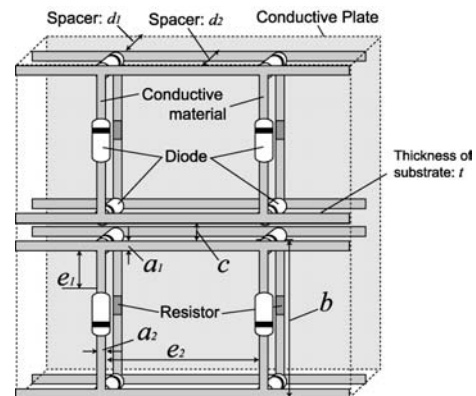

Fig. 5 (a) Model for experiment

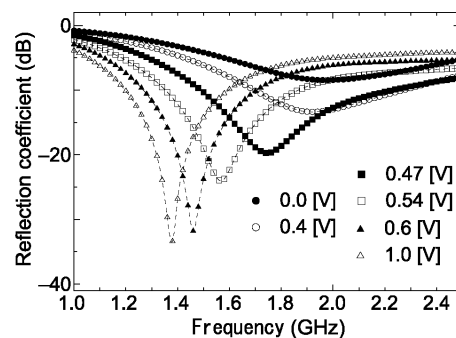

Fig. 5 (b) Matching characteristics of the case in Fig.5 (a)

The structure of present EM-wave absorber is limited to single polarization use only.

That is, the incident electric field is limited to the parallel direction of the front diodes. The unit cell is discontinued to the direction of electric field and continued to the direction of magnetic field. DC bias is provided to each diode.

Fig.5 (b) shows the matching characteristics in Fig.5 (a) when the forward bias voltage of the diode on the unit cell is taken as a parameter, keeping other parameters constant. The matching characteristics are gradually improved and the matching central frequency shifts toward the lower frequency regions as the forward bias voltage is increased.

3.2 Matching characteristics depending on diode arrangement

To examine the diode effect depending on its mounting position on a unit cell, two types of different EMCs are constructed. Fig.6 (a) shows the case of mounting the diodes on the surface of unit cells. Fig.6 (b) shows the present matching characteristics when the forward bias voltage of the diode on the unit cells is taken as a parameter, keeping other parameters constant. The bias voltage per diode is changed from 0.0 V to 1.0 V. These matching characteristics are reflected to the change of matching central frequency and reflection coefficient.

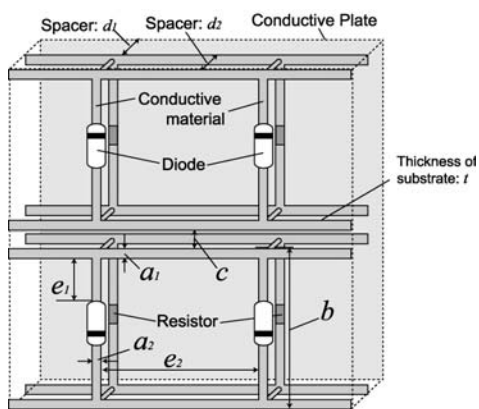

Fig. 6 (a) Model for experiment

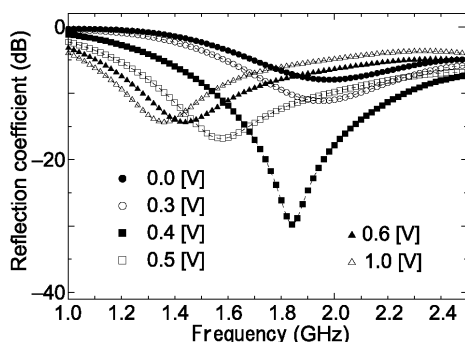

Fig. 6 (b) Matching characteristics of the case in Fig.6 (a)

Fig.7 (a) shows the case of mounting the diodes between both conductive wirings as shown in Fig. 7 (a).

Fig.7 (b) shows the present matching characteristics when the forward bias voltage of the diodes is taken as a parameter, keeping other parameters constant. The bias voltage per a diode is taken from 0.0 V to 1.1 V. When the diodes are mounted between both conductive wirings, it is found that the magnitude of the reflection coefficient is controlled without changing the matching frequency.

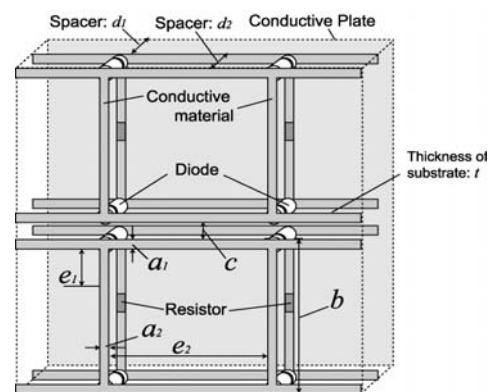

Fig. 7 (a) Model for experiment

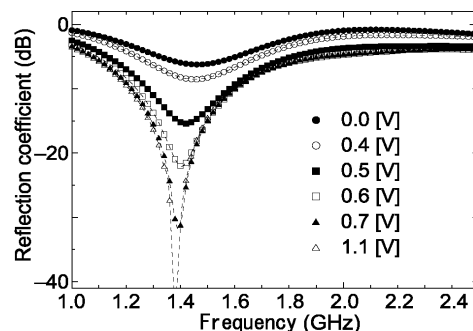

Fig. 7 (b) Matching characteristics of the case in Fig.7 (a)

4. EMC application for communications

4.2 Concept of communication method

As one application of EMC, let us introduce a simple communication system. Fig. 8 (a) shows a new communication system. This system is constructed using a transmitter, a receiver, a directional coupler, an antenna and EMC as a signal modulation function. The EMC acts as a modulator by switching the matching characteristic or the absorption characteristic. The transmitter generates an unmodulated carrier wave and radiates it from the antenna to the EMC. The unmodulated carrier wave propagated to the EMC is modulated at some frequency in proportional to a switching frequency of EMC. The antenna receives the modulated wave from the EMC. The directional coupler in Fig 8 (a) works to divides the unmodulated carrier wave and the modulated wave.

2B1-4

Empirical investigation of the new communication system has been conducted. Fig. 9 shows experimental configuration. To check the signal being modulated by EMCM, a coaxial waveguide is used in place of spatial measurement based on antenna radiation.

By measuring the amplitude modulated signal, the validity of the present system is verified. Fig. 10 (a) shows the experimental wave forms on an oscilloscope display when an unmodulated carrier wave is radiated to the EMCM. The upper wave form represents the one radiated from transmitter to the EMCM and the lower wave form exhibits a reflected wave form from the EMCM. Fig. 10 (b) shows the case of switching the absorption of the EMCM using EMCM in Fig.7 (a). The present wave is modulated by a square wave at 1.0[kHz]. The structure of the EMCM is the same as in Fig.7 (a) and the carrier wave frequency is 1.4 [GHz] in Fig. 10 (a) and (b). Based on these experiments, it is concluded that the EMCM is available as a kind of modulator for a new communication system.

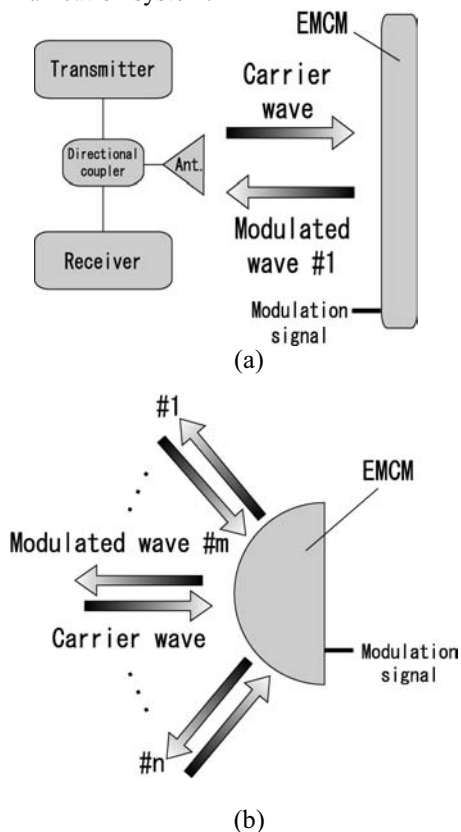

Fig.8 Application of EMCM for communications.

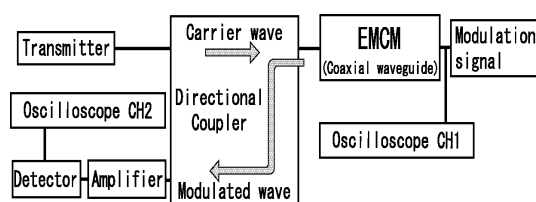

Fig.9 Construction of an experimental equipment

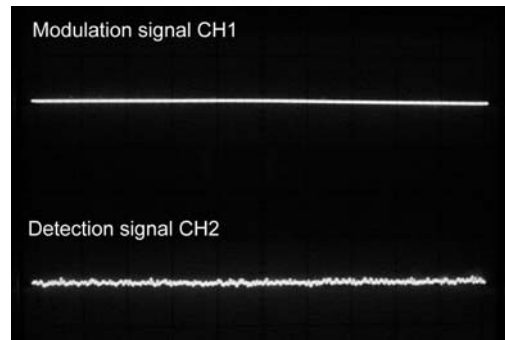

Fig.10(a) Unmodulated signal.

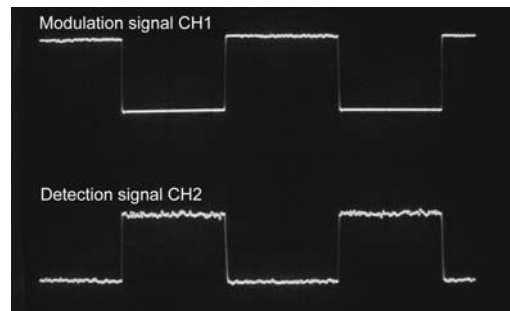

Fig.10(b) Modulated signal.

This kind of communication system will be also useful to constructed with a simple and low cost system. When this communication system will be constructed by a 3 dimensional EMCM, the communication system with the function of multi modulated wave radiation can be constructed as shown in Fig.8 (b).

5. Conclusion

A new functional electromagnetic cell material (EMCM) for EMC use was proposed based on a new concept of fusing the crystal material concept and the one in the living cells which manifests different forms and characters. The EMCM is composed of active or passive micro-electronic circuits essentially in a three-dimensional structure, which is called a unit cell. The unit cells are arranged based on the Bravais lattice in a crystal structure. Results obtained are as follows.

- (1) It is clarified that EM-wave absorber can be constructed using the EMCM.
- (2) The EM-wave absorber has a special feature of realizing electrical changeable matching characteristics.
- (3) As one of application of the EMCM, a simple communication system was constructed using the EMCM as a modulator.

References

- [1] M. E. Della-Sera, F. C. Smith "Design and application of an active microwave absorbent material," Proc 20th Annu Meet Symp Antenna Meas Tech Assoc 1998, pp. 321-323, 1998.