

# MIMO-SDMA configuration using directivity and polarization control for multi-rate broadband wireless systems

Kentaro NISHIMORI, Yasushi TAKATORI, Riichi KUDO,  
 Nobuhiko TACHIKAWA, Kouichi TSUNEKAWA  
 NTT Network Innovation Laboratories, NTT Corporation  
 1-1, Hikarino-oka, Yokosuka, Kanagawa, 239-0847  
 E-mail : nishimori@m.ieice.org

## 1. Introduction

Due to the recent popularity of mobile phones and wireless LAN systems, high data rates, a high level of reliability, and high channel capacity have become important requirements for wireless communication systems [1]. Moreover, recent wireless communications comprise not only voice, but also data transmissions (i.e., Internet download). Thus, multi-rate broadband systems that deal with both voice and data transmissions at 10 to 100 Mbps are required for future wireless communication systems.

To achieve such broadband communication systems, not only high spectrum efficiency, but also spectrum resource management according to the transmission rate of terminal stations (TSs) are required. Space Division Multiple Access (SDMA) and Space Division Duplexing (SDM) have attracted much attention as technologies to improve the spectrum efficiency [2][3]. In addition, SDM (MIMO)-SDMA, which combines these technologies, was proposed to obtain the required higher spectrum efficiency [4]. However, when the number of TSs increases, the transmission quality is severely degraded if conventional SDMA is used [5]. A method that can achieve channel assignment taking into consideration spectrum resource management according to the transmission rate of TSs has not yet been proposed in SDMA and SDM-SDMA systems. This paper proposes a new MIMO-SDMA configuration using dual polarization antennas at the BS and TSs that can achieve high spectrum efficiency while achieving high multi-rate data transmission. Based on the transmission speed required by the TSs and the spatial correlation between the TSs, the BS in the proposed configuration determines the combinations and the number of antennas that the TSs use to transmit. The proposed scheme can also employ space resource management according to the QoS (Quality of Service) of the TS. Moreover, the effectiveness of the proposed configuration is shown by computer simulation when broadband OFDM transmission in an indoor environment is assumed.

## 2. Proposed configuration

Figure 1 shows the concept of the proposed MIMO-SDMA. As shown in this figure, since a dual polarized antenna is used at the BS and TSs, SDMA can be achieved when terminals are close to each other by using this configuration. Moreover, in the proposed MIMO-SDMA configuration, the BS determines the transmission antennas for each terminal based on the transmission speed required by each terminal and the interference between the TSs. As shown in Fig. 1, if TS#1 requires a high data transmission rate and TSs other than TS#1 (i.e., TSs #2, #3, and #4) require a low transmission rate, the BS instructs TS#1 to transmit signals using both vertically polarized (V.-pol.) and horizontally polarized (H.-pol) antennas to achieve the SDM scheme. The BS also determines the combination and the number of transmission antennas for TSs #2, #3, and #4 to avoid interference among all the terminals. In the case of Fig.

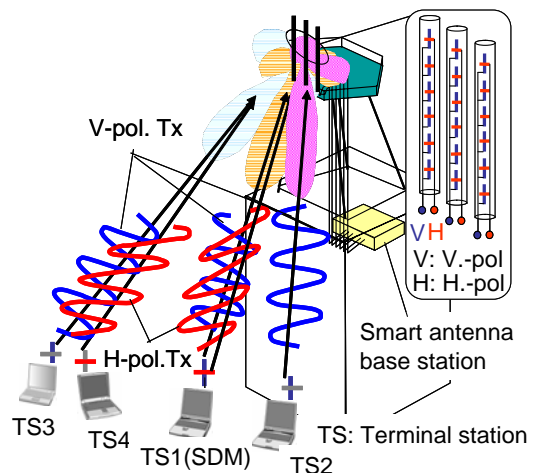

Fig.1 Concept of proposed MIMO-SDMA

1, since there is separation between the angles of arrival (AOAs) for TSs #2 and #3, antennas that have the same polarization are assigned to TSs #2 and #3. On the other hand, antennas that have different polarizations (V-pol. and H-pol.) are assigned to TSs #3 and #4 because there is very little separation between the AOAs of these two TSs.

Figure 2 shows the proposed BS and TS configuration. Figure 2

shows that the TS has a branch selection part to determine the combinations and number of antennas that the TS uses to transmit. The BS also has a calculation part in which the spatial correlation [6] is calculated between the TSs, and the Minimum Mean Square Error (MMSE) algorithm is employed using the ports of dual polarization antennas in the SDMA processor in Fig. 2. TS transmits signals using a branch selection part by the feedback information judged at the BS.

Figure 3 shows the flowchart to determine the combinations and the number of transmission antennas for the terminals. First, the BS measures the transmission speed required by each TS and selects the terminals that will be used in the SDM scheme according to this transmission speed. This scheme is called Step A in Fig. 3 and TS#1 is selected in Fig. 1. The spatial correlations are measured among the terminals that use the SDM scheme and the terminals that are not selected in Step A. It is known that measuring the spatial correlation is an effective way to know whether SDMA can be achieved [6]. In this measurement, if the spatial correlation values are lower than the threshold values, these antennas are selected as candidates for the transmission antennas. Threshold level  $\beta$  is set to 0.9 in this paper. This scheme is called Step B in Fig. 3. Finally, the spatial correlation among the terminals, which is selected in Step B (TSs #2, #3, and #4 in Fig. 1), is measured again. In this scheme, the combination and number of antennas that can be used while avoiding interference among the terminals is determined. This scheme is called Step C in Fig. 3. Therefore, since the proposed MIMO-SDMA can discriminate the users while achieving the transmission speed required by the TSs, the base station can realize the space resource management according to the QoS of the TSs.

### 3. Effectiveness of propose configuration

#### 3.1. Simulation Conditions

To clarify the effectiveness of the proposed configuration, we compared the Bit Error Rate (BER) characteristics between the proposed and conventional SDMA in an indoor environment when a wideband Orthogonal Frequency Division Multiplexing (OFDM) signal transmission is employed. The

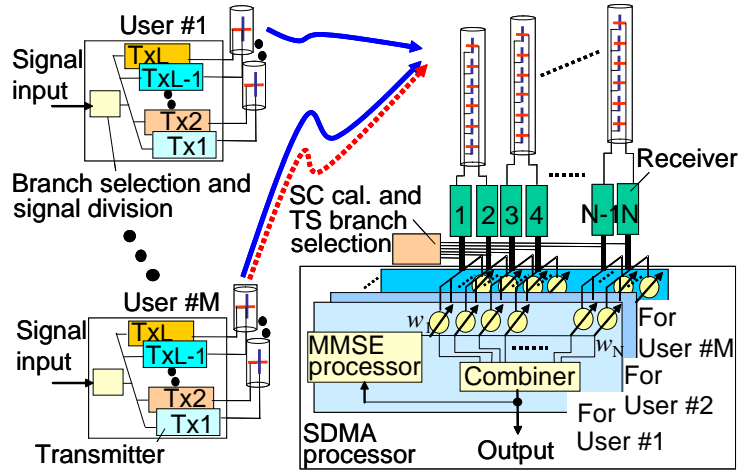

Fig.2 proposed BS and TS configuration

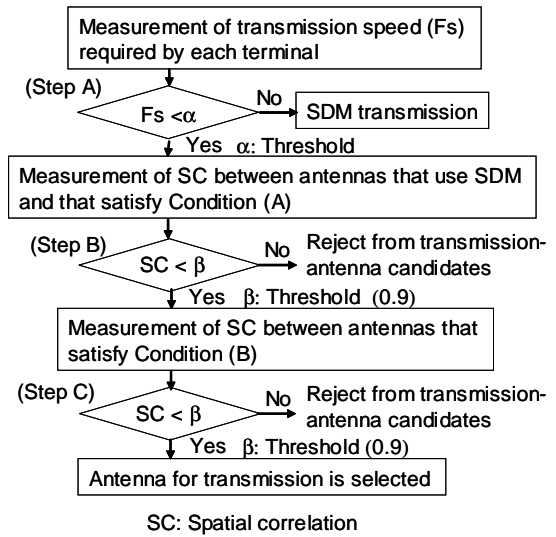

Fig. 3 Flowchart of proposed scheme

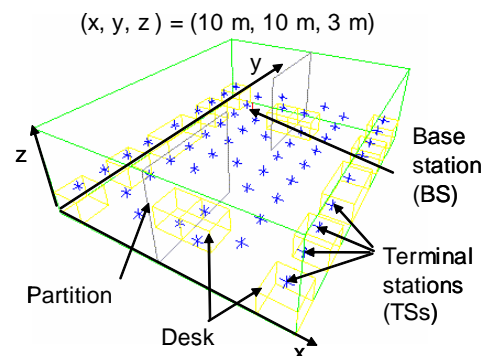

Fig. 4 Model using the ray-tracing simulation

simulation conditions are described in the following. Figure 4 shows the room used for the evaluation. In Fig. 4, We assume that the walls, partitions, ceiling, and floor are all constructed of metal. There are 14 desks and 2 partitions in this room. The height of the desks is 0.9 m. The base station is located in the middle of the room ( $x = 5$  m,  $y = 5$  m). Fifty TSs are indicated in Fig. 4. The height of the BS and TSs are 2.5 and 0.9 m, respectively. The half power beam widths of the vertical and horizontal planes of the antennas are 360 and 90, respectively.

The multi-path signals with the vertical and horizontal polarization are obtained by using the ray-tracing method. The numbers of reflections and diffractions are 20 and 1 time, respectively. In this simulation, the total number of rays considered here is about 1,000 and the delay spread is almost from 90 to 100 ns.

Table 1 gives the combinations between the BS and TSs. As shown in the table, the number of branches at the BS is four. The number of branches at a TS is two when the SDM scheme is applied (Configs. 2 and 4 in Table 1). Different signals from the two branches are transmitted using omnidirectional antennas in the SDM configurations. We evaluated vertical-only and dual (vertical and horizontal) as the polarization of the BS and TSs. Configuration 3 in Table 1 is the configuration that was proposed in Ref. [5]. The element spacing of the array is 0.5 wavelengths at both the BS and TSs. The array antenna is placed across the x-axis in Fig. 4. The trial number changing the terminal's location is 1,000.

Figure 5 shows the channel assignment for the conventional SDMA and SDM-SDMA. As shown in the figure, since SDM-SDMA can transmit double the amount of data information as SDMA can in the same period, we assume that SDM-SDMA can transmit the signals in half the time of SDMA. The frequency is 5.0 GHz, and the OFDM-16QAM signal is transmitted by the TSs. The number of sub-carriers for the OFDM signals is 50 and the length of the guard interval is 16 samples. The input CNR (Carrier to Noise power Ratio) is 30 dB. The common weights for all sub-carriers of OFDM signals are used in MMSE algorithm. The average value of the spatial correlations for all sub-carriers is used in the proposed scheme.

### 3.2 BER Improvement in Conventional Configurations

Figure 6 shows the average BER characteristics versus the transmission rate. The figure shows that the transmission quality is severely degraded when the transmission speed exceeds 10 to 15 Mbps in the case of Configs. 1 and 2. However, the SDMA configuration that uses dual polarization at the BS and TSs (Config. 3) improves the BER characteristics for Configs. 1 and 2, and the BER becomes large when the transmission rate exceeds 25 Mbps. On the other hand, the proposed MIMO-SDMA configuration can achieve the BER of less than  $10^{-4}$  at the transmission speed of 40 Mbps.

Moreover, the proposed configuration can transmit the signal at 2.8 and 1.5 times faster than that of Configs. 1 and 3 at the BER of  $10^{-4}$ , respectively.

### 3.3 Transmission Quality in Multi-rate Transmission

The proposed MIMO-SDMA is effective in multi-rate transmission because the number of transmission antennas is determined according to the transmission speed in the proposed scheme. In this section, the BER performance of the proposed configuration is evaluated for multi-rate data transmission. Figure 7 shows the channel assignment for the multi-rate data transmission. The number of TSs in this

Table 1 BS and TS Combinations  
(BS: Base station, TS: Terminal station)

	Terminal station	Base station (4 branches)
Config. 1 (SDMA)	V. pol. 1 branch	V. pol.
Config. 2 (SDM-SDMA)	V. pol. 2 branches	V. pol.
Config. 3 (VH-SDMA)	V. or H. pol. 1 branch-Tx	V. and H. pol.
Config. 4 (Proposed)	V. and H. pol.	V. and H. pol.

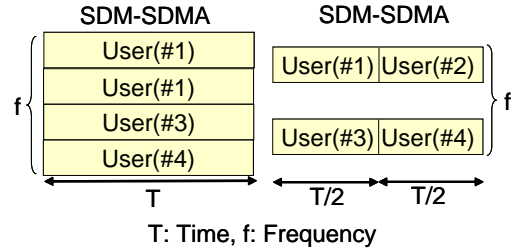

Figure 5 channel assignment

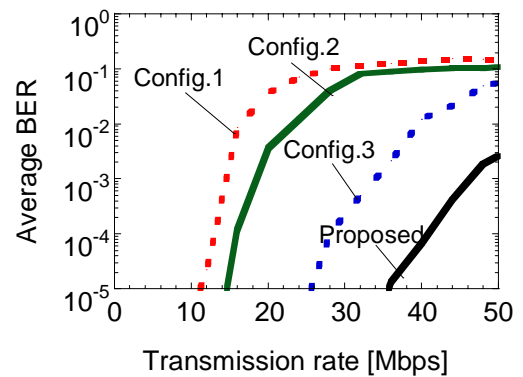

Fig. 6 BER vs. transmission rate

simulation is four and the transmission speed among the four TSs is assumed to be 4:2:1:1. In this simulation, TS#1 is required by the SDM scheme to satisfy the transmission speed. In addition, the number of branches for TSs #2, #3, and #4 is one in the conventional SDMA.

Figure 8 shows the average BER characteristics versus the transmission rate for TS#1. The figure shows that the transmission quality is severely degraded when the transmission speed exceeds 25 Mbps for SDM-SDMA. However, the SDMA configuration that uses dual polarization at the BS and TS (VH-SDM-SDMA) improves the BER characteristics for SDM-SDMA, and the BER becomes large when the transmission rate exceeds 45 Mbps. On the other hand, the proposed MIMO-SDMA configuration achieves a BER of less than  $10^{-4}$  at the transmission speed of 70 Mbps. The proposed configuration can transmit the signal at 2.4 and 1.6 times faster than that of SDM-SDMA and VH-SDM-SDMA at the BER of  $10^{-4}$ , respectively.

Figure 9 shows the average BER for each TS when the transmission speed is 72 Mbps for TS #1. In this case, the transmission speed for TSs #1, #2, and #4 is 36, 18 and 18 Mbps, respectively. As this figure shows, the BER for #TS 1 largely degraded when the SDM-SDMA and VH-SDM-SDMA is employed because On the other hand, the propose MIMO-SDMA can achieve the BER of  $2 \times 10^{-4}$  for #TS1. There is a greater than two and one order of magnitude improvement in the BER performance for SDM-SDMA and VH-SDM-SDMA, respectively, by applying the proposed MIMO-SDMA.

#### 4. Conclusion

This paper proposed a new MIMO-SDMA configuration using dual polarization antennas at both the BS and TSs that can achieve high spectrum efficiency while realizing the broadband multi-rate transmission. The proposed configuration can realize the space resource management by determining the combinations and the number of antennas that the TSs use to transmit according to the transmission rate of the TSs and the correlation between the TSs. Moreover, based on the computer simulation results, the proposed MIMO-SDMA configuration can transmit a signal at 2.4 to 2.8 times faster than that using the conventional SDMA when the multi-rate data transmission is employed.

#### Acknowledgment

The authors thank Dr. Masahiro Umehira of Nippon Telegraph and Telephone Corporation (NTT) for his constant encouragement.

#### References

- [1] S. Ohmori, et al., IEEE Commun. Mag., vol. 38, pp. 134-142, no. 12, Dec. 2000.
- [2] K. Cho and T. Hori, Proc. of ISAP2000, pp.1485-1488, August, 2000.
- [3] G.J. Foschini, et al., IEEE J-SAC, vol. 17, No. 11, pp. 1841-1852, Nov. 1999.
- [4] A. Paulraj et al., "Introduction to Space-Time Wireless Communications," Cambridge University Press, 2003.
- [5] K. Komiya, K. Nishimori, K. Cho, and T. Hori, Proc. of VTC 2001-Fall, vol.3, pp.1447 -1451, Oct. 2001.
- [6] T. Ohgane, Y. Ogawa, and K. Itoh, Proc. of VTC 1997, vol.2, pp.725-729, May, 1997.

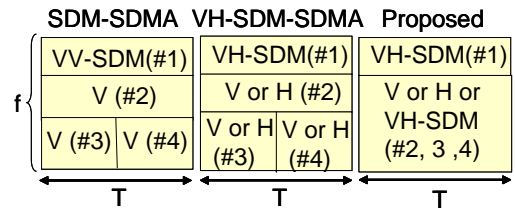

Fig. 7 channel assignment for evaluating multi-rate users

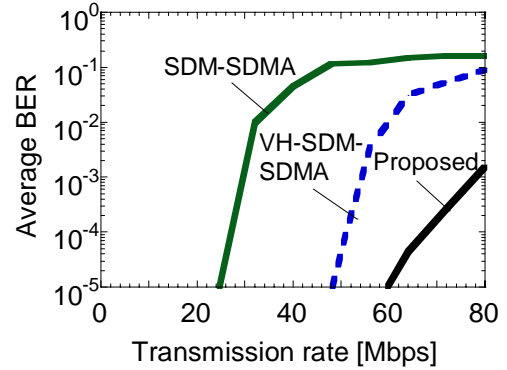

Fig. 8 BER vs. transmission rate (Multirate user TS#1)

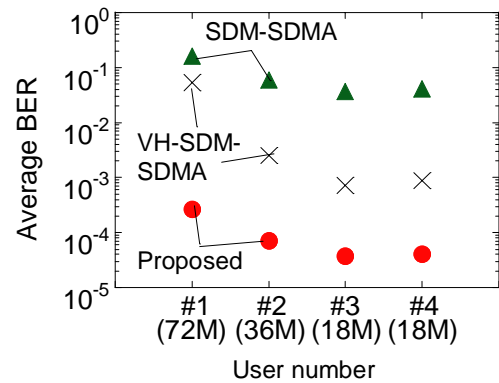

Fig. 9 BER vs. user number