

# FAR FIELD ANTENNA MEASUREMENT SYSTEM FOR ADVANCED CAR ANTENNA DEVELOPMENT

Rainer Kronberger\*, Heinz Lindenmeier, Leopold Reiter, Jochen Hopf  
 Institute for High Frequency Techniques  
 University of the Bundeswehr Munich, 85577 Neubiberg, Germany  
 \*Fuba Automotive GmbH, 31162 Bad Salzdetfurth, Germany  
 Rainer.Kronberger@UniBw-Muenchen.de

**Abstract**

This paper presents an antenna measurement system for most types of car antennas. An outdoor far field antenna range with a radome for weather protection has been installed. Using a network analyzer in sweep frequency mode broadband car antenna measurements can be performed. This provides the basis for fast and effective development of highly complex FM or TV antenna diversity systems.

**1. Introduction**

Within the last years antenna measurement systems have been changed remarkably. The previous main rf components of a far-field antenna measurement system, the receiver and the transmitter have usually been replaced by a single network analyzer. Beside conventional measurement on single frequencies the sweep mode of the network analyzer allows rapid and precise antenna measurement over a wide bandwidth which results in a significant factor in time saving. Another advantageous feature of a (vector)-network analyzer is the possibility to measure the complex radiation data (magnitude and phase) of an antenna, which are the basics for near-field antenna scanning. Nevertheless great care has to be taken on the design of the measurement range to achieve plane wave conditions at the location of the test antenna (i.e. compact ranges, anechoic chambers). Especially with large antennas or antennas on large objects, i. e. vehicles, and at frequencies starting from 45 MHz, measurements usually have to be performed in outdoor far-field antenna ranges.

For a long time typical car antenna measurement was performed by driving in circles with the car and

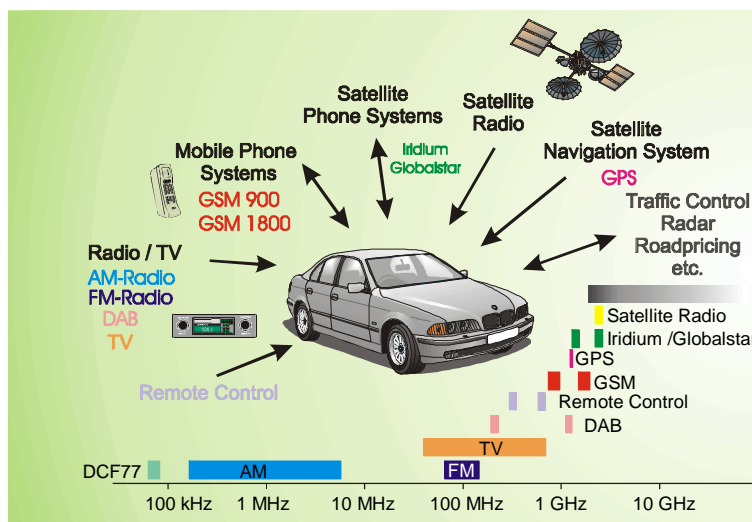

Fig. 1: Communication services in a modern car

by measuring the received signal levels of broadcasting stations. Thus reproducible measurements of the same results often failed due to Rayleigh distribution of the received signals.

With modern cars a variety of antennas for different communication services in the frequency range between 100 kHz and 2 GHz are used (fig. 1). Nowadays modern car antennas for terrestrial FM, TV and cellular phone services are mostly designed as broadband or multiband antennas. Thus only with advanced and sophisticated measurement techniques, a rapid, precise and effective development of such highly complex antenna systems is possible.

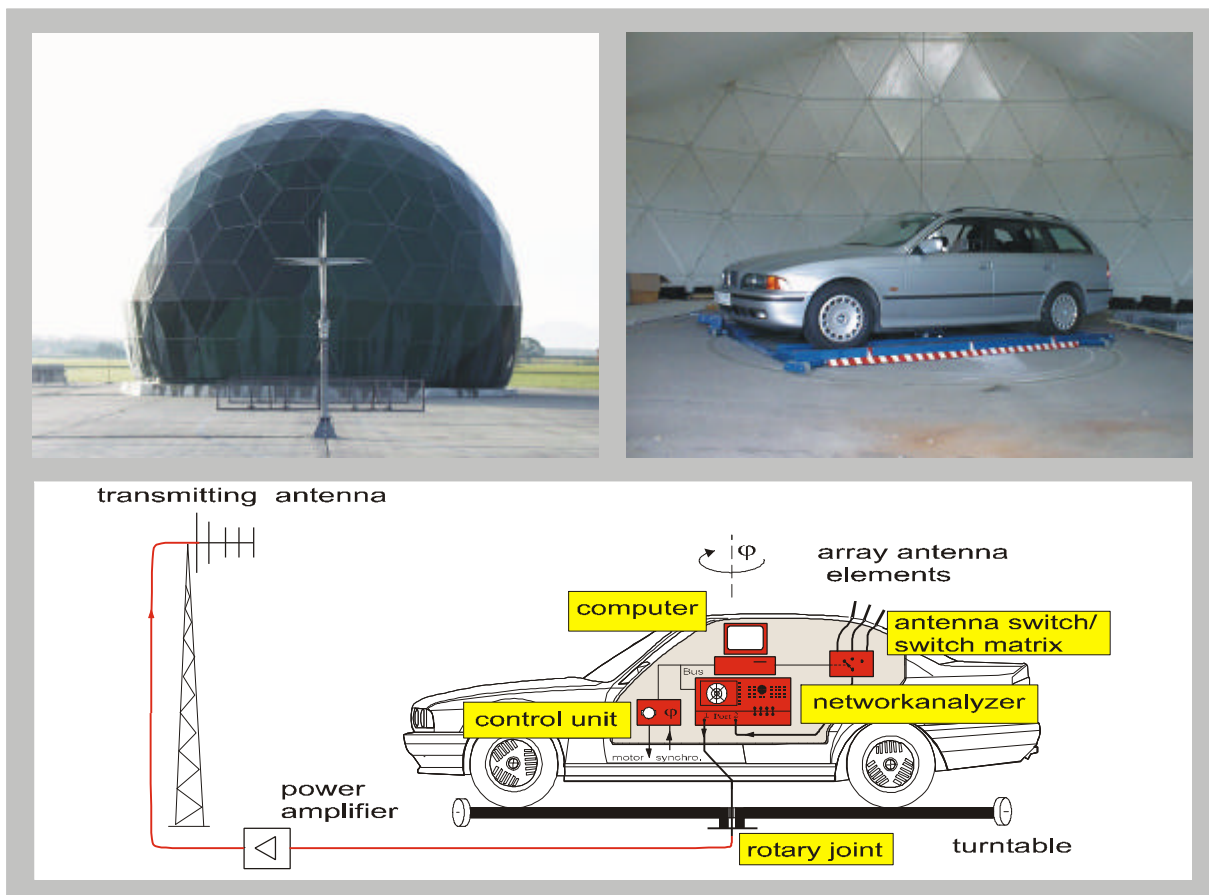

Fig. 2: Antenna range and measurement principle

## 2. Car antenna measurement

Modern car antennas for terrestrial FM and TV reception are designed as conformal on glass antenna structures on the windshield or on the backlite. Usually those structures operate as broadband antennas and are highly coupled with the environment, i. e. the vehicle and the other antenna structures. This often results in multi resonant and frequency dependent radiation behavior of the antennas. Thus it is necessary to employ sweep frequency techniques in order to obtain complete and continuous information of antenna radiation over the entire frequency range.

Fig. 2 shows the antenna range and measurement principle which has been applied for car antenna measurement. The car with the test antenna on it, is placed on a ground level turntable. The complete measurement equipment which consists of a network analyzer, a control unit for motion control of the turntable and a portable computer for measurement control and data acquisition, is inside the car. The turntable is driven by a dc motor. RF-signal, control signals and AC/DC power are passed through a rotary joint and over slip rings.

Due to the dimensions of the car the required far field distance should be approx. 50 – 100 m in the frequency range 50 – 1000 MHz. Anechoic chambers of this size for complete indoor measurement are very expensive. Thus only the measurement object itself is placed inside a radome. This allows measurements to be almost independent from weather conditions.

With terrestrial communication services usually linearly polarized car antennas are required, either horizontally or vertically. Therefore a crossed log-periodic broadband antenna as far field antenna has been installed. In addition a switch matrix and 90 degree hybrids at the far field antenna are used to generate 45°-slanted polarizations as well. Cross polarization at the location of the test antenna is better than 25 dB over the entire frequency range.

The ground area of the test range consists of concrete which almost agrees with regular ground conditions. To avoid ground reflections which might interfere with the direct wave from the far field antenna, additional metallic diffraction fences have been installed. Field probing on the turntable in all used frequency ranges confirmed an almost homogeneous region of the incident waves with a ripple of +/- 1.5 dB maximum over the entire frequency range and for both polarizations.

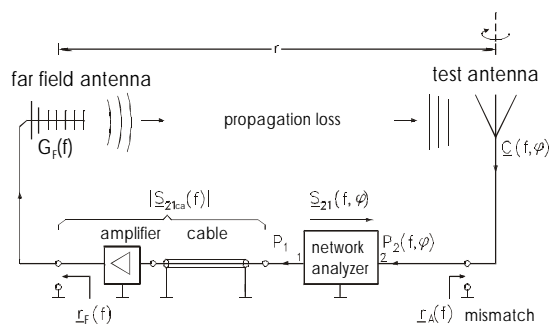

Antenna gain function	$g(f, \varphi) / \text{dB} =$
measured data	$20 \log  S_{21}(f, \varphi) $
cable/ampl. correction	$- 20 \log  S_{21c a}(f) $
propagation loss	$+ 20 \log (4\pi r / \lambda)$
farfield antenna gain	$- 10 \log G_F(f)$
far field antenna mismatch	$-10 \log M_F(f)$
test antenna mismatch	$- 10 \log M_A(f)$ (1)

Fig. 3: Frequency dependent components of the measurement system

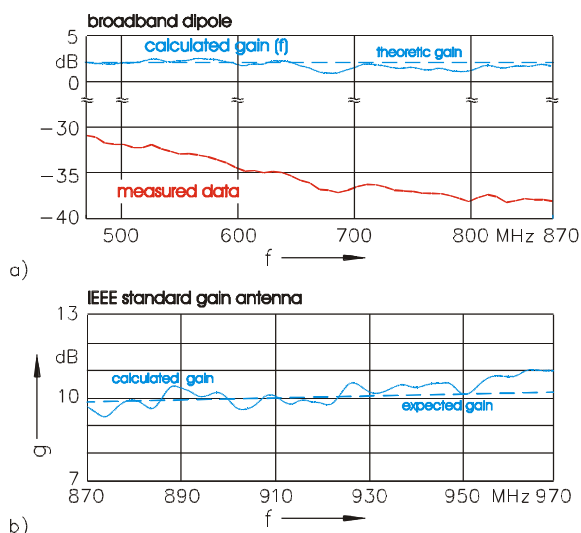

Fig. 4: Measured data and corrected gain function of a broadband dipol antenna (a), gain of a IEEE standard gain antenna (b) (without radome)

To compensate for frequency dependent cable and propagation losses of the measurement system, an additional power amplifier is inserted in the output path of the network analyzer (fig. 3). The amplification is chosen to achieve sufficient received signal level at port 2 of the network analyzer for optimum dynamic range of the measurement system.

Considering cable and propagation losses of the system, antenna mismatch and amplifier gain, correction factors can be defined which allow isotropic antenna gain measurement (eqn. 1). Fig. 4a shows the measured raw data and the evaluated antenna gain function with this method of a broadband UHF dipole antenna and fig. 4b shows the gain function of standard gain antenna [1] in the GSM900 frequency range. In comparison with the expected gain values of the antennas this proves the excellent measurement accuracy of the antenna range.

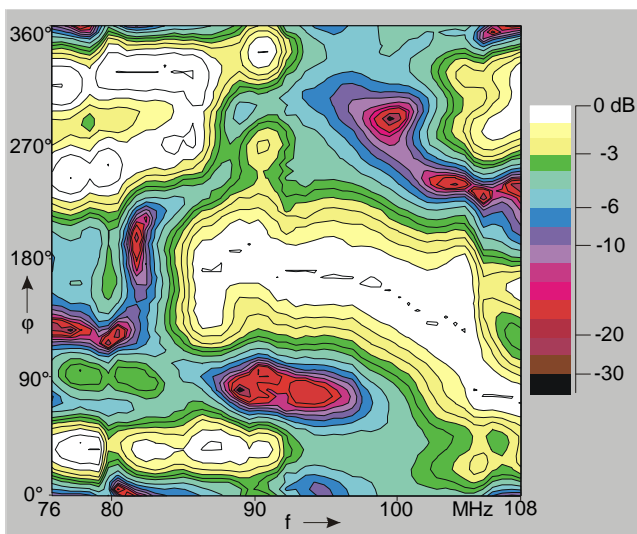

Fig. 5: Representation of frequency dependence of the antenna pattern as contour plot

### 3. Data representation

With sweep frequency techniques each azimuth turn provides an enormous amount of measured data. In addition to standard online display of antenna pattern, impedance and mean gain of the antenna, a colored contour plot for overall data representation has been created. This shows very clearly frequency dependence of the antenna pattern which particularly changes significantly with car antennas, as shown in fig. 5 with the example of a FM-antenna in the rear window of a car. The azimuth values are normalized to the maximum value of each measured frequency point. This form of data presentation is also very helpful for evaluation of antenna diversity systems.

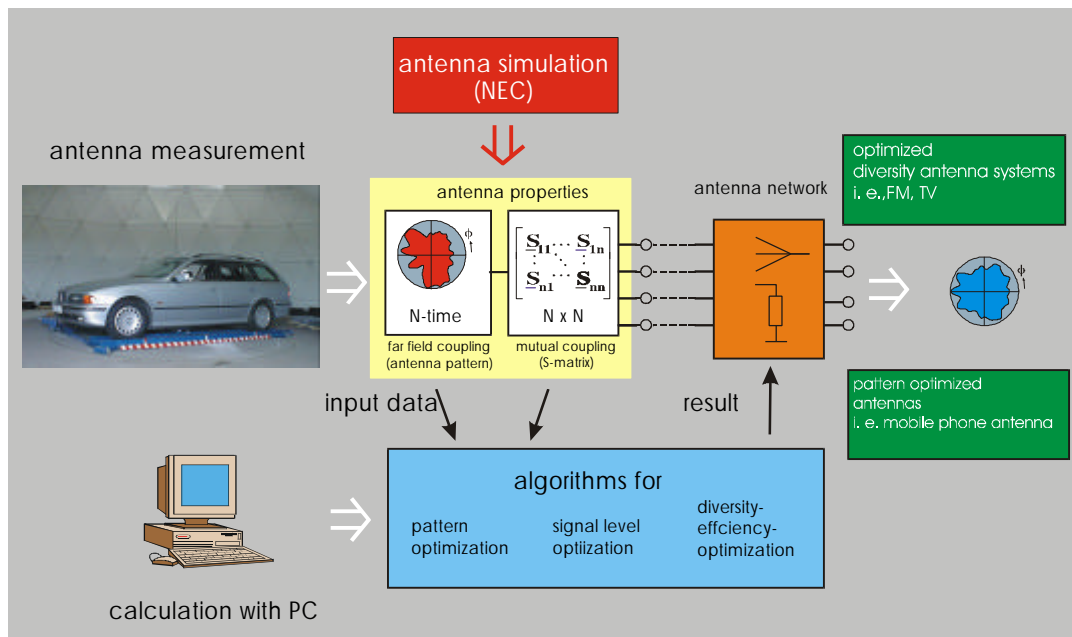

Fig. 6: Principle of car antenna development

#### 4. Development of antenna diversity systems

The above shown measurement system represents the basis for advanced antenna development. With FM or TV antenna diversity systems in one car window it is of great importance to determine the appropriate locations of antenna terminals with respect to optimum signal level and decorrelation of the various antenna signals. Complete measurements of the individual 4 antennas of a diversity systems for FM or TV with the above described method are performed in approximately 30 minutes.

For development and optimization of such systems a combined method of highly accurate measurement and mathematical optimization has been applied [2]. The electrical characteristics of the arrangement of  $n$  antennas on the car and an additional test antenna with a given polarization in the far field of the car is described as  $(n+1)$ -port, by using scattering parameters (fig. 6). By means of pattern measurement of each antenna in its position on the car in amplitude and phase and measurement of the mutual coupling between them the complete equation system for the arrangement can be given.

By means of computer aid each individual antenna of the system can be optimized with respect to maximum signal level, maximum pattern decorrelation and maximum diversity effectiveness for optimum system performance [3]. Complete car antenna development is supported by antenna simulation tools, i. e. NEC etc.. In fig. 7 the switching behavior of a TV-picture diversity system in the entire UHF frequency range is illustrated. This has been completely evaluated from measured antenna data of each individual antenna.

Due to the almost uniform selection of each of the four antennas for a full turn of the car in the azimuth plane a highly effective diversity performance could be realized.

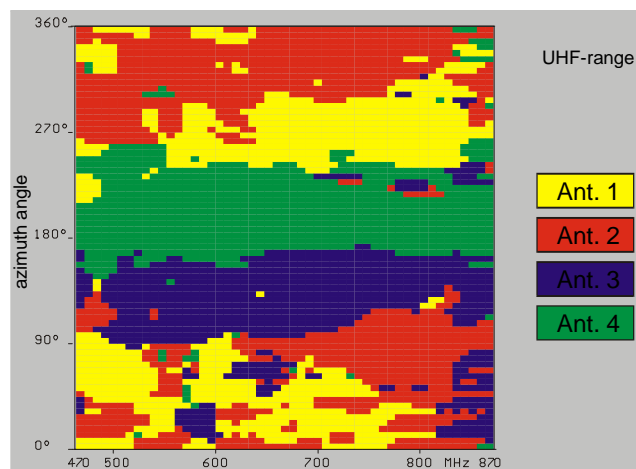

Fig. 7: Azimuthal antenna selection of a 4 antenna TV picture diversity system in the UHF range.

#### 5. References

- [1] IEEE Standard 149-1979: Test procedures for Antennas. IEEE, New York, 1979.
- [2] Kronberger, Lindenmeier, Reiter, Hopf: Array antenna principle applied to modern car antennas. IEEE Antennas and Propagation Symposium, Atlanta, USA, 1998.
- [3] Lindenmeier, Hopf, Reiter, Kronberger: Optimization of the antenna-diversity-effectiveness of complex FM-car-antenna systems. IEEE Antennas and Propagation Symposium, Orlando, USA, 1999.