

## FLEXIBLE MICROSTRIP APPLICATOR FOR MEDICAL APPLICATION

Yoshio Nikawa\*, Shinsaku Mori\*\* and Fumiaki Okada\*

\*Department of Electrical Engineering,  
The National Defense Academy  
1-10-20 Hashirimizu, Yokosuka 239 Japan

\*\*Department of Electrical Engineering,  
Faculty of Science and Technology,  
Keio University  
3-14-1 Hiyoshi, Kouhoku, Yokohama 223 Japan

### ABSTRACT

A new microstrip patch applicator is proposed for medical application such as hyperthermia treatment of cancer. The applicator is small, light in weight and flexible. The dielectric part of the applicator consists of silicone rubber and water. A circulation of cooling water in the dielectric part can cool the applicator and therefore can avoid the overheat of the human body surface which is directly contacted to the applicator. The measurement of the electric field distribution from the applicator and the heating experiment at 430 MHz show the availability of the applicator.

### I. INTRODUCTION

Recent EM energy application for medical diagnosis and therapy, such as temperature measurement of the human body and hyperthermia treatment of cancer, demands the reliable and easy coupling method of the EM energy to the human body[1]-[3]. The usual method for such energy coupling method basically applies rectangular waveguide applicators. Such applicators are usually heavy in weight, large in size and fixed form. Therefore, these defects sometimes makes it difficult to apply clinical treatment. Using microstrip may solve these problems, because it is possible to design small in size, flexible and light in weight. The flexibility has a merit that the applicator fits on the complex part of human body.

In this paper, light, thin and flexible applicator to radiate EM energy to the human body is designed and the availability of heating is examined by its electric field distribution and heating experiment.

### II. DESIGN OF MICROSTRIP PATCH APPLICATOR

A structure of microstrip patch applicator is shown in Figs. 1 (a), (b) and (c). The patch and the ground plane on the silicone rubber are connected to a coaxial cable through the APC-7 type connector. The connector is firmly fixed by acrylic resin stick placed on the edge of the ground plane. The thickness of the microstrip patch, that is the length between the ground plane and the patch, is sustained by the 5 mm width silicone rubber shown in Fig. 1 (b). Water is flowed in the space between the patch and the ground plane. The water acts as the dielectric and also acts to avoid the surface overheat of the medium directly contacted to the microstrip patch applicator. The flexibility of the applicator is shown in Fig. 2. Here,  $\epsilon$  is the relative dielectric constant in the applicator and can be given by

$$\log \epsilon = V_1 \log \epsilon_1 + V_2 \log \epsilon_2 \quad (1)$$

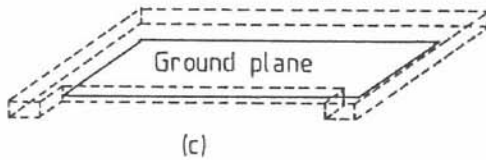
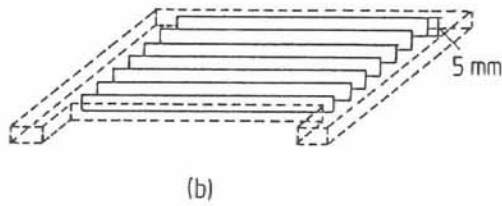
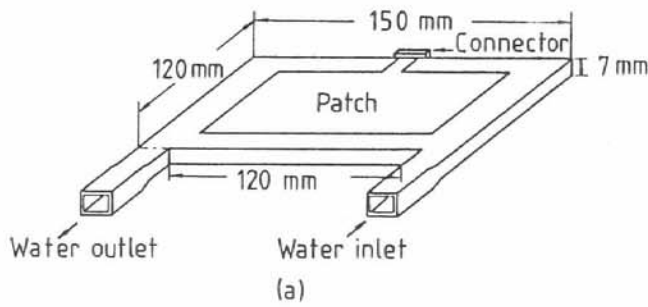

Fig. 1. Flexible microstrip patch applicator.

- (a) Schematic view.
- (b) Patch and ground plane separator.
- (c) Ground plane.



Fig. 2. Flexibility of the microstrip applicator.

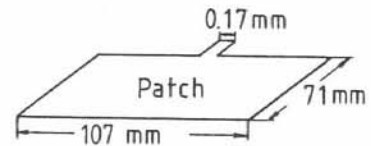
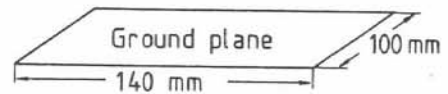

Fig. 3. Dimension of the microstrip applicator.

where  $V_1$  and  $V_2$  are the volume ratio of water and silicone,  $\epsilon_1$  and  $\epsilon_2$  are the relative dielectric constant of water and silicone, respectively. The length of patch is given by

$$L = \frac{c}{2f\sqrt{\epsilon}} - 2\Delta l \quad (2)$$

where  $L$  is the length of patch,  $f$  is the frequency. The width of patch is given by

$$W = \frac{\lambda}{2\sqrt{\frac{\epsilon + \epsilon_h}{2}}} \quad (3)$$

where  $\epsilon_h$  is the dielectric constant of the heating medium and  $\lambda$  is the wavelength.

The applying frequency is 430 MHz. The actual dimension of the ground plane and the patch is shown in Fig. 3.

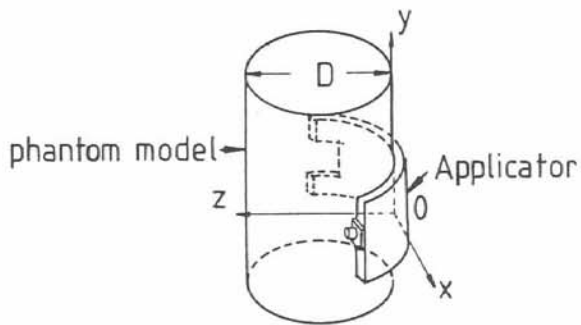

Fig. 4. Experimental set-up with axis.

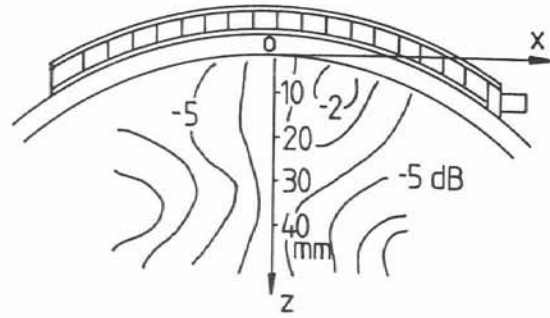

Fig. 5. Electric field distribution in the human tissue model of 0.2 % NaCl solution.

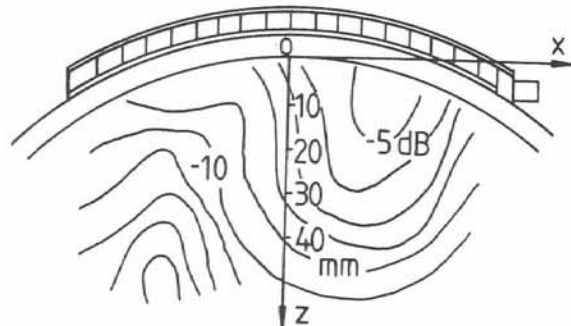

Fig. 6. Electric field distribution in the human tissue model of 0.4 % NaCl solution.

### III. EXPERIMENTAL RESULTS

#### A. Electric Field Distribution

The experimental set-up is shown in Fig. 4. Electric field was measured in the lossy liquid medium. Results of electric field distribution in the 0.2 % NaCl solution as a phantom model of human tissue is shown in Fig. 5. From Fig. 5, it can be seen that the maximum field is generated close to the feed because of the high attenuation of the medium. The electric field can penetrate well along the z axis.

The results of electric field distribution in the 0.4 % NaCl solution as a phantom model of human tissue is shown in Fig. 6. Figure 6 also shows the the maximum field generated close to the feed by the high attenuation of the medium. From these results, the depth of -3dB from the maximum electric field on the aperture is around 40 mm, therefore the depth of the effective heating can be estimated to reached around 40 mm.

#### B. Temperature Distribution

The heating experiment was performed using cylindrical shaped phantom modeling material of human tissues. Two types of the model were prepared. One was 150 mm in diameter and the other was 200 mm in diameter. Figure 7 shows the temperature elevation in the phantom modeling material of the human tissue which is 150 mm in diameter. The result shows that the the depth of the effective heating (i.e.  $(T_{\max} - T_{\min})/2$ ) reached to 40 mm, and the width of it reached to 50 mm. The result of heating of the simulated human model which is 200 mm in diameter shows in Fig. 8. The result also indicates almost the same heating availability.

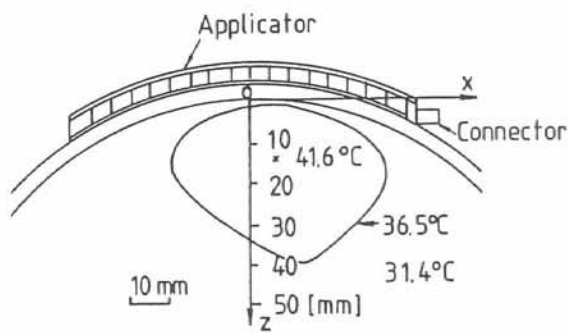

Fig. 7. Temperature distribution in the simulated human model (D = 150 mm).

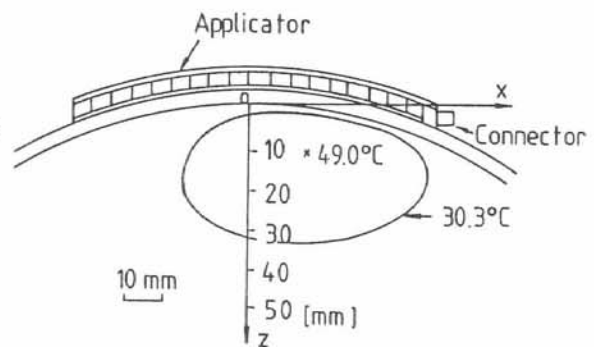
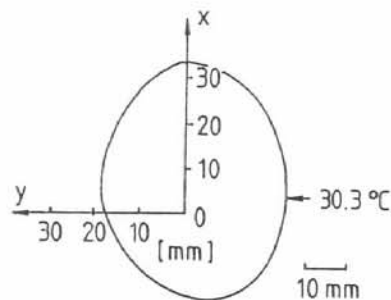
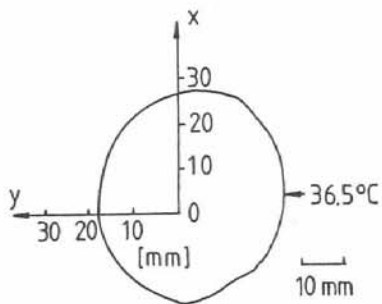

Fig. 8. Temperature distribution in the simulated human model (D = 200 mm).



#### IV. CONCLUSIONS

A small, light and flexible applicator has been designed. The applicator can fit on the complex shaped human body and can avoid the overheat of the human body surface which is directly contacted to the applicator by the cooling water flowed inside the applicator. The applicator of which total size 150 mm x 120 mm and thickness 7 mm operates at 430 MHz. The measurement of the electric field distribution from the applicator and the heating experiment shows the effective heating width of 50 mm and the effective heating depth of 40 mm can be realized. The measurement of the electric field distribution from the applicator and the heating experiment at 430 MHz show the availability of the applicator to the human tissue heating such as hyperthermia application.

#### REFERENCES

- [1] Y. Nikawa and F. Okada, "Temperature Measurement Technique Using Reflection Method for Application in Electromagnetic Hyperthermia," Proceedings of the Eighth Annual Conference of IEEE Engineering in Medicine and Biology Society, pp.1418-1421, 1986.
- [2] Y. Nikawa, T. Katsumata, M. Kikuchi, S. Mori, "An Electric Field Converging Applicator with Heating Pattern Controller for Microwave hyperthermia," IEEE Trans. on Microwave Theory Tech., vol. MTT-34, no. 5, pp.631-635, 1986.
- [3] J.R. James, C.M. Hall, G. Audrasic, "Angled Dual Compact Hyperthermic Applicators," IEE Proc., vol. 134, Pt. H, no.3, pp. 315-320, 1987.