

## DESIGN OF A LARGE DEPLOYABLE ANETENNA FOR THE SPACE VLBI SATELITTE

Hiromasa NAKAGURO, Tatsuhiro NOGUCHI, Kunito OHKUBO, Osami ISHIDA  
Mitsubishi Electric Corporation, Kamakura Works  
325 Kamimachiya, Kamakura, Kanagawa, Japan  
Tadashi TAKANO, Koryo MIURA  
Institute of Space and Astoronautical Science  
3-1-1 Yoshinodai, Sagamihara, Kanagawa, Japan

### 1. INTRODUCTION

Institute of Space and Astronautical Science (ISAS) has been planning to launch a new space astronomy satellite "MUSES-B" in 1995. The satellite will be used with ground-based radio telescopes to create a VLBI (Very Long Baseline Interferometry) system to obtain high-resolution images of galaxies at 22 GHz, 5 GHz and 1.6 GHz. A 10 m diameter radio telescope antenna will be used, and will be deployed in orbit. This paper describes the study results of the precision large deployable antenna reflector and multi-frequency feed for the "MUSES-B".

### 2. ANTENNA CONFIGURATION

Figure 1 shows the detailed structure of the antenna.<sup>(1)(2)</sup> The antenna consists of a central support structure, 6 extensible masts, a main reflector formed of cable and mesh assembly, the subreflector and its supporting-column, and the primary radiator with multifrequency feeding. The masts extend from the folded-in status around the central structure and pull out the cable and mesh assembly. At final stage of deployment, the subreflector support is extended along the antenna axis.

The surface accuracy design goal is less than 0.5mm r.m.s, and the overall weight is less than 226 Kg. As the tension truss reflector<sup>(1)</sup> utilizes thousands of cables, some considerations are made to prevent the tangling. The joint devices of cable and the holders of folded cables are contrived. The cables and mesh will be packed into several parts, and will be deployed sequentially one part after another to avoid contacts and interference between the parts.

### 3. REFLECTOR DESIGN

The displaced axis Cassegrain antenna<sup>(3)</sup> was selected for the radio telescope antenna from the point of view to maximize the gain by reducing the loss due to subreflector blockage. The antenna design parameters are shown in Figure 3. These design parameters were preferentially optimized for 22 GHz band that is the main observation frequency, and selected in consideration of the mechanical constraints such as allowable fairing volume and subreflector extension capability. The F/D ratio and Db indicated in Figure 2 are determined by the mechanical constraints and the minimum blocking condition, respectively. Ds is settled by the allowable fairing volume considering the limitation of the subreflector support extension. The antenna efficiency can be maximized by selecting Dh and Rh for the given Ds.

Mesh reflecting surface with small openings is especially needed for 22 GHz band. The fine tricot mesh of the gold plated molibdenum wire of about 1 mm openings is developed for this purpose. The measured transmission

coefficient of mesh was less than -19 dB at 22 GHz band.

Figure 3 shows the calculated radiation pattern for 22 GHz band, and Table 1 shows the antenna gain budget for the required frequency bands.

### 3. FEED DESIGN

The antenna is operated in three frequency bands of 22 GHz, 5 GHz and 1.6 GHz, and operated in left-handed circular polarization. The feed of primary radiator is designed to separate the above three frequency bands by utilizing the frequency cutoff characteristics of tapered circular waveguides. The multifrequency feeding system consists of a conical horn, 1.6 GHz feeding assembly, 5 GHz feeding assembly and 22 GHz feeding assembly as shown in Figure 4.

The configuration of the 1.6 GHz feeding assembly is shown in Figure 5. The feeding assembly consists of a TE<sub>11</sub> mode coupler, band rejection filters, coaxial/waveguide adaptors, and a power combining network. The TE<sub>11</sub> mode coupler provides four coupling holes located at 90 degree intervals around a waveguide axis. The band rejection filters are provided to reject the unnecessary frequency components coming into the 1.6 GHz port as shown in Figure 6. These filters form a series of resonant circuit. The coaxial/waveguide adaptor is utilized an H-plane loop coupling to make easy connection between coaxial/waveguide adaptor and power combining network. The power combining network shown in Figure 7 excites four branching waveguides by the desired amplitude and phase distribution. The coaxial waveguide transmission line is adopted for the power combining network to reduce the insertion loss.

The 5 GHz feeding assembly is designed based on the same concept applied for the 1.6 GHz feeding assembly. The 22 GHz feeding assembly consists of a polarizer and an OMT(Ortho-Mode Transducer). The polarizer with the capacitive posts is adopted from the viewpoints of mechanical compactness and high reliability. To improve axial ratio, the OMT absorbs the cross polarization components which would be generated by multiple reflections within feeding system.

The bread-board model of multifrequency feeding system, shown in Figure 8, has been manufactured and tested in order to verify the electrical design. The overall measured performance of the feeding system is shown in Table 2.

### 4. CONCLUSIONS

The design of the large deployable antenna reflector and multifrequency feeding system for the "MUSES-B" is performed. The bread-board model of multifrequency feeding system has been developed and tested in order to verify the electrical performance. From the results, it was confirmed that the feed design satisfies the target electrical performance.

### 5. REFERENCES

- 1)K.Miura et al, "Development of a Precision Large Deployable Antenna", Proceeding of 1989 International Symposium in Antenna and Propagation", 1B2-5.
- 2)K.Miura and Y.Miyazaki, "Concept of the Tension Truss Antenna", AIAA Journal, Vol.28, No.6, June, 1990.
- 3)W.Rotman et al, "Compact Dual Frequency Reflector Antenna for EHF Mobile Satellite Communication Terminals", IEEE, APS-20-4, 1984

Table 1 Antenna Gain Budget

Frequency Band	22GHz	5GHz	1.6GHz
Directive Gain	67.31	54.12	44.80
Spill Over Loss	-1.09	-1.84	-5.11
Surface Accuracy (*1)	-0.33	-0.02	-0.01
Mesh Reflection Loss	-0.06	-0.01	-0.01
Blocking (*2)	-0.30	-0.30	-0.30
Painted Surface (*3)	-0.08	-0.01	-0.01
Feed Loss	-0.50	-1.00	-0.80
Total	64.95	50.94	38.56

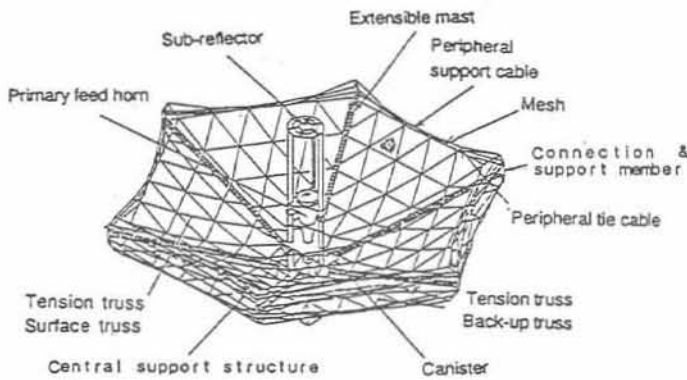

Figure 1 Antenna Configuration

Note) 1. unit in dB

2. due to sub-reflector extensible masts

3. sub-reflector (white paint)

4. Effects due to thermal distortion are not included.

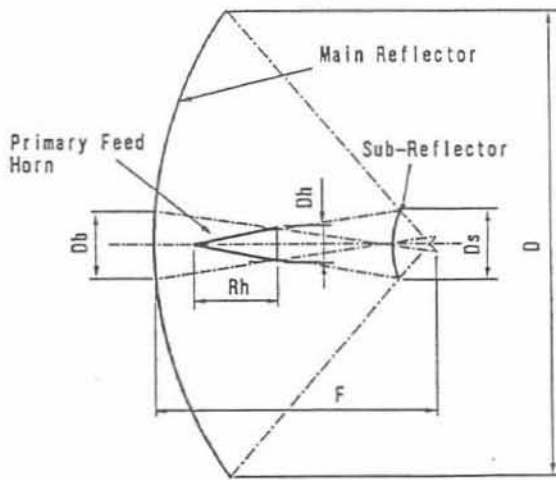

Figure 2 Antenna Design Parameters

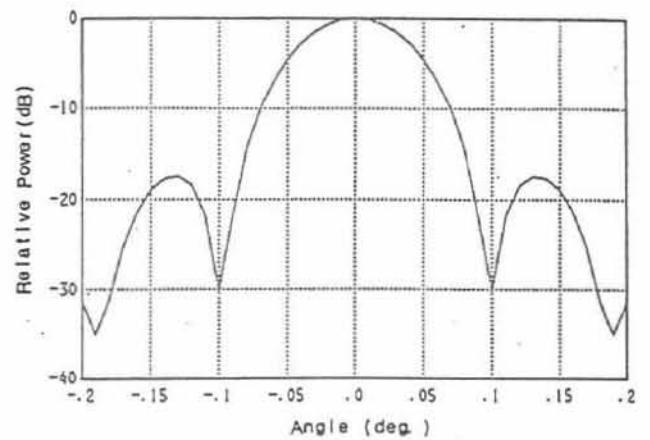

Figure 3 Calculated Radiation Pattern (for 22 GHz band)

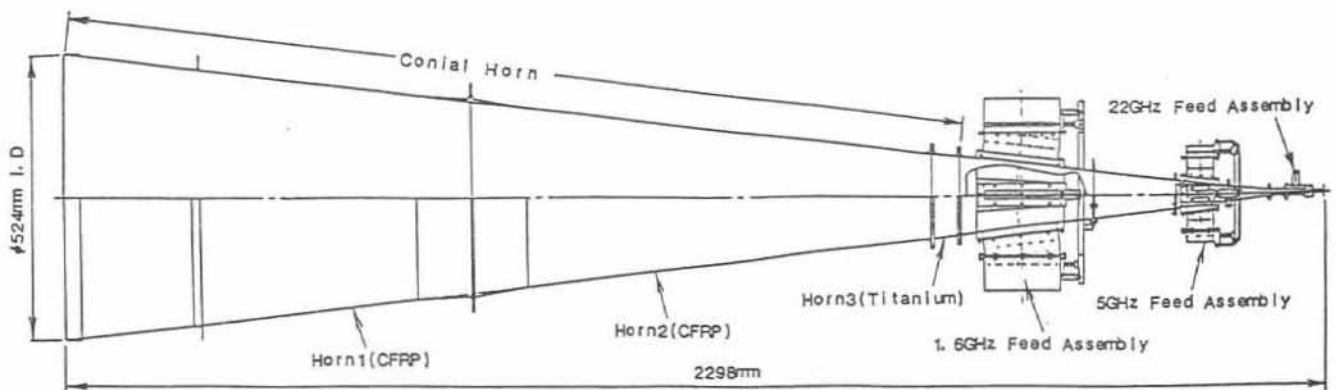

Figure 4 Primary Feed Horn

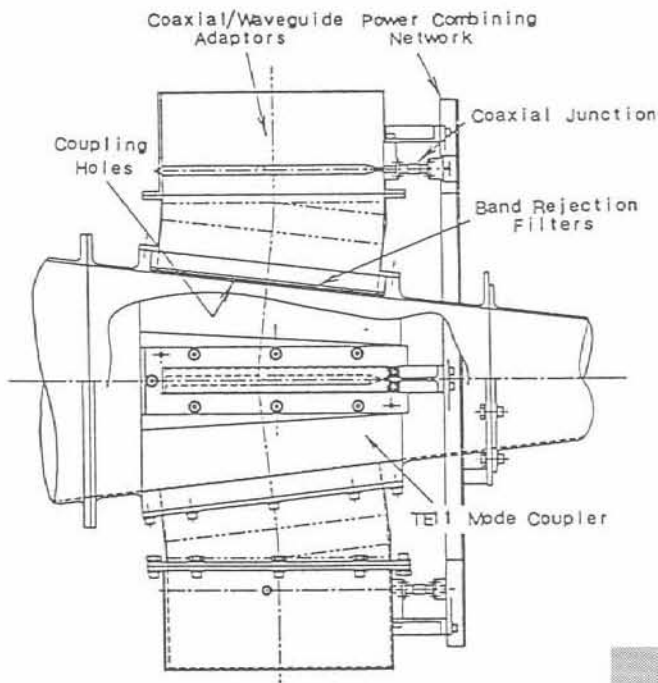

Figure 5 1.6GHz Feed Assembly

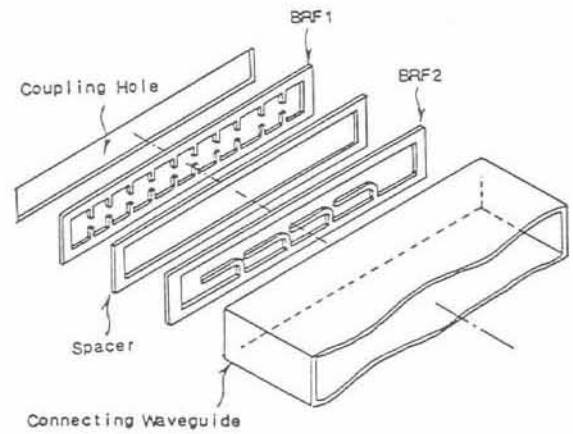

Figure 6 Band Rejection Filters

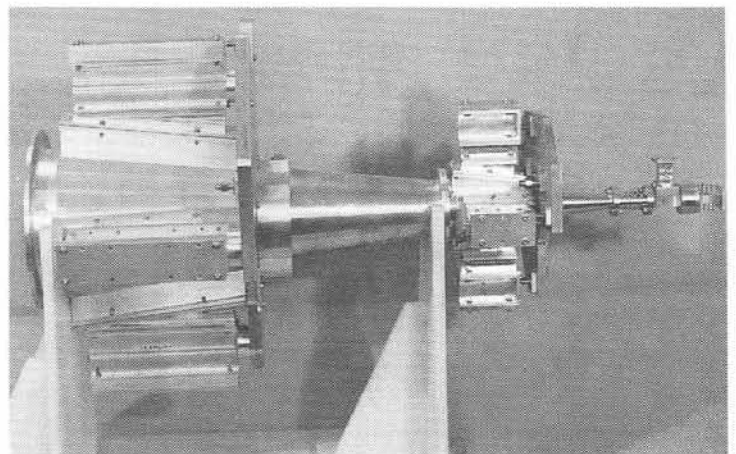

Figure 8 Bread-board model

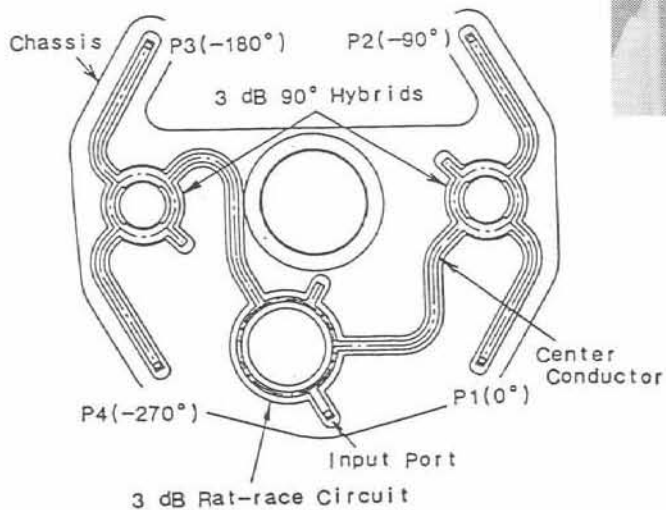

Figure 7 Power Combining Network

Table 2 Feed measured Performance

Frequency Band	22GHz	5GHz	1.6GHz
Input Port VSWR	<1.08	<1.19	<1.18
Insertion Loss(dB)	<0.5	<0.6	<0.7
Axial Ratio(dB)	<0.6	<0.6	<0.5
Higher Order Mode Generation (dB)	N/A	<-25	<-25
Frequency Isolation (dB)	N/A	<-30	<-30