

RECONSTRUCTION OF A HIGH-CONTRAST AND LARGE  
PENETRABLE OBJECT IN TIME DOMAIN BY USING  
THE GENETIC ALGORITHM

Hong-Ki CHOI, Sang-Yong YANG, and Jung-Woong RA.

Department of Electrical Engineering

Korea Advanced Institute of Science and Technology

373-1, Kusong-dong, Yusong-gu, Taejon, 305-701, Korea

Phone +82-42-869-8014 Fax +82-42-869-3410 email : chk@mwlab4.kaist.ac.kr

**Abstract**

A high contrast ( $\epsilon_r=7$ ) and large ( $3\lambda_u \times 3\lambda_u$ ) penetrable object is reconstructed by using the genetic algorithm (GA) plus the Levenberg-Marquardt algorithm (LMA) and FDTD numerical method in time domain. This iterative method in time domain needs GA for the reconstruction of the high contrast object while LMA is limited to use for the low contrast object.

**1. Introduction**

Reconstruction of a large penetrable object is achievable more easily in time domain[1] than in the frequency domain[2]. Born iterative method[1] reconstructs two dielectric cylinders with its relative dielectric constant upto  $\epsilon_r = 2.0$  in  $6\lambda \times 6\lambda$  space domain, where  $\lambda$  is the free space wavelength of the highest frequency components of the time domain signal. Iterative method using the modified Newton algorithm[3] minimizes the cost function to find the original profile of the object if the object contrast is low, where the cost function is defined as the summation of the squared magnitude of the difference between the measured and calculated scattered fields from the assumed dielectric profiles. For high contrast objects, however, this steepest descent (SD) algorithm may not give the original profile because it converges to the value of the local minimum of the cost function[3]. A high contrast object is reconstructed by using the simulated annealing(SA) algorithm[4] and the hybrid algorithm combining SA and SD algorithm[5] in the frequency domain. The maximum size is, however, limited by  $1.25\lambda \times 1.25\lambda$  due to its heavy load of computing time for the calculation of the scattered fields. Finite difference time domain (FDTD) method is the fast and accurate numerical technique dealing with a large scatterer of any profile[6]. It is shown here that squared dielectric cylinder of  $3\lambda_u \times 3\lambda_u$  size with its relative dielectric constant  $\epsilon_r = 7$  is reconstructed by using the FDTD and the hybrid algorithm combining the genetic algorithm with a steepest descent algorithm, where  $\lambda_u$  is the free space wavelength of the frequency component corresponding to the half spectral magnitude of the incident pulse signal.

## 2. Formulation

Gaussian pulse in the time domain is assumed as a transmitting signal. Transmitters are assumed to be located in the far zone of the scattering object. For the convenience of calculation, receivers detecting scattered fields are assumed to be very close to the scattering object, as shown in fig.1. As an absorbing boundary condition for the FDTD calculation, perfectly matched layer(PML)[7] is adopted to save the computation time. Four incident pulsed plane waves from  $\varphi = 0^\circ, 90^\circ, 180^\circ,$  and  $270^\circ$  are used and 8 receiving points are chosen. Received transient signals of each receiver are sampled by an equal time interval with its total number of samples  $M$ .

One may then define cost function  $f$  as the squared sum of error functions

$$f = \sum_{t=1}^4 \sum_{r=1}^8 \sum_{s=1}^M |F(t, r, s; \varepsilon_n^k)|^2, \quad (1)$$

where

$$F(t, r, s; \varepsilon_n^k) = U_M(t, r, s) - U_C(t, r, s; \varepsilon_n^k), \quad (2)$$

and  $U_M(t, r, s)$  is the  $s$ -th time-sample of the measured transient scattered field at  $r$ -th receiver from  $t$ -th transmitter, and  $U_C(t, r, s; \varepsilon_n^k)$  is the corresponding calculated scattered field for the  $k$ -th iteration of a set of profiles  $\{\varepsilon_n^k\}$ , where  $\varepsilon_n$  is the relative dielectric constants of the  $n$ -th population. FDTD calculates each  $U_C(t, r, s; \varepsilon_n^k)$  in eq.(2) and the Genetic algorithm(GA) finds the global minimum of the cost function  $f$  to reconstruct the original object profiles.

Gaussian pulse in time domain may be transformed into frequency domain with gaussian distribution as

$$\int_{-\infty}^{\infty} e^{-(t-t_0)^2/W^2} e^{j2\pi ft} dt = W e^{j2\pi ft_0} \sqrt{\pi} e^{-\pi^2 W^2 f^2} \quad (3)$$

where  $t_0$  is the time giving maximum value of amplitude of the pulse and  $W$  is a point where the pulse amplitude drops to  $1/e$ . One may take the effective pulse width, or time resolution,  $\Delta t$  of the gaussian pulse from two points where its magnitude drops to  $1/e$ , i.e.  $\Delta t = 2W$ , as shown in Fig.2(a). Now the signal bandwidth  $\Delta f$  corresponding to this time resolution  $\Delta t = 2W$  may be defined from the relation  $\Delta t \cdot \Delta f \sim 1$ , or  $\Delta f = 1 / 2W$ , which gives the upper frequency limit,  $f_u$ , of the signal as

$$f_u = \frac{1}{4W} \quad (4)$$

This frequency corresponds to the frequency where the spectral amplitude drops to 0.54 of its maximum value as shown in fig.2(b). In the following numerical example of reconstruction, the object size is expressed in terms of a free space wavelength  $\lambda_u$  corresponding to  $f_u$ . This choice of larger spectral amplitude, compared with the conventional choice of  $f_{max}$  for FDTD forward scattering problem where the spectral amplitude drops to 0.03, is preferable for the inverse scattering purpose, especially in the case when the measured field is contaminated by noise, since  $f_u$  maintains high signal to noise (S/N) ratio.

### 3. Numerical Results and Conclusions

The dielectric profile of a low contrast object is reconstructed by using the Levenberg-Marquardt Algorithm (LMA). The target is assumed to be a homogeneous square cylinder of its size  $1 \lambda_u \times 1 \lambda_u$ , and divided by  $0.25 \lambda_u$  square-cell unknowns, total number of  $4 \times 4 = 16$ . LMA reconstructs this object upto its relative dielectric constant  $\epsilon_r = 2.6$ , and fails to reconstruct for higher values than  $\epsilon_r = 2.6$  which corresponds to the Born criterion of broadband frequency[8]. One may show from the cost function diagram that initial profile of  $\epsilon_r = 1.0$  reaches to its nearest local minimum and does not find the global minimum with LMA. It is interesting to compare this time domain reconstruction with frequency domain reconstruction of the same sized object upto  $\epsilon_r = 1.7$  by using single frequency signal[3], which meets the validity criterion of single frequency Born inversion[9].

Higher contrast object may be reconstructed by using the Genetic algorithm(GA). A homogeneous square cylinder of its size  $3 \lambda_u \times 3 \lambda_u$  with relative dielectric constant  $\epsilon_r = 7.0$  is reconstructed in Fig.3 by using the hybrid algorithm combining LMA and GA. The object is discretized into  $12 \times 12 = 144$  unknowns and calculated fields are obtained from 8 receiving points with 4 transmitting pulsed plane wave incidences and a total of 120 time-samples of the scattered fields. Sampling time interval is chosen such that 2 time-samples for 1 cycle of the frequency  $f_u$  is satisfied, which meets the Nyquist sampling criterion for that frequency. 10 % gaussian random noise is added to the measured field. 144 unknowns are obtained, with its root mean square error of reconstruction 5.2%, by using 20 populations and about 40 generations of GA, which takes 37 minutes in cray2s CPU time. This target size of  $3 \lambda_u \times 3 \lambda_u$  corresponds to about  $6 \lambda \times 6 \lambda$  of the conventional definition of the highest frequency[1] whose spectral amplitude drops to 0.03 of its peak value.

### References

1. M. Moghaddam and W. C. Chew, 'Study on some practical issues in inversion with the Born Iterative using time-domain data,' *IEEE Trans.*, 1993, AP-41 pp. 177-184
2. K.-S. Lee, and J.-W. Ra, 'Angular spectral inversion for reconstruction of complex permittivity profiles,' *Microwave and Optical Tech. Letter*, 1992, pp.359-361
3. C.-S. Park, S.-K. Park, and J.-W. Ra 'Microwave imaging in angular spectral domain based on the improved Newton's procedure,' *Microwave and Optical Tech. Letter*, Jan. 1994, pp.28-31
4. L. Garnero, A.Franchois, J.-P. Pichot, and N. Joachimowicz, 'Microwave imaging : complex permittivity reconstruction by simulated annealing,' *IEEE Trans.* 1991, MTT-39, pp.1801-1807
5. J.-W. Ra and C.-S. Park, 'Moment method inversion of complex permittivity profiles by using propagating modes with multiple sources in the presence of noise,' Proc. URSI International Symp. on Electromagnetic theory, May. 1995, pp. 261-263
6. A. Taflove, 'Computational Electrodynamics,' Artech House, 1995.
7. J. P. Berenger, 'A perfectly matched layer for the absorption of electromagnetic waves,' *J. Comp. Phys.*, 1994, pp.28-43

8. J.-H. Kim, J.-W. Ra, 'Multifrequency microwave imaging of a lossy dielectric cylinder in a lossy medium, *Microwave and Optical Tech. Letter*, Sept. 1995, pp.26-31
9. M. Slaney, A. C. Kak, and L. E. Larsen, 'Limitation of imaging with first-order diffraction tomography,' *IEEE Trans.* 1984, MTT-32, pp.860-873

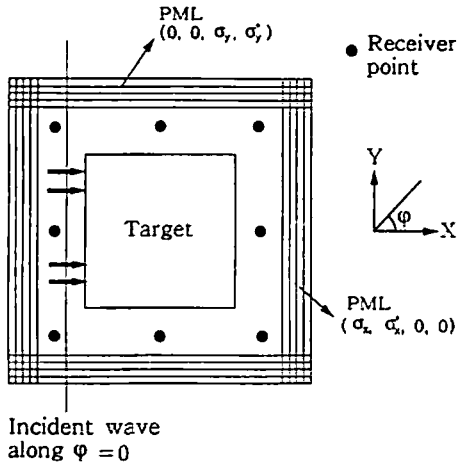

Fig.1 Geometry of a target, receivers, and incident waves

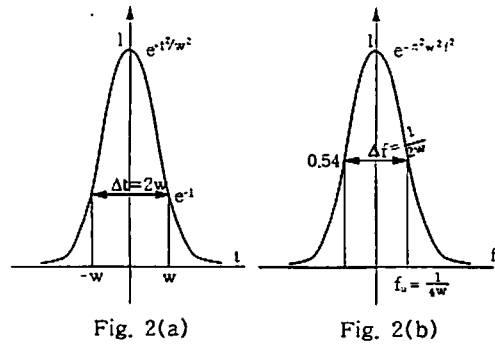

Fig.2 Gaussian pulse and its half amplitude bandwidth

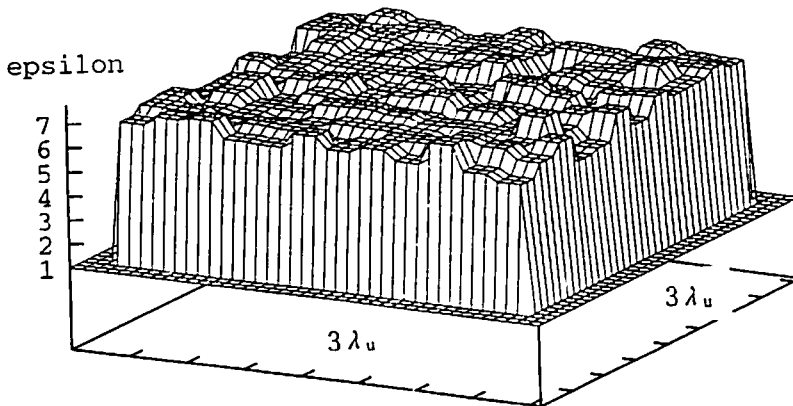

Fig.3 Reconstructed profile of the dielectric object with  $\epsilon_r = 7.0$  and its size,  $3 \lambda_u \times 3 \lambda_u$